

SUBARU

DESCRIPTION

Steering column assembly consists of a steering wheel incorporating a horn control, a combination turn signal, hazard warning, and headlight dimmer switch assembly, and an energy absorbing steering shaft. The steering column is connected to the steering gear through a universal joint coupling. The energy absorbing steering shaft is designed to collapse during a front end collision. An anti-theft locking mechanism is used to prevent steering shaft from turning when key is removed.

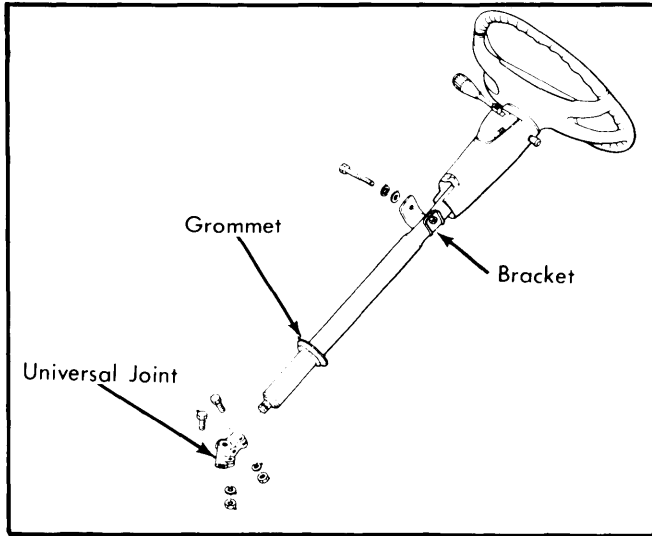

Fig. 1 Subaru Steering Column Assembly

REMOVAL & INSTALLATION

Removal – 1) Disconnect battery ground strap. Loosen the universal joint clamp bolt and separate shaft from joint.

2) Unplug all wiring connectors to the steering column switches. Remove steering shaft bolt from instrument panel and pull steering column from floorboard.

Installation – Insert column through floorboard into universal joint. Install column bolt into dashboard finger tight, then tighten universal joint clamp bolt in engine compartment. Connect all wiring and tighten dashboard bolt.

OVERHAUL

Disassembly – 1) Clamp steering column carefully in vise. Check back side of steering wheel for horn pad retaining bolt and remove if present. Remove pad by turning to left. Pull off steering wheel and remove column cover and hazard light knob.

2) Remove screws retaining bearing to steering column. Pull out shaft from the bottom of cover and remove snap ring, washer, "O" ring and bearing.

Inspection – 1) Universal joint should have no play in any direction. Replace if any play exists. Flex universal joint and check for binding. Replace if torque required to flex joint exceeds 0.43 ft. lbs. (0.06 mkg). Check plastic washer for damage, and serration for wear.

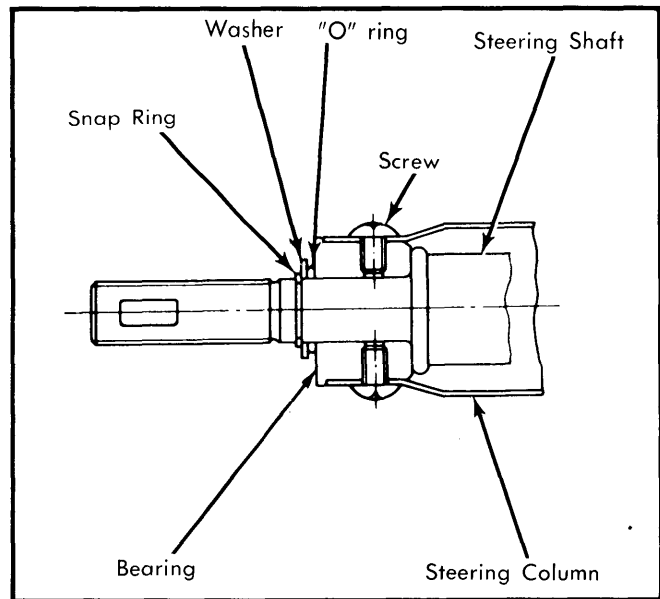

Fig. 2 View of Steering Shaft Components

2) Check steering shaft run-out and length. Run-out should be less than .02" (0.6 mm). Shaft for Subaru BRAT should be 32.84-32.92" (834.1-836.1 mm) in length. All others should measure 33.03-33.11 (839.1-841.1 mm). Replace shaft if damage is found. Check bearings for wear and replace if necessary.

Reassembly – To reassemble, reverse disassembly procedure and note the following: With steering wheel in place, check clearance between wheel and cover. If clearance exceeds .04-.12" (1.0-3.0 mm), loosen column cover screws and adjust cover.

TIGHTENING SPECIFICATIONS

Application	Ft. Lbs. (mkg)
Steering Wheel Nut	20-29 (2.8-4.0)
Column Bracket Bolt	12-15 (1.6-2.0)
Universal Joint Bolt	16-19 (2.2-2.6)