

BMW

320i
530i
633CSi
733i

DESCRIPTION

Steering column consists of a padded steering wheel with horn contact, turn signal/headlight dimmer switch, windshield wiper switch and an anti-theft steering column lock/ignition switch. Columns on 530i, 633CSi, and 733i are telescoping, while the 320i column is fixed in position. Column is connected to steering gear by universal joints and flexible coupling.

REMOVAL & INSTALLATION

STEERING COLUMN

Removal, 320i – 1) Disconnect battery ground cable. Remove lower half of steering column casing. Lift off pad from center of steering wheel and remove steering wheel.

2) Remove windshield wiper and turn signal switches at switch plate. Loosen set screw and pull out ignition switch.

3) Detach steering spindle at universal joint next to firewall in engine compartment. Loosen casing tube clamp at base of tube in driver's compartment. Drill or chisel off shear head bolts holding steering column to instrument panel. Remove steering column.

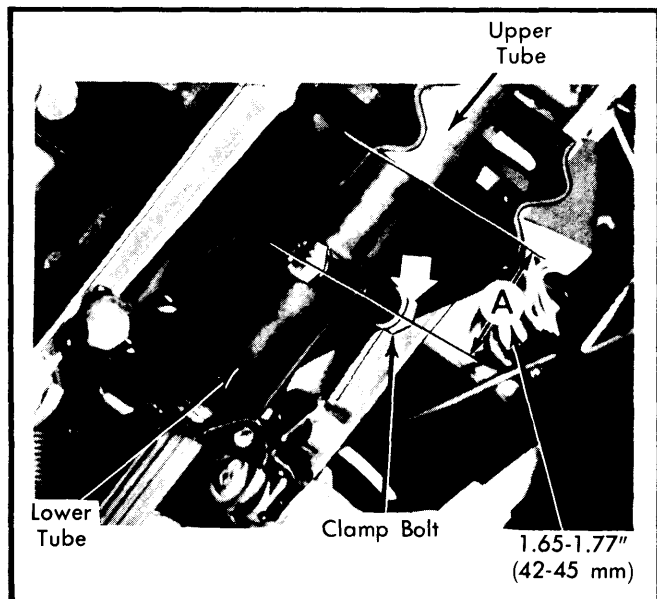

Fig. 1 Outer Tube and Clamp Bolt (530i & 633CSi)

NOTE – On 320i only, lower bearing may be replaced by driving shaft and bearing out from top. Remove snap ring, split ring and bearing. When reinstalling, stem of split ring must face bearing and snap ring must fit in locking groove.

Installation – To install, reverse removal procedure and note the following: Upper column casing and tube must be aligned prior to tightening. When installing turn signal switch, wheels must point straight ahead with switch in center position. With dog pointing to center of cancelling cam, adjust switch so that dog is about .12" (3 mm) from cancelling cam.

Removal, 530i & 633CSi – 1) Disconnect battery ground cable and remove steering wheel. Detach lower half of housing below column, then remove turn and wiper switches.

2) Remove spindle shaft holder at top of column. Loosen adjusting nut and mark position of upper and lower shafts. Carefully pry spindle shaft bearing from top of column and pull shaft out from above.

3) To remove upper outer tube, disconnect horn wire at carbon brush. Drill or chisel off switch plate shear screws and disconnect wiring harnesses. Loosen clamp bolt and support screws, then slide down lower outer tube. Lift up outer casing and pull out outer tube.

Installation – To install, reverse removal procedures noting the following: Prior to tightening clamp bolt, assure that distance from centerline of clamp bolt to end of upper outer tube is between 1.65" and 1.77" (42-45 mm). Align upper and lower spindle marks and tighten adjusting nut.

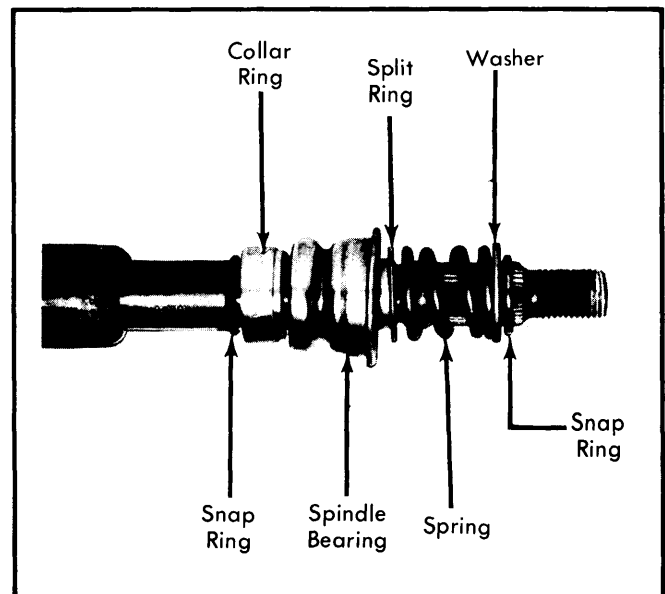

Fig. 2 Upper Column Spindle and Bearing (All Models Except 733i)

Steering Columns

BMW (Cont.)

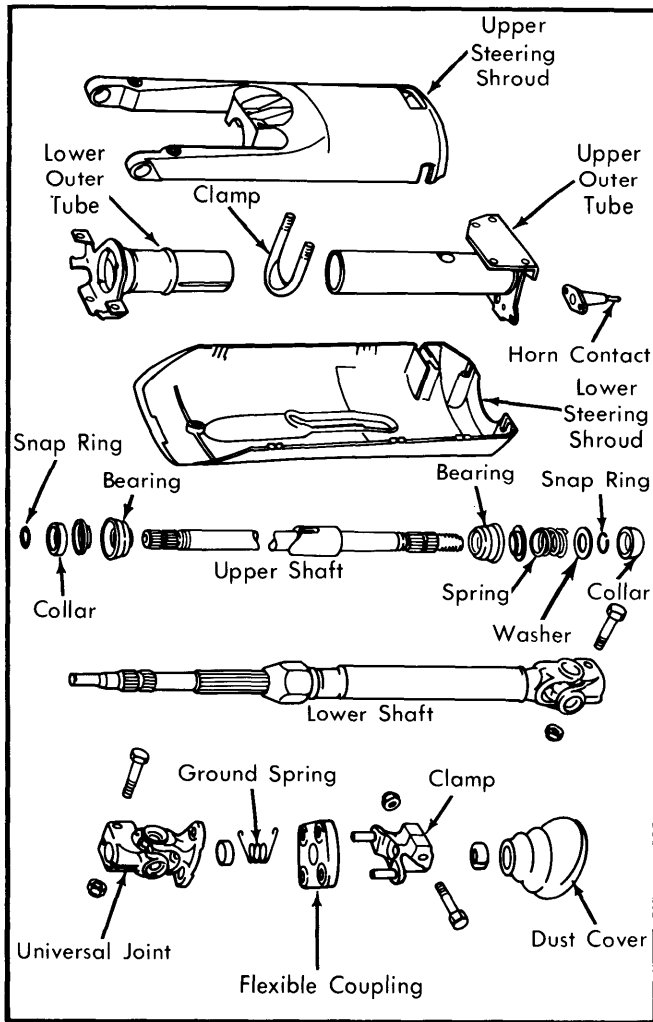

Fig. 3 Exploded View of Steering Column (733i)

Removal, 733i – 1) Disconnect ground lead at battery and remove steering wheel. Remove lower instrument panel cover and steering column housing. Disconnect switches and remove all wiring and ignition switch.

2) Remove clamp bolt and detach lower shaft. Remove 5 bolts holding column assembly to dash and pedal bracket. Remove upper shroud and shaft. Disconnect lower shaft from clamp in engine compartment and pull into passenger compartment.

3) Remove inner steering shaft by taking off collar, snap ring, washer, spring, and lock ring. Pry out upper bearing with screwdrivers. Pry out lower bearing and remove shaft. Remove snap ring, collar, ring and bearing.

Installation – To install, reverse removal procedure. Wheels must be in straight ahead position when shafts are connected. Ensure all washers and spacers are replaced. Ignition switch must be in "O" position when installed.

TIGHTENING SPECIFICATIONS

Application	Ft. Lbs. (mkg)
Steering Wheel Nut	62-69 (8.5-9.5)
Universal Joint-to-Spindle	18-20 (2.5-2.8)
Casing Tube Clamp Bolt	
320i	12-14 (1.7-1.9)
530i & 633CSi	16-17 (2.2-2.4)
Column-to-Housing	10 (1.5)
Column Bracket-to-Dashboard	16 (2.2)
Lower-to-Upper Shaft Bolt (733i only)	18 (2.5)