

VOLKSWAGEN TYPE 2

Type 2

DESCRIPTION

Independent torsion bar type rear suspension. Torsion bars mount in rear crossmember tube and anchor in center of tube by means of a splined hub. Outer ends of torsion bars mount into splined hubs integral with spring plates. Control arms are connected to spring plates. Control arms pivot in mounts connected to crossmember tube and connect at ends to rear wheel bearing housing. Hydraulic shock absorbers mount between control arms and bracket integral with chassis.

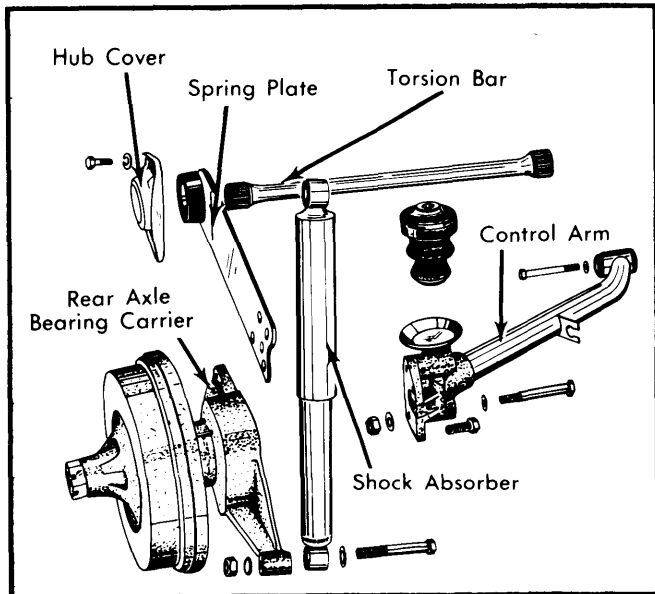

Fig. 1 Exploded View of Rear Suspension Assembly

ADJUSTMENT

WHEEL ALIGNMENT SPECIFICATIONS & PROCEDURES

See *Wheel Alignment Specifications and Procedures* in *WHEEL ALIGNMENT* Section.

REMOVAL & INSTALLATION

CONTROL ARMS

Removal — 1) Remove cotter pin and loosen rear axle hub nut. Raise vehicle and place safety stands under body. Remove

wheel and tire. Remove bolts from axle drive shaft at stub axle and separate axle drive shaft from stub axle. Disconnect shock absorbers from control arm.

2) Disconnect brake line and parking brake cable from backing plate. Mark position of spring plate in relation to control arm. Remove bolts securing spring plate to control arm. Remove control arm pivot bolt and remove control arm from vehicle.

Installation — 1) Install control arm in vehicle in an extended position, then tighten pivot bolt. Attach control arm to spring plate with index marks made during removal properly aligned; tighten bolts.

2) To install remaining components, reverse removal procedure and tighten all nuts and bolts. Check wheel alignment if new control arm has been installed.

SPRING PLATES & TORSION BARS

Removal — Disconnect spring plate from control arm as previously outlined. Remove bolts securing hub cover to crossmember and remove hub cover. Pry spring plate off lower stop (cast in housing) and pull spring plate out. Withdraw torsion bar. If broken torsion bar is being removed, opposite side torsion bar must be removed to drive out broken piece.

Installation — 1) Inspect torsion bar and spring plate for wear or distortion. Inspect rubber support bushings for wear or cracking. Grease torsion bar splines and install in vehicle. Torsion bars are marked left and right, install accordingly. Coat rubber bushings with talcum powder before installation.

2) Install spring plate on torsion bar in proper position. **NOTE** — See appropriate article in *WHEEL ALIGNMENT* Section for torsion bar setting procedure. Install rubber bushing and hub cover and secure hub cover with two bolts. Raise spring plate using spring compressor type tool (VW655/3), install remaining bolts and tighten. Reverse removal procedure for remaining components. Check wheel alignment.

TIGHTENING SPECIFICATIONS

Application	Ft. Lbs. (mkg)
Control Arm-to-Bearing Housing.....	94 (13.0)
Control Arm Pivot Bolt	43 (6.0)
Rear Axle Hub Nut.....	253 (35.0)
Shock Absorber Mounting Bolts	43 (6.0)
Torsion Bar Hub Cover.....	35 (4.5)
Axle Drive Shaft-to-Stub Axle	25 (3.5)