

Rear Suspension

TRIUMPH TR7

TR7

DESCRIPTION

Rear suspension system consists of a control arm (trailing arm), radius rod, and a stabilizer bar. A coil spring is mounted between body and control arm. Shock absorbers mount off axle housing at bottom and at top to body.

ADJUSTMENT

WHEEL ALIGNMENT SPECIFICATIONS & PROCEDURES

See *Wheel Alignment Specifications* in *WHEEL ALIGNMENT* Section.

REMOVAL & INSTALLATION

COIL SPRING & CONTROL ARM

Removal — Raise vehicle and place on safety stands. Remove wheel. Place jack under suspension control arm and compress spring ensuring vehicle does not come off stands. Remove two nuts and bolts mounting stabilizer bar to control arm. Remove nut and bolt securing rear end of suspension arm to axle bracket. Lower jack and remove spring and insulating rubbers. Detach suspension control arm front mounting and remove arm.

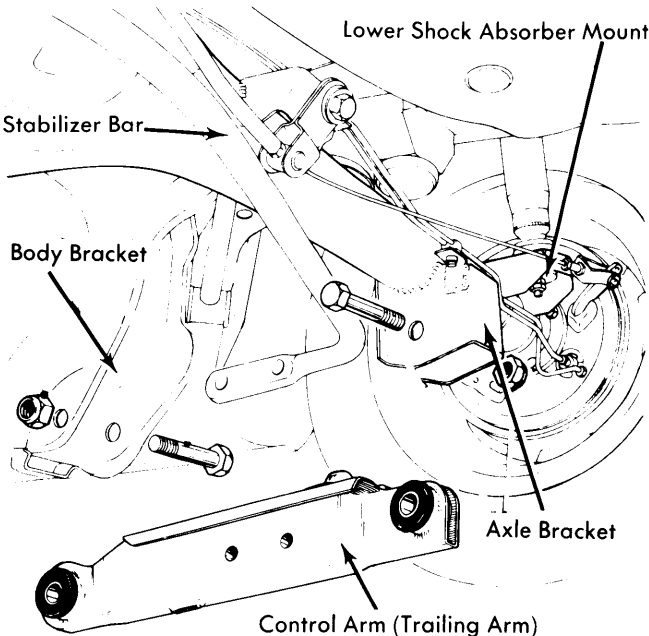

Fig. 1 Detailed View of Control Arm Removal

Installation — Insure spring insulators are in correctly, then fit spring. With jack positioned under control arm and front (body bracket end) of control arm installed, fit rear end of suspension control arm in axle bracket. Reconnect stabilizer bar to suspension arm and install wheel. Tighten suspension components with vehicle weight on ground.

SHOCK ABSORBERS

Removal — Jack up vehicle and place on safety stands; remove wheel. On right side, remove fuel filler assembly. On left side, remove upper access plate. On both sides, disconnect upper end of shock absorber and remove hardware. Disconnect and remove lower shock absorber mounting, then pull shock absorber from vehicle.

Installation — To install, reverse removal procedure and tighten nuts.

STABILIZER BAR

Removal & Installation — Raise vehicle and place on safety stands. Remove the four bolts mounting stabilizer bar to rear suspension arms. Remove stabilizer bar with shims, if equipped. To install, reverse removal procedure and ensure shims are refitted.

RADIUS ROD

Removal & Installation — Raise vehicle and place on safety stands. Disconnect radius rod from rear axle bracket and from bracket attached to body; then remove radius rod. If bushings are damaged, press out of rod and install new ones. To install, reverse removal procedure.

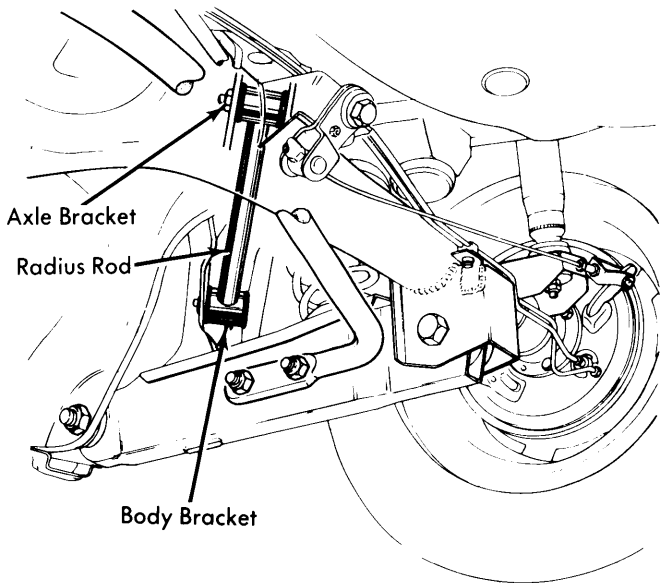

Fig. 2 Detailed View of Radius Rod Removal

TIGHTENING SPECIFICATIONS

Application	Ft. Lbs. (mg)
Stabilizer Bar-to-Control Arm	30-37 (4.2-5.1)
Shock Absorber-to-Control Arm.....	10-14 (1.4-1.9)
Shock Absorber-to-Body.....	10-14 (1.4-1.9)
Suspension Arm-to-Axle Bracket	38-48 (5.3-6.6)
Suspension Control Arm-to-Body Bracket...	38-48 (5.3-6.6)