

SUBARU

1600

DESCRIPTION

Rear suspension is independent, semitrailing arm type with torsion bars. Double action hydraulic shock absorbers are also employed.

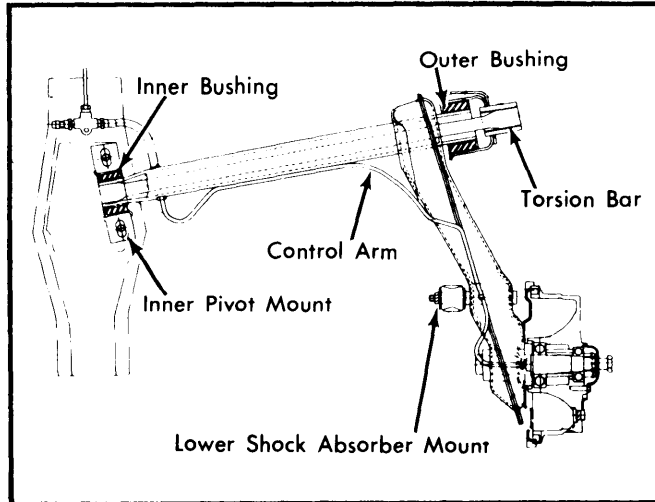

Fig. 1 Subaru Rear Suspension Components

ADJUSTMENT

WHEEL ALIGNMENT SPECIFICATIONS & PROCEDURES

See Wheel Alignment Specifications and Procedures in WHEEL ALIGNMENT Section.

REMOVAL & INSTALLATION

REAR SUSPENSION ASSEMBLY

NOTE — To repair or replace any rear suspension components, with the exception of shock absorbers, suspension assembly, for side being repaired, must be removed.

Removal — Raise rear of vehicle and support with safety stands. Remove rear wheels and disconnect brake line from flex line. Disconnect lower shock absorber mount. Remove bolts securing inner control arm pivot shaft mount to body. Loosen

lock bolt at outer bushing. Remove outer control arm pivot shaft mount bolts and remove suspension assembly for one side. This procedure applies to both sides of rear suspension.

Disassembly — With lock bolt removed, pull outer bracket from bushing and pull torsion bar from control arm. Remove outer bushing with a suitable puller (925210000). Inner bushing can be removed in same manner.

Reassembly — Press bushing onto control arm, making sure bushings are flush with ends of control arm. Apply grease to serrations on end of torsion bar. Torsion bars are marked "R" and "L", they should be installed accordingly. The angle between center line of bushing and control arm (see illustration), should be 6°.

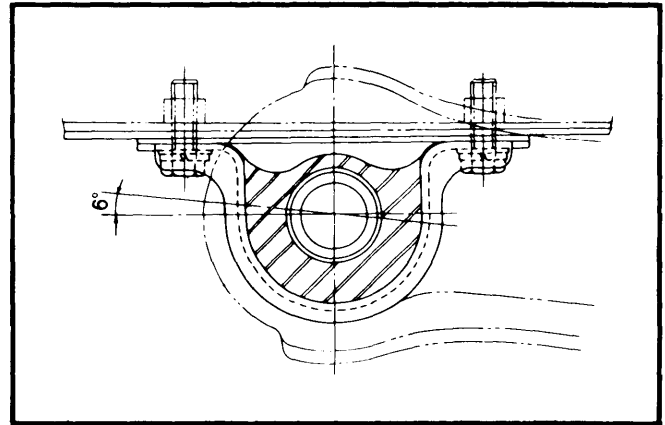

Fig. 2 Measuring Angle Between Centerline of Bushing and Control Arm

Installation — To install suspension assembly, reverse removal procedure. Tighten all bolts and nuts to specifications. Bleed hydraulic brake system and check wheel alignment.

TIGHTENING SPECIFICATIONS

Application	Ft. Lbs. (mkg)
Inner Pivot Mount Bolts	14-18 (1.9-2.5)
Outer Pivot Mount Bolts	43-65 (6.0-9.0)
Outer Pivot Bushing Lock Bolt.....	13-18 (1.8-2.5)