

VOLKSWAGEN TYPE 2

Type 2

REMOVAL & INSTALLATION

DESCRIPTION

Independent ball joint type suspension with torsion bars. Front axle beam consists of two horizontal tubes held together at ends by endplates welded to tubes. Torsion bars are mounted inside tubes and anchor in center. Torsion arms are connected to end of torsion bars and mount to steering knuckles by means of ball joints. Hydraulic shock absorbers are mounted between lower torsion arms at bottom and to axle beam endplates at top. A stabilizer bar is mounted to lower torsion arms. Complete front axle assembly is removable.

ADJUSTMENT

WHEEL ALIGNMENT SPECIFICATIONS & PROCEDURES

See *Wheel Alignment Specifications & Procedures* in *WHEEL ALIGNMENT* Section.

WHEEL BEARING ADJUSTMENT

See *Wheel Bearing Adjustment* in *WHEEL ALIGNMENT* Section.

BALL JOINT CHECKING

See *Ball Joint Checking* in *WHEEL ALIGNMENT* Section.

FRONT SUSPENSION ASSEMBLY

NOTE— Most front suspension repairs can be accomplished without removing entire suspension.

Removal — 1) Raise vehicle and place safety stands under body. Remove tires and wheels. Disconnect brake fluid flex lines at brackets. Plug openings. On vehicles equipped with brake servo, remove push rod and take out servo.

2) Disconnect speedometer at left steering knuckle. Remove cover plate under pedal assembly. Engage 1st or 3rd gear. Remove gearshift rod lever at coupling.

3) On manual transmission models, remove gearshift lever and front rod. On automatic transmission models, remove gearshift rod from lower selector lever. Disconnect clutch cable pedal. Separate parking brake cables at parking brake lever.

4) Separate drag link from pitman arm. Remove steering damper from axle tube bracket and swing damper out of way.

5) Place floor jack (and adaptor VW 610) under axle. Raise jack until contact is made. Remove 4 axle beam mounting bolts. Lower jack and guide assembly from vehicle.

Installation — Reverse removal procedure. Tighten nuts and bolts. Bleed brake system. Check front wheel alignment.

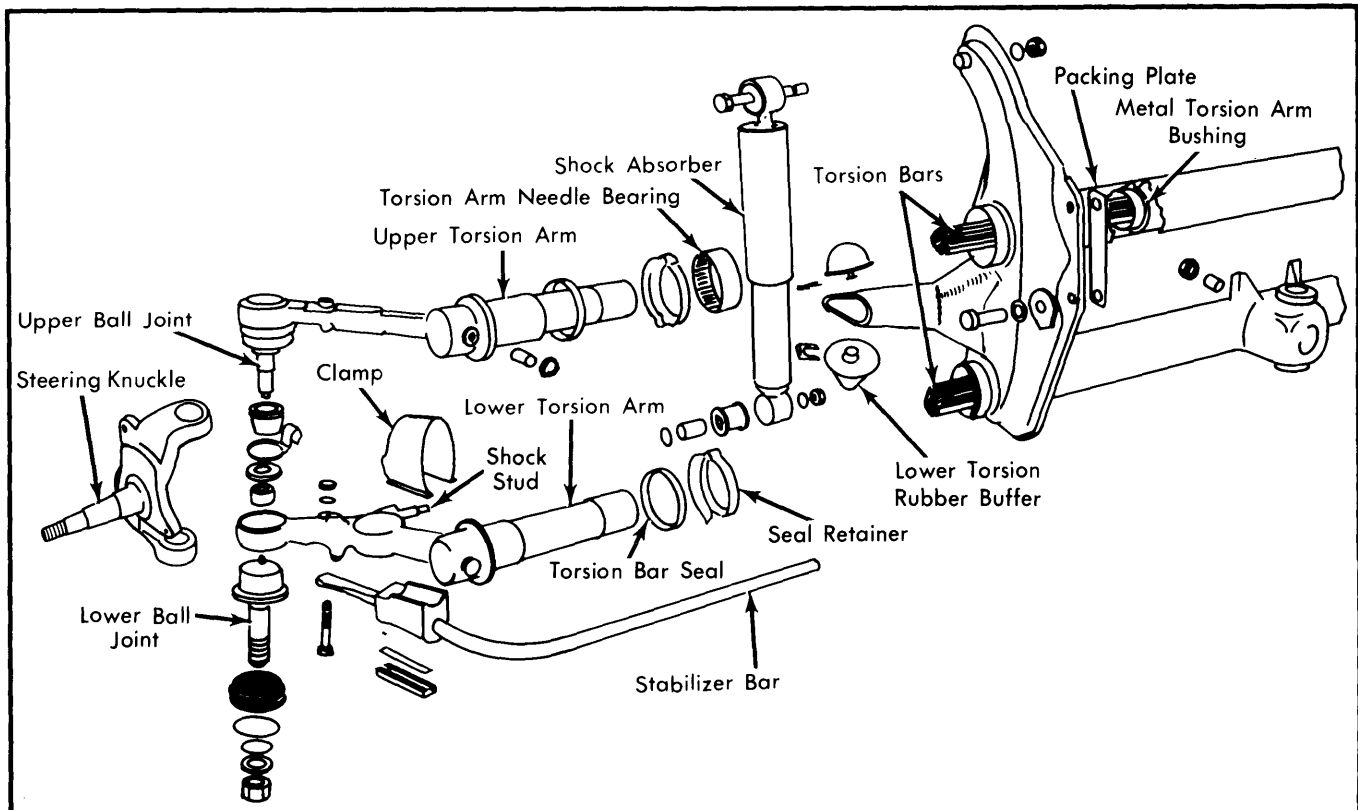

Fig. 1 Exploded View of Front Suspension Assembly

Front Suspension

VOLKSWAGEN TYPE 2 (Cont.)

STEERING KNUCKLE

Removal - 1) Raise vehicle and place safety stands under body. Remove wheel and tire. If left side knuckle is being removed, pull out speedometer cable. Disconnect brake caliper and support out of way. Remove cotter pin and castellated nut from tie rod end. Use a press type tool and separate tie rod from steering knuckle.

2) Remove splash shield from steering knuckle. Take off lower ball joint nut and press joint from knuckle. Remove upper ball joint nut, then with suitable wrench, turn camber eccentric adjusting bushing until joint is free from knuckle. See Fig 2.

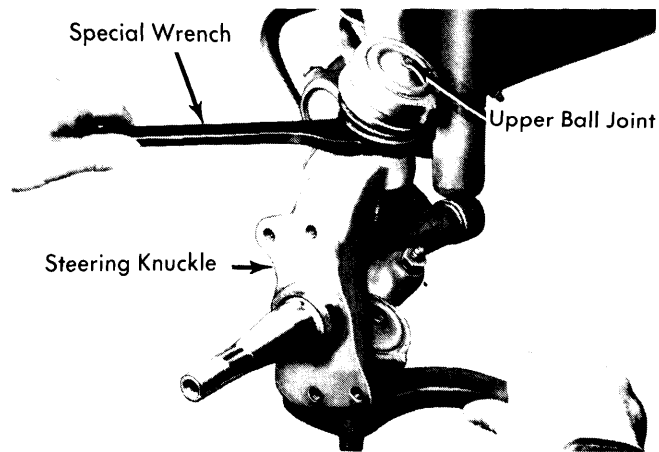

Fig. 2 Removing Upper Ball Joint from Steering Knuckle

Installation - 1) Inspect all components for wear or distortion. Loosely attach steering knuckle to lower torsion ball joint. Raise lower torsion arm until steering knuckle engages upper ball joint.

CAUTION - Position notch on camber adjusting bushing so it faces forward.

2) Install all new self locking nuts to ball joints. Insert cotter pin in tie rod stud. Install brake components. Adjust wheel bearings and check wheel alignment.

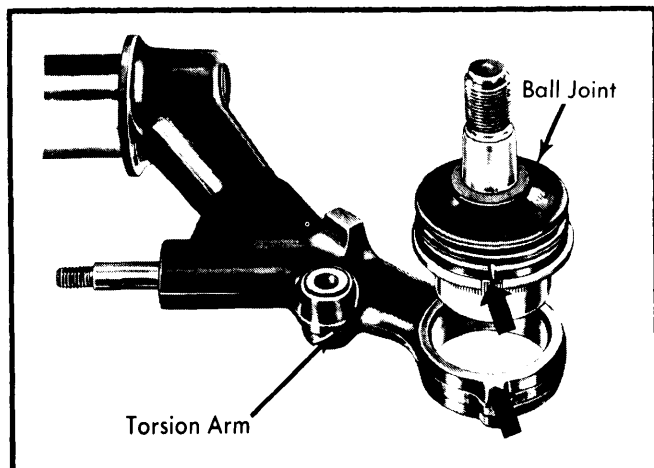

Fig. 3 Align Notch in Ball Joint with Boss on Torsion Arm

STABILIZER BAR

Removal - Knock retaining clip from clamp. Bend up clamp and remove plates. Remove nut from retaining bolt and remove bolt. Remove stabilizer bar from vehicle.

Installation - Inspect rubber components for wear or cracking. Inspect stabilizer bar for wear or distortion. Install stabilizer bar and retaining bolt and tighten nut to specification. Install clamp with cutout facing wheel. Press edges of clamp together with a pair of pliers and install clip. Make sure tongue edge of clip is facing axle beam. Lock clip by bending over tongue.

TORSION ARMS & BALL JOINTS

Removal - Raise vehicle and place safety stands under body. Remove wheel and tire. Remove steering knuckle and stabilizer bar as previously outlined. Back lock nuts from set screws and remove set screws. Pull torsion arms out of axle tubes. Press ball joints out of torsion arms.

Installation - Press ball joints into torsion arms. When pressing ball joints into control arms make sure that notches in shoulder of ball joint align with forged projections on torsion arm. Install a suitable peening tool (VW471) on press and peen ball joint 3 times with a pressure of 6 tons to insure ball joint is properly seated in torsion arm. Thoroughly grease pivot portion of torsion arm and install in axle tube. Reverse removal procedure for installation of remaining components. Tighten all bolts and nuts to specifications. Bleed brake system and check wheel alignment.

SHOCK ABSORBER MOUNTING STUD

Removal - Remove lower torsion arm as previously outlined. Drive dowel pin out and pull stud from torsion arm. If stud is broken, center punch in center of remaining piece and drill a .12" pilot hole in stud. Then drill remaining piece out with a .423" drill.

Installation - Replacement studs are oversized. Drill out hole with a .483" drill and ream to .4904-.4914" (12.45-12.8 mm). A press fit of .0004-.002" (.01-.05 mm) is required for proper fit. Press stud in arm until distance between shoulder of arm and end of stud is 1.77-1.79" (45.0-45.5 mm). Drill through dowel pin hole with .157-.161" (4.0-4.1 mm) drill and drive in dowel pin. Install torsion arm in vehicle as previously outlined.

SHOCK ABSORBER

Removal - Raise and suitably support vehicle. Remove tire and wheel. Remove upper mounting nut and bolt. Pull shock absorber top rearward and remove nut holding lower end of shock absorber on stud.

Installation - To install shock absorber, reverse removal procedure and note: With vehicle still raised, incline shock absorber 30° to rear while torquing nuts. This will prevent lower rubber bushing from twisting as suspension moves upward.

CAUTION - DO NOT incline shock absorber if vehicle weight is on ground.

VOLKSWAGEN TYPE 2 (Cont.)

TORSION BARS, AXLE BUSHINGS & BEARINGS

Removal - 1) Raise vehicle and place on safety stands. Remove both tires and wheels. Remove steering knuckle from both sides. Remove torsion arm from one end of torsion bars. If lower bar is being removed, remove shock absorber. If upper bar is being removed, remove gearshift rod at coupling and set to one side.

2) Loosen lock nut and remove screw from center of axle tube. Pull out torsion bar. Remove torsion arm from bar.

Bearing Assembly Replacement - 1) Use a slide hammer and remove bearing. Measure metal bushing. If diameter of bushing exceeds 1.71" (43.4 mm), use slide hammer with fingers or washer inserted behind bushing and pull out bushing.

CAUTION - DO NOT damage or pull out plastic sleeve in axle tube. Replacement sleeves are not available, axle tube must be replaced.

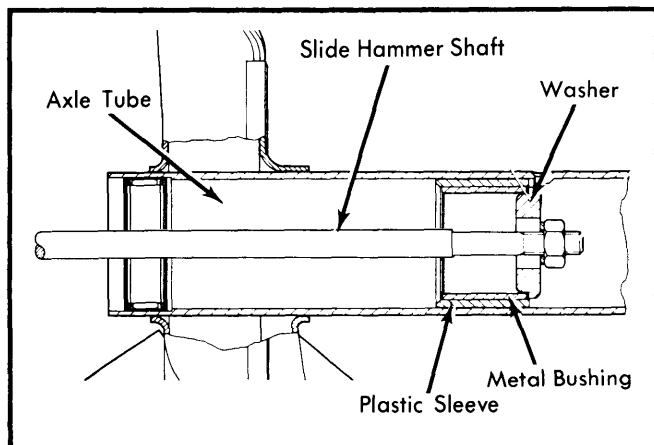

Fig. 4 Section View Showing Front Axle Tube

2) Clean off needle bearing seat. Measure inside diameter of bearing seat. If measurement is between 2.243-2.244" (56.97-56.99 mm), use standard bearings. If measurement is between 2.251-2.252" (57.17-57.19 mm), install oversize bearings. Oversize bearings are stamped with letter "U". Axle tubes that will not accept oversize bearing must be replaced.

3) Clean bearing and bushing seats. Insert bearing with hardened surface facing out. Drive bearing in using special drift VW 772 (or equivalent) until drift shoulder just meets outside edge of axle tube.

4) Use bearing as drift pilot and drive metal bushing into place. Fit new seal retainer to axle tube with lug in vertical position. Oversize seal retainers are available and can be identified by notch in lip. Fit new seals.

Installation - Reverse removal procedure and note: White stripe paint mark on end of torsion bar identifies left side bar.

TIGHTENING SPECIFICATIONS

Application	Ft. Lbs. (mkg)
Ball Joint Stud Nuts	72 (10.0)
Torsion Arm Set Screw	29 (4.0)
Torsion Arm Set Screw Lock Nut	29 (4.0)
Stabilizer Bar Retaining Nut	31 (4.3)
Shock Absorber	
Lower Mount Nut	18-25 (2.5-3.5)
Upper Mount Nut	36 (5.0)
Torsion Bar Set Screw	29 (4.0)
Torsion Bar Set Screw Lock Nut	29 (4.0)
Axle Assembly-to-Body	65-90 (9.0-12.5)
Tie Rod End Stud Nut	22 (3.0)