

DATSUN PICKUP

Pickup

DESCRIPTION

Independent type suspension with torsion bars. Upper and lower control arms pivot on brackets which are integral with chassis. A steering knuckle spindle support is mounted between upper and lower control arms. Wheel spindle pivots on steering knuckle spindle support. A strut bar is mounted between lower control arm and chassis. A torsion bar is mounted outboard to lower control arm by means of a torque arm and mounted inboard to chassis by means of an adjustable spring anchor. A hydraulic shock absorber is mounted between lower control arm and upper control arm mounting bracket. A stabilizer bar is optional and may be installed on some vehicles; it is mounted to front chassis members and connected at ends to lower control arms.

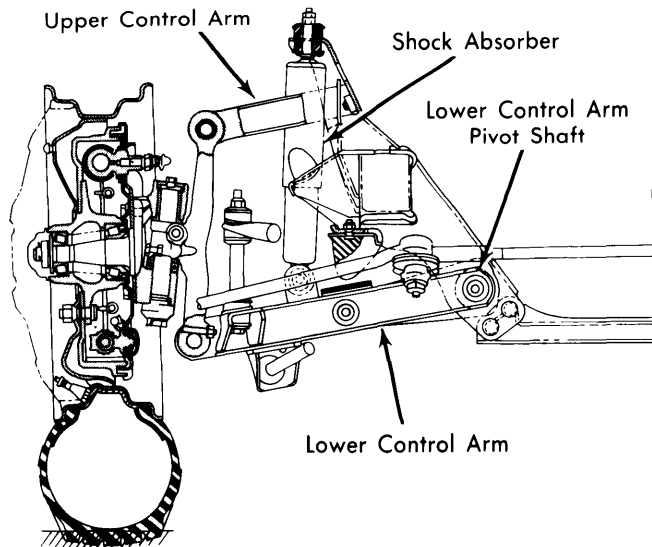

Fig. 1 Sectional View of Front Suspension Assembly

ADJUSTMENT

WHEEL ALIGNMENT SPECIFICATIONS & PROCEDURES

See Wheel Alignment Specifications & Procedures in WHEEL ALIGNMENT Section.

WHEEL BEARING ADJUSTMENT

See Wheel Bearing Adjustment in WHEEL ALIGNMENT Section.

BALL JOINT CHECKING

See Ball Joint Checking in WHEEL ALIGNMENT Section.

REMOVAL & INSTALLATION

SHOCK ABSORBER

Removal — Remove nut and slide out bolt retaining shock absorber to lower control arm. Remove upper shock absorber retaining nut and remove shock absorber from vehicle.

Installation — To install, reverse removal procedure and tighten all nuts and bolts.

STABILIZER BAR

Removal — Raise and support vehicle, then remove wheel and tire. Loosen nut at lower link side of stabilizer bar. Remove stabilizer bracket-to-frame bolt, then remove stabilizer from link bolt and remove from vehicle.

Installation — To install, reverse removal procedure and note the following: Tighten nut on link bolt enough to create a distance of 3.84" (97.6 mm) between top of lower control arm and center of stabilizer bar.

TORSION BAR

Removal — Raise and support vehicle and remove wheel and tire. Loosen nut securing spring anchor bolt. Remove dust cover at rear of torsion bar spring and remove snap ring. Remove anchor arm by pulling out rearward, then remove torsion bar.

Installation — To install, reverse removal procedure and note the following:

- 1) Coat serrated end of torsion bar with suitable grease and install it in torque arm. **NOTE** — Torsion bars are marked left and right on ends of bars. If both bars are removed at one time, make sure they are installed on their correct sides.
- 2) Install anchor arm and adjust to obtain dimension "A" as shown. After installing snap ring and dust cover, tighten adjusting nut until dimension "B" is obtained.

Application	Dimension "A"	Dimension "B"
7 Ft. Bed	.591-.984" (15-25 mm)	2.362-2.756" (60-70 mm)

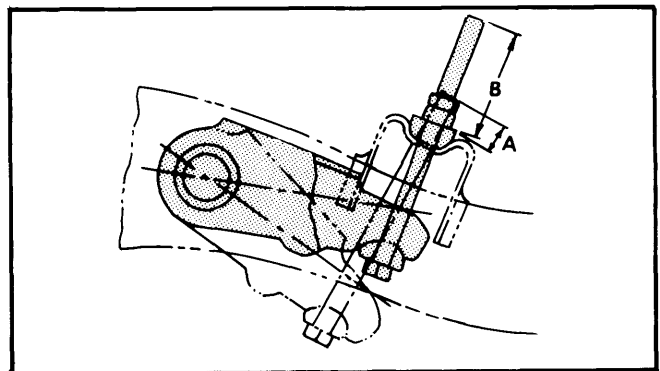

Fig. 2 View Showing Measuring Points for Installation of Anchor Pin

STRUT BAR

Removal — Raise and support vehicle, then remove wheel and tire. Remove retaining nuts, washers, and rubber grommets from both front and rear of strut bar. Remove mounting bracket bolts and remove strut bar from vehicle.

Installation — To install, reverse removal procedure while noting the following: Tighten nut so rubber bushings are each approximately .433" (11 mm) in width when compressed, then tighten lock nut to specifications.

DATSUN PICKUP (Cont.)

STEERING KNUCKLE SPINDLE

Removal — Raise and support vehicle, then remove wheel and tire. Disconnect brake hose from wheel cylinder and install a plug in line to prevent dirt from entering system. Remove brake drum. Remove dust cover, cotter pin, spindle nut, then remove brake hub with bearings and grease seal as an assembly. Remove backing plate and brake assembly from steering knuckle. Disconnect steering arm from spindle. Remove kingpin lock bolt. Drill a .413" (10.5 mm) diameter hole in plug at top of kingpin, thread the hole with a tap, then screw a bolt into hole and pull out plug. Drive out kingpin with a drift punch. Tap spindle using a soft faced hammer, and separate from spindle support while taking care not to drop thrust bearing.

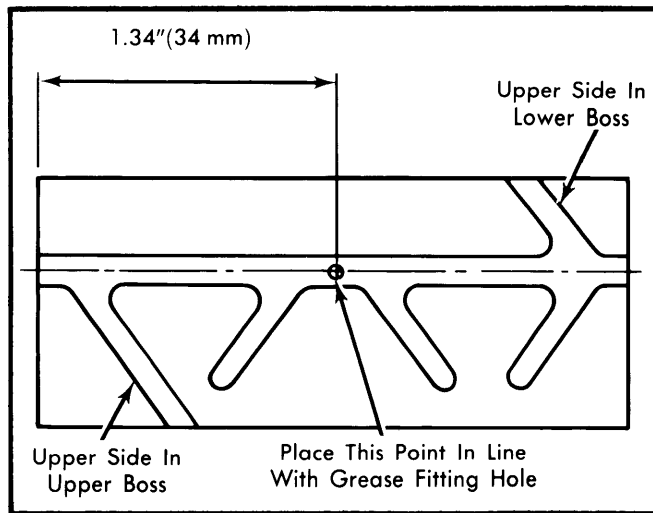

Fig. 3 View Showing Details of King Pin Bushing Installation

Inspection — Check kingpin and bushing for excessive wear, scoring, or damage. Check kingpin for diameter of .7866-.7874" (19.98-20.00 mm) and bushing for inside diameter of .7878-.7888" (20.01-20.04 mm). Clearance between bushing and kingpin should not exceed .0059" (.15 mm). If clearance or diameters are not within specifications, replace bushing and/or kingpin. To replace bushing, use a suitable bushing remover (ST35380000) to remove bushing and grease seal. Thoroughly clean bushing bore, then install bushing into spindle (see illustration). Ream bushing to specifications and install grease seal while taking care not to damage sealing lip.

Installation — Install "O" ring to lower end of spindle support. Install thrust bearing and spindle shim along with steering knuckle spindle to support. Clearance between spindle and spindle support should be .004" (.1 mm) or less, change shims as required to achieve this clearance. Thrust bearing must be installed with covered side upward. Install kingpin and lock bolt, making sure spindle moves smoothly. Install remaining components in reverse order of removal, then tighten all nuts and bolts.

UPPER CONTROL ARM & BUSHINGS

Removal — Raise and support vehicle, then remove wheel, tire, and brake drum. Disconnect brake hose from wheel cylinder and install a plug in line to prevent dirt from entering system. Remove dust cover, cotter pin, spindle nut, then remove brake hub with bearings and grease seal as an

assembly. Remove steering arm from spindle, torsion bar, stabilizer bar, shock absorber, and strut bar from vehicle. Remove upper control arm-to-spindle support bolt and separate arm from support. Remove control arm spindle-to-frame attaching bolts, then remove upper control arm taking care not to lose camber adjusting shims.

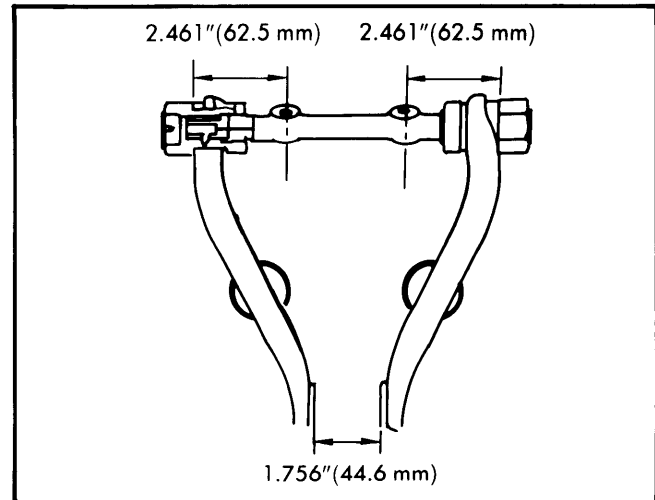

Fig. 4 Measurements for the Upper Control Arm Installation

Installation — To install, reverse removal procedure while noting the following: Install bushings in both sides of control arm and tighten to specifications. Install pivot shaft and screw into front and rear control arm links until measurements are as indicated in illustration. Tighten all nuts and bolts to specifications. Check front suspension alignment.

LOWER CONTROL ARM & BUSHINGS

Removal — 1) Raise and support vehicle, then remove wheel, tire, and brake drum. Disconnect brake hose from wheel cylinder and install a plug in line to prevent dirt from entering system.

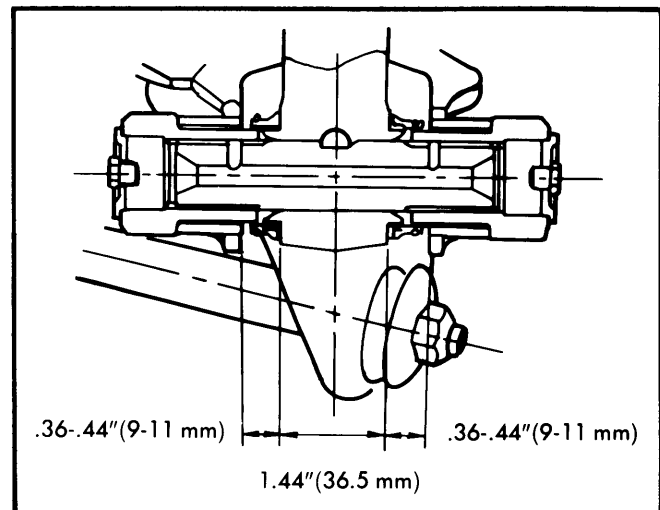

Fig. 5 Measurements for Lower Control Arm Installation

DATSUN PICKUP (Cont.)

2) Remove dust cover, cotter pin, spindle nut, then remove brake hub with bearings and grease seal as an assembly. Remove steering arm from spindle, torsion bar, stabilizer bar, shock absorber, and strut from vehicle.

3) Remove lower control arm bushings, then remove nut attaching cotter pin to spindle support. Remove cotter pin, then use a suitable drift to tap out lower control arm fulcrum pin and separate control arm from spindle support. Remove lower control arm-to-frame attaching bolt and nut, then remove control arm from vehicle.

Installation — To install, reverse removal procedure while noting the following: Install fulcrum pin while lining up notch of pin with spindle support to allow inserting of cotter pin. Install cotter pin and tighten lock nut. Coat bushing insides with grease and tighten bushings by hand temporarily. With dimensions as shown in illustration, tighten screw bushings to specifications. Tighten all nuts and bolts to specifications. Check front suspension alignment.

TIGHTENING SPECIFICATIONS	
Application	Ft. Lbs. (mkg)
Anchor Bolt Lock Nut	22-30(3.1-4.1)
Backing Plate-to-Spindle	30-36(4.2-5.0)
Brake Hose Connecting Nut	14-18(1.9-2.5)
Cotter Pin Lock Nut	5.8-8.0(.8-1.1)
Kingpin Lock Bolt	15-18(2.1-2.5)
Upper Control Arm Bushing	174-253(24-35)
Lower Control Arm Pivot	54-58(7.4-8.0)
Rubber Bumper Bolt	5.8-8.0(.8-1.1)
Shock Absorber Lower Bolt	23-30(3.1-4.1)
Shock Absorber Upper Nut	12-16(1.6-2.2)
Stabilizer Bar Bracket Bolts	12-16(1.6-2.2)
Steering Arm-to-Spindle	75-88(10.3-12.1)
Steering Knuckle Upper Pivot	28-38(3.9-5.3)
Strut Rod Bracket Bolts	12-16(1.6-2.2)
Strut Rod Lock Nut	12-16(1.6-2.2)
Torque Arm (Arm End)	20-27(2.7-3.7)
Torque Arm (Serration Boss)	13-19(1.8-2.6)
Lower Control Arm Bushing	181-231(25-32)
Upper Control Arm Pivot Bolt	51-65(7-9)