

SUBARU

All Models (Front) — Front wheel bearing is not adjustable. Tighten spindle nut to 174 ft. lbs.

4WD Station Wagon (Rear) — Rear wheel bearings are not adjustable. Tighten spindle lock nut to 145-181 ft. lbs.

All Other Models (Rear) — While rotating brake drum, snug down spindle nut to seat bearings. Back spindle nut off $\frac{1}{8}$ turn and bend down tab of locking washer to secure spindle nut. If adjustment is correct, a force of 6.1-8.7 INCH lbs. will be required to rotate wheel.

TOYOTA

Land Cruiser — Install claw washer and tighten front wheel adjusting nut with suitable tool (09607-60010). Rotate drum to seat bearings. Loosen nut $1\frac{1}{8}$ - $1\frac{1}{6}$ turn. If brake drum rotates properly, install lock washer and tighten lock nut with suitable tool (09607-60010).

Pickup — Tighten front axle castle nut to 36 ft. lbs. to seat bearings, then back off until nut is finger tight. Retighten nut to 36 ft. lbs. and back off $\frac{1}{6}$ - $\frac{1}{3}$ turn and install cotter key. When properly adjusted, bearing preload should be as shown in table, when checked with pull scale attached to hub bolt.

All Other Models — Tighten castle nut bearing retainer nut 18.8-23.2 ft. lbs. and turn brake drum back and forth to seat bearing. Loosen nut until can be turned with fingers. Tighten nut to finger tight using a socket without the handle. If not aligned for cotter key installation, tighten until installation possible. Preload at hub (hub rotating) should be within specifications.

Bearing Preload Specifications

Application	Preload (Oz)
Corona	12.3-30.6
Pickup	18.6-61.8
All Others	10.6-24.7

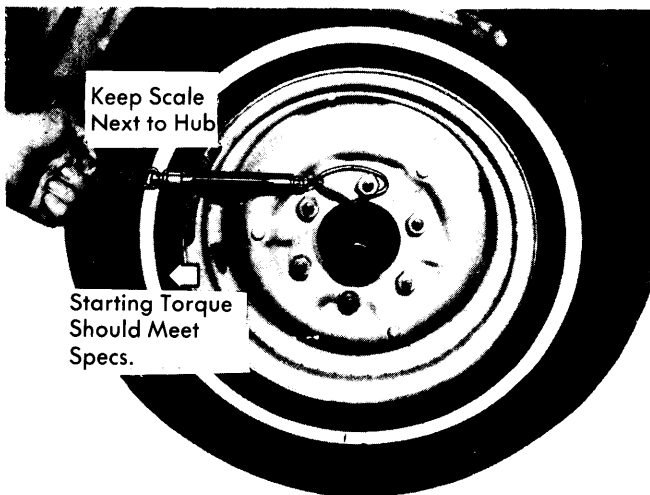

Fig. 1 Using a Pull Scale to Measure Wheel Bearing Starting Torque

TRIUMPH

TR7 — Raise and support front of vehicle, then remove wheel and tire. Check hub for excessive end play. If adjustment is necessary, remove grease cap and cotter key. Tighten spindle nut to 5 ft. lbs. (.7 mkg), then back nut off one flat and install cotter key.

All Others — Raise and support front of vehicle, then remove wheel and brake caliper. Attach a dial indicator and measure wheel bearing end play. If end play exceeds .003-.005" (.08-.13 mm), remove cotter key and loosen or tighten spindle nut until end play is within specifications. Install new cotter key.

VOLKSWAGEN

Type 1 (Front) — Raise and support front of vehicle. While rotating wheel, tighten spindle clamp nut to seat bearings. Loosen clamp nut until axial play is .001-.005" (.025-.027 mm). Tighten clamp nut.

Type 2 (Front) — Adjust clamp nut while rotating wheel. Adjustment is completed when thrust washer can be moved with a screwdriver and finger pressure.

All Other Models (Front) — Front wheel bearings are pressed into bearing housing and no adjustment is necessary. Tighten front axle nut to 167 ft. lbs. (23 mkg) on Dasher models or 175 ft. lbs. (24.2 mkg) on Rabbit and Scirocco models.

Dasher, Rabbit & Scirocco (Rear) — Wheel bearings are correctly adjusted if thrust washer can be moved slightly with a screwdriver. **NOTE** — This will provide axial play of approximately .001-.003".

VOLVO

All Models — While rotating hub, torque nut to 50 ft. lbs. Loosen nut $\frac{1}{3}$ turn and check for hub rotating freely with no end play. If necessary to align cotter key holes loosen nut and install cotter key.

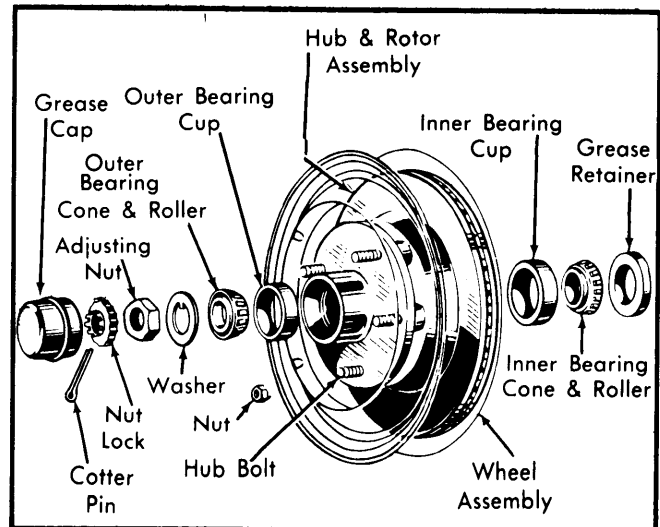

Fig. 2 Exploded View of Wheel Bearing Components with Disc Brakes