

## SUBARU (Cont.)

Raising vehicle height is accomplished by turning outer end and inner end of torsion bar in direction opposite to cast-in arrow on outer end of bar. Height changes .20" (5mm) per each serration shifted.

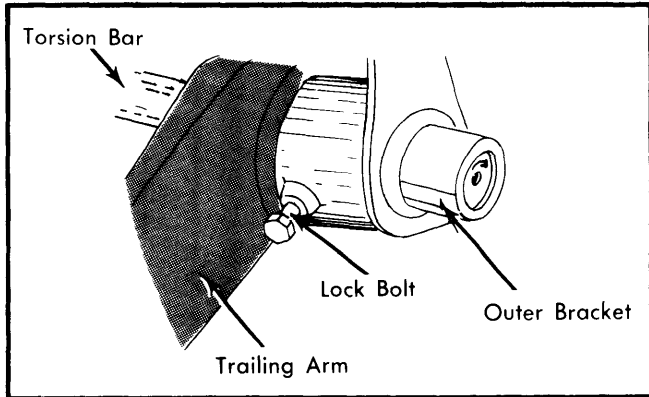

**Fig. 1 Installed View of Torsion Bar Outer End Attachment**

1) Initially set vehicle rear riding height by inserting torsion bar with its missing serration aligned with markings on outer bracket surface and trailing arm inner surface. This will give approximately the specified riding height as indicated in table.

2) Measure road clearance from center of trailing arm bushing to ground. **NOTE** — Vehicle must be in unloaded condition. Raise rear of vehicle and remove rear wheel.

3) Unscrew shock absorber lower mounting nut and remove it from trailing arm. Unscrew lock bolt on outer bushing.

4) Scribe mark position of torsion bar by making a mark on upper half of inner end surface and lower half of outer end surface. Outer end surface mark should be continued onto trailing arm shaft and outer bracket boss.

5) Holding trailing arm so torsion bar does not twist, disengage serrations by tapping inner end surface of torsion bar See Fig. 2.

6) Pull torsion bar out of trailing arm. Determine amount of turn necessary to make proper height adjustment and turn inner end of torsion bar to this value. Then, insert outer end of torsion bar to its proper adjusted position.

7) Install rear wheel and lower vehicle. Reattach lower end of shock absorber. Recheck vehicle rear ground clearance as originally measured. If correct, tighten lock bolt on outer trailing arm bushing. If incorrect, repeat adjustment.

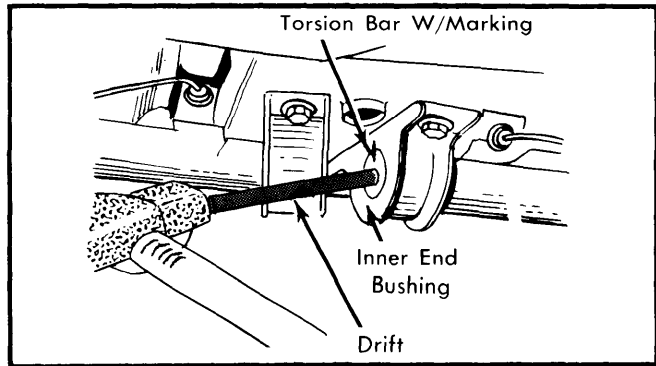

**Fig. 2 View Showing Removal Procedure for Torsion Bar**

### Rear Riding Height Specifications

Application	Height
1600 Sedan.....	11.34-11.89" (288-302 mm)
Station Wagon.....	12.21-12.76" (310-324 mm)
4WD Station Wagon.....	14.17-14.76" (360-375 mm)

### CASTER

Caster angle is not adjustable. If angle is not to specifications, inspect suspension for wear or damage and repair or replace components as necessary.

### CAMBER

**All Models (Front)** — Camber angle is not adjustable. If angle is not to specifications, inspect suspension for wear or damage. Repair or replace components as necessary.

**All Models (Rear)** — Camber angle is adjusted by altering number of shims inserted between torsion bar bracket and chassis mounting. Fitting shims changes camber to negative and removing shims changes camber to positive. One shim corresponds to 1/4° adjustment.

### TOE-IN

**All Models (Front)** — If toe-in is not within specifications, loosen steering link (tie rod) lock nut and turn sleeve until correct toe-in is obtained.

**All Models (Rear)** — If toe-in is not within specifications, loosen bolts holding torsion bar bushing to body. Bushing is fixed to body at elongated holes. Moving bushing forward decreases toe-in and moving it rearward increases toe-in. Tighten bolts and recheck toe-in.

## TOYOTA

### ADJUSTMENT

#### TIRE INFLATION (COLD)

Before attempting to check or adjust wheel alignment, make sure tires are properly inflated. Refer to manufacturers specifications given in owner's manual.

### RIDING HEIGHT

**Corona** — Place vehicle on level surface. Bounce several times and allow suspension to settle. Check riding height dimensions (See Fig. 1) and if not within specifications, inspect suspension components. Replace or repair parts as required.

# Wheel Alignment

## TOYOTA (Cont.)

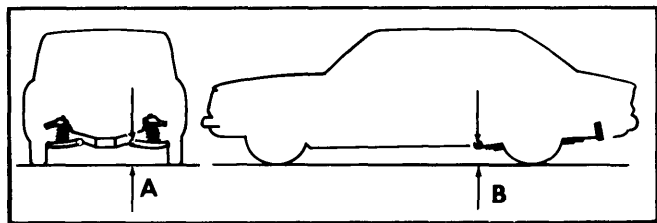

Fig. 1 Front & Rear Suspension Riding Height Measuring Points

### Riding Height Specifications

Application	A In. (mm)	B In. (mm)
Corona		
Sedan & Hdtop .....	9.92 (252)	9.01 (229)
Wagon .....	9.92 (252)	10.0 (254)

### CASTER

**Corona** — **NOTE** — *Camber and caster adjustments should always be made in one operation.* If caster angle is not within specifications, adjust eccentric on front of lower control arm.

**Pickup** — **NOTE** — *Camber and caster adjustments should always be made in one operation.* If caster angle is not within specifications, adjust by adding or removing shims between the upper control arm shaft and the front suspension crossmember. To increase caster, add shims to rear side of the upper control arm shaft mounting bolt or remove shims from the front side. To decrease caster, reverse procedure.

**All Other Models** — Caster angle is not adjustable. If caster angle is not within specifications, inspect front suspension for wear or damage and repair or replace components as necessary.

### CAMBER

**Corona** — **NOTE** — *Caster and camber adjustments should always be made in one operation.* If camber angle is not within specifications, adjust eccentric on rear of lower control arm.

**Pickup** — **NOTE** — *Caster and camber adjustments should always be made in one operation.* If camber angle is not within specifications, adjust by adding or removing shims between upper control arm shaft and the front suspension crossmember. To increase camber angle, remove shims from, upper control arm shaft bolts in equal amounts. To decrease camber, reverse procedure.

**All Other Models** — Camber angle is not adjustable. If camber angle is not with specifications, inspect front suspension for wear or damage and repair or replace components as necessary.

### TOE-IN

**All Models** — If toe-in is not within specifications, loosen steering link (tie-rod) clamping bolts and rotate adjusting sleeves an equal amount until correct toe-in is obtained. Position clamp bolts at right angles to slot in tie rod and tighten bolts.

## TRIUMPH

### ADJUSTMENT

#### TIRE INFLATION (COLD)

Before attempting to check or adjust wheel alignment, make sure tires are properly inflated. Refer to manufacturers specifications given in owner's manual.

#### CASTER

**All Models** — Caster angle is not adjustable. If caster angle is not to specifications, inspect suspension system for wear or damage and repair or replace components as necessary.

#### CAMBER

**All Models (Exc. TR7)** — Before adjusting camber angle, inspect suspension for wear or damage and repair or replace components as necessary. To adjust, raise vehicle and support chassis on jack stands. Loosen nuts securing lower control arm bracket to chassis. Add shims equally to front and rear of

bracket to decrease camber, or remove shims equally to increase camber angle. After each adjustment is made, tighten bracket-to-chassis bolts, remove jack stands and measure camber angle.

**TR7** — Camber angle is not adjustable. If camber angle is not within specifications, inspect suspension system for wear or damage and repair or replace components as necessary.

#### TOE-IN

**All Models (Front)** — Set front wheels in straight ahead position. If adjustment is necessary, loosen steering link (tie rod) lock nuts and gaiter clips. Rotate adjusting sleeves equal amounts until correct toe-in is obtained. Tighten lock nuts and recheck toe-in.

**Spitfire (Rear)** — If toe-in is not to specifications, loosen bolts holding strut front support. Adjust as necessary by adding to or removing from the shims fitted between support and body. Tighten bolts and recheck toe-in.