

TRIUMPH

Spitfire
TR7

DESCRIPTION

All models use front disc and rear drum brakes. A tandem piston master cylinder which consists of two independent and complete hydraulic circuits is used. A pressure differential valve is used on all models to detect low pressure in either front or rear brake systems. When a pressure differential exists between the two circuits, indicating a failure, the pressure differential valve completes the circuit to the brake failure warning light on the instrument panel. A vacuum servo unit for power braking is also used on some models.

ADJUSTMENT

DISC BRAKES

No adjustment required.

DRUM BRAKES

Spitfire — Release parking brake and raise rear wheels off ground. Rotate rear wheel clockwise while tightening adjuster. After wheel locks back off adjuster until wheel is just free to turn.

PARKING BRAKE

NOTE — Adjustment of rear brakes will normally provide satisfactory parking brake adjustment. If cables are stretched, further adjustment is performed as follows:

- 1) Hoist vehicle in rear, release parking brake and lock both rear brake drums with adjusters. Remove clevis pins from levers on brake back plates.
- 2) Adjust each clevis equal amounts until clevis pin can be easily inserted to relay levers. Secure clevis pins and check operation. **NOTE** — If system is equipped with return spring, adjust bracket to provide proper tension.

HYDRAULIC SYSTEM BLEEDING

NOTE — TR7 system incorporates a self-centering Pressure Differential Shuttle. On all others, hard pedal application will cause shuttle to go over-center and warning light be activated.

- 1) Attach a bleed tube to wheel cylinder farthest from master cylinder and submerge free end into a half full container of brake fluid.
- 2) On TR7 models, remove pressure differential switch. Open bleed valve and FULLY depress brake pedal, then follow with three rapid, successive strokes.
- 3) On Spitfire models, open bleed valve and lightly depress brake pedal, but DO NOT allow pedal to make complete stroke.
- 4) Continue either steps 2) or 3) until all air is bled from brake system.

Bleeding Sequence

Application	Sequence
Spitfire	RR,LR,RF,LF
TR7	RF,LF,RR,LR

REMOVAL & INSTALLATION

DISC BRAKE PADS

Removal — Raise vehicle and remove front wheels. Withdraw the two retaining pins and springs. Lift out brake pads complete with damper shims.

Installation — Clean surfaces of pistons and caliper cavity. Ease caliper pistons into bores to provide clearance. **NOTE** — Brake fluid will raise during this operation. Insert new pads and shims. On TR7 models only, larger cut outs face upper most in cylinder recess. On Spitfire models only, arrow on disc pad faces UP. Insert retaining pins and secure in place.

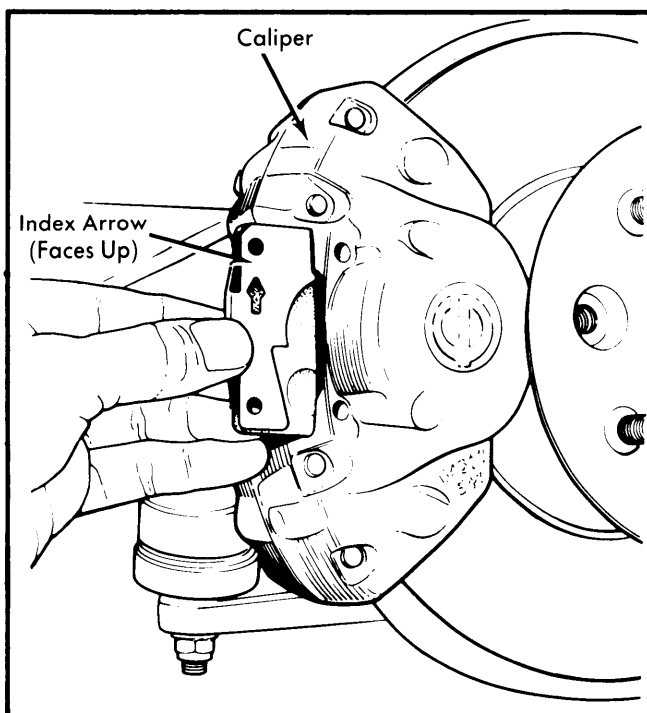

Fig. 1 Installing Disc Brake Pad on Spitfire Models

MASTER CYLINDER

Removal — Disconnect all hydraulic lines from master cylinder. On models equipped with power brake unit, remove mounting nuts and spring washers, then pull cylinder off studs. On models without power unit, disconnect master cylinder push rod from brake pedal. Remove four mounting bolts securing cylinder to mounting bracket. Take off bolt mounting master cylinder flange to bracket and withdraw entire assembly.

Installation — To install master cylinder assemblies, reverse removal procedure and bleed brake system.

TRIUMPH (Cont.)

VACUUM SERVO UNIT

Removal & Installation – Remove master cylinder as previously outlined. Disconnect vacuum hose from check valve. Remove clevis pin from servo operating rod and brake pedal lever. Remove servo with spacer. To install, reverse removal procedure.

DISC BRAKE CALIPER

Removal – Disconnect brake union at caliper and plug opening in line. On Spitfire models, remove two bolts mounting caliper assembly to stub axle. On TR7 models, remove two bolts mounting steering arm and caliper lower mounting to stub axle assembly. Push steering clear, then remove upper mounting.

Installation – To install caliper assembly, reverse removal procedure and torque mounting bolts. Bleed hydraulic system.

BRAKE DISC (ROTOR)

Removal – Raise front of vehicle and place on safety stands; remove tire. Disconnect and remove brake caliper; hang out of way. Remove grease cap and cotter pin. Take off mounting nut and washer. Withdraw complete disc assembly, then remove the four bolts and spring washers securing disc to hub.

Installation – To install, reverse removal procedure and torque all nuts and bolts. Install wheel bearing seal as required. Hub end play on Spitfire models must be approximately .002-.005" (.051-.127 mm). On TR7 models, eliminate end play as required, but DO NOT tighten hub nut more than 5 ft. lbs. (.69 mkg).

REAR BRAKE DRUM

Removal & Installation – Hoist vehicle and remove rear wheel. Remove two countersunk screws securing brake drum to hub. Release parking brake and remove brake drum. To install, reverse removal procedure.

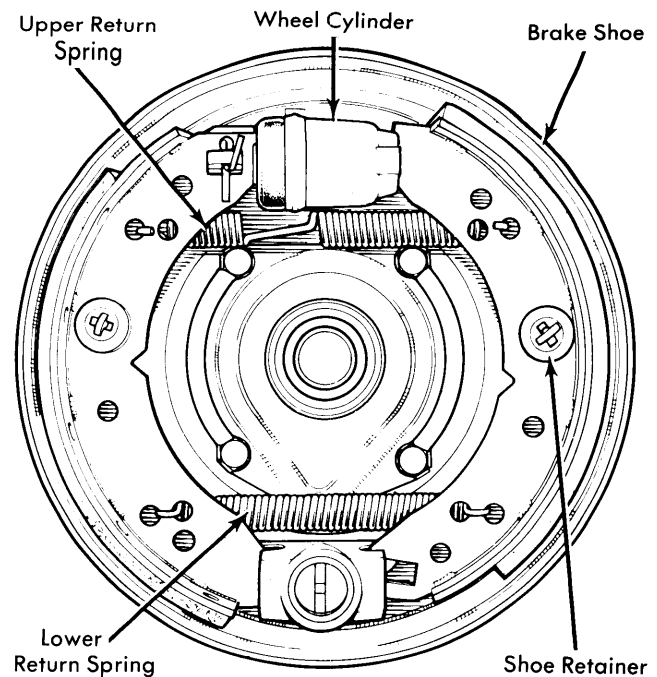

Fig. 2 Assembled View of Triumph Spitfire Rear Drum Brake Unit

REAR BRAKE SHOES

Removal – Remove brake drum as previously outlined. Remove parking brake cotter pin, shoe anchor pins, cups and springs. Disconnect return springs and lift shoes from abutments. Disconnect front shoe from parking brake lever and remove shoes.

Installation – Reverse removal procedure and lightly apply white grease (zinc base) to ends of shoes and cam faces.
CAUTION – Do not allow grease to contact lining material. Readjust brakes when lining replacement is complete.

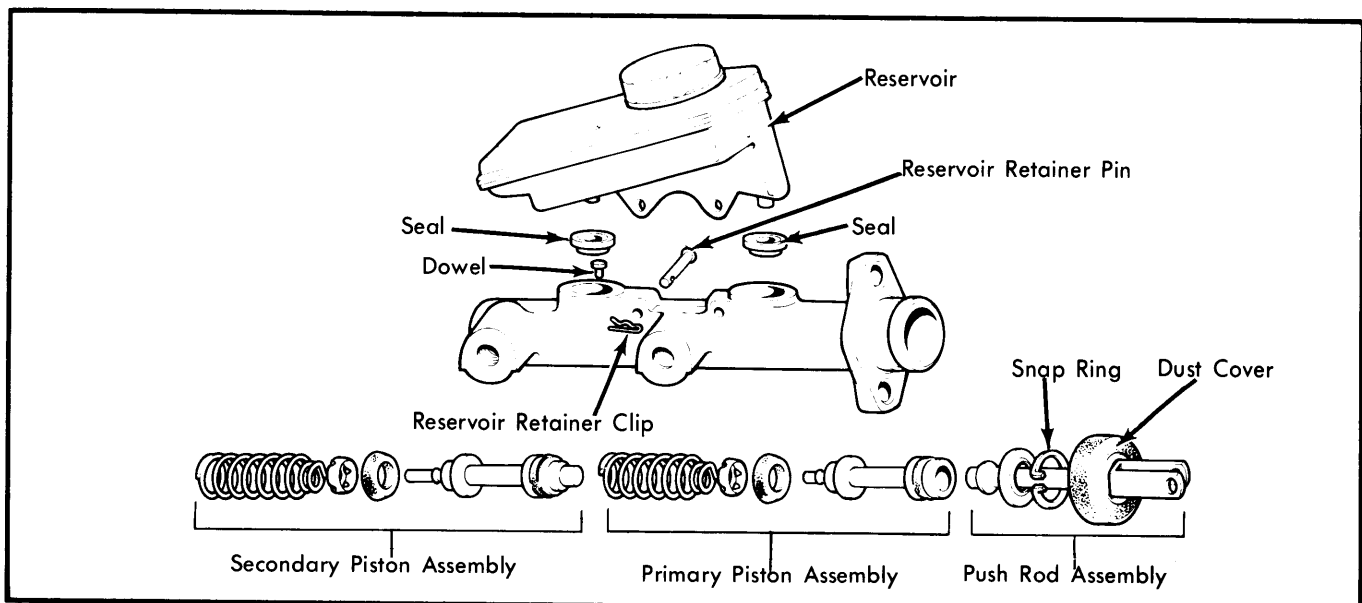

Fig. 3 Exploded View of Master Cylinder – Spitfire Shown

TRIUMPH (Cont.)

REAR BRAKE WHEEL CYLINDER

Removal & Installation — Remove brake shoes as previously outlined. Drain fluid, disconnect flex hose from steel line and unscrew hose from cylinder. Disconnect parking brake cable clevis, remove dust cover, retaining plate and spring clips. Remove wheel cylinder. To install, reverse removal procedure and bleed brakes.

PRESSURE DIFFERENTIAL VALVE

Removal & Installation — Disconnect electrical leads. Disconnect inlet and outlet lines and plug all ports to prevent loss of fluid and entry of dirt. Remove bolt securing valve and remove unit. To install, reverse removal procedure, bleed brakes and if necessary, center valve shuttle.

OVERHAUL

DISC BRAKE CALIPER

Disassembly — Using low air pressure, force pistons from caliper bores. If pistons are seized, the whole caliper assembly must be renewed. Carefully pry wiper seal retainer from groove, using a blunt instrument. **NOTE** — *Spitfire* uses circlips for retainers. Take out wiper seal and then fluid seal.

Inspection — Clean caliper bores and inspect for deep scratches or pitting. Look at pistons and ensure they are not corroded or damaged. Replace components as necessary.

Reassembly — Fit new fluid seals into caliper bores, making sure they are properly located. Lightly coat bores with clean brake fluid. Insert pistons into calipers, with approximately $\frac{5}{16}$ " (7.94 mm) of each piston protruding from mouth of each bore. Fit new wiper seal into each retainer, then slide assembly, seal first, into mouth of bore. **NOTE** — Use piston as a guide for seal. On *Spitfire* models, insert dust seals and install circlip. Fully seat pistons, ensuring retainers are not distorted.

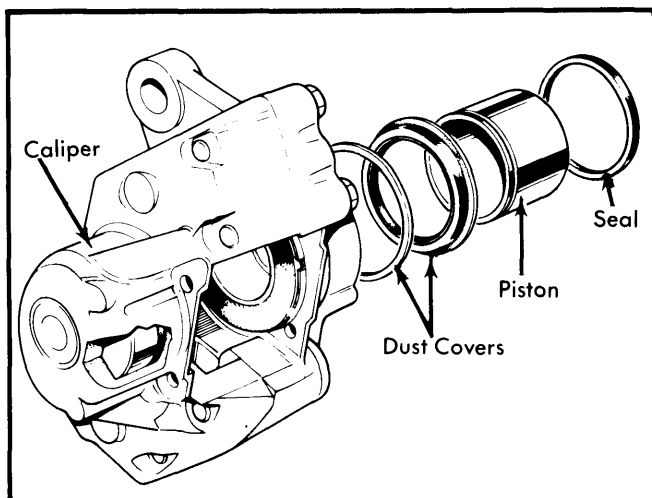

Fig. 4 Disassembled Front Disc Brake Caliper
Spitfire Shown

REAR WHEEL CYLINDER

Disassembly — Remove wheel cylinder as previously outlined. Remove dust cover and withdraw piston. Remove seal from piston using fingers only.

Cleaning & Inspection — Clean all parts in alcohol or brake fluid and examine cylinder bore and piston for score marks, ridges or corrosion. If either bore or piston is damaged, replace entire cylinder assembly.

Reassembly — Install new seal with lip towards bottom of cylinder. Lubricate seal with clean brake fluid, insert piston into cylinder and install dust cover. Reinstall cylinder and bleed brakes.

VACUUM SERVO UNIT

NOTE — Overhauling unit consists of changing check valve, filter, dust cover, seal and plate assembly. Any other component failure requires complete unit replacement. Replacing filter is the only normal service required. A service repair kit is available for limited service.

Disassembly — 1) Remove servo unit as previously outlined. To remove check valve, note angle of valve in relation to servo housing. Use a suitable wrench to press down on valve and rotate counterclockwise $\frac{1}{3}$ turn.

2) Remove filter by pulling back dust cover and pulling out filter. For ease of filter installation, cut new filter diagonally.

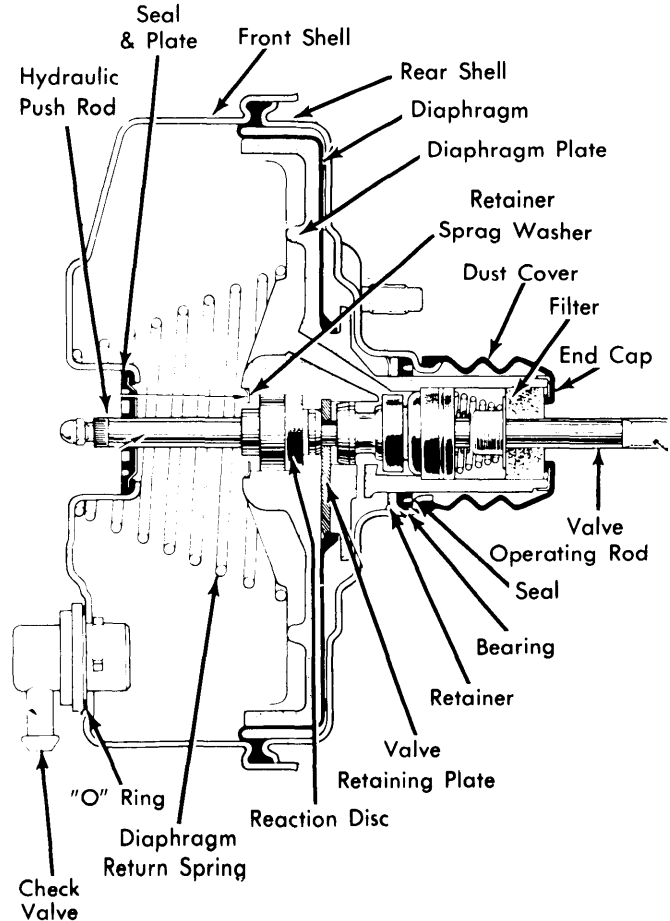

Fig. 5 Sectional View of Vacuum Servo Unit

TRIUMPH (Cont.)

3) Remove seal and plate assembly from front shell recess by gripping center rib with needle nose pliers. Use grease supplied in service kit to lubricate new seal and plate assembly when installing.

4) To check push rod for wear, place a straight edge across front shell recess. Measure clearance between end of push rod and straight edge. Clearance should be .011-.016" (.28-.41mm). Replace servo unit if clearance is incorrect.

NOTE — Servo push rod to master cylinder clearance is set by factory and secured with Loctite. No attempt should be made to alter setting.

Reassembly — To reassemble components to servo unit, reverse disassembly procedures.

MASTER CYLINDER

Disassembly, Spitfire — 1) Remove master cylinder as previously outlined. Drain and discard fluid. Remove screws securing reservoir to cylinder. Depress push rod, remove snap ring and withdraw push rod with abutment plate. Use an Allen wrench to unscrew tipping valve securing nut and remove seal. Depress primary plunger and remove tipping valve.

2) Remove internal parts either with compressed air at inlet or by shaking cylinder body. Separate plunger and intermediate spring. Lift leaf of spring retainer, remove spring and center

valve sub-assembly from secondary plunger. From valve stem, remove spring, valve spacer, spring washer and valve seal. Remove seals from primary and secondary plungers.

Cleaning & Inspection — Clean all serviceable parts in brake fluid or alcohol. Examine cylinder bore for score marks, ridges or corrosion. Discard cylinder body even if only slight imperfections are found.

NOTE — Replace all seals with those contained in service repair kit. Prior to assembly, lubricate all parts in clean brake fluid.

Reassembly — 1) Install seal on primary and secondary plungers. Install seal, smaller diameter leading, to valve head. Place spring washer on valve stem ensuring that convex side of washer is to valve. Place spring retainer to valve stem with keyhole leading. Slide secondary spring over spring retainer and up to secondary plunger.

2) Place secondary plunger and valve assembly between protected jaws of a vise and compress spring. Use a small screwdriver to press leaf spring retainer against secondary plunger and then compress leaf spring retainer with needle nose pliers against plunger. Remove plunger and valve assembly from vise and check retainer spring.

3) Install intermediate spring between primary and secondary plungers and insert into cylinder. Replace push rod, snap

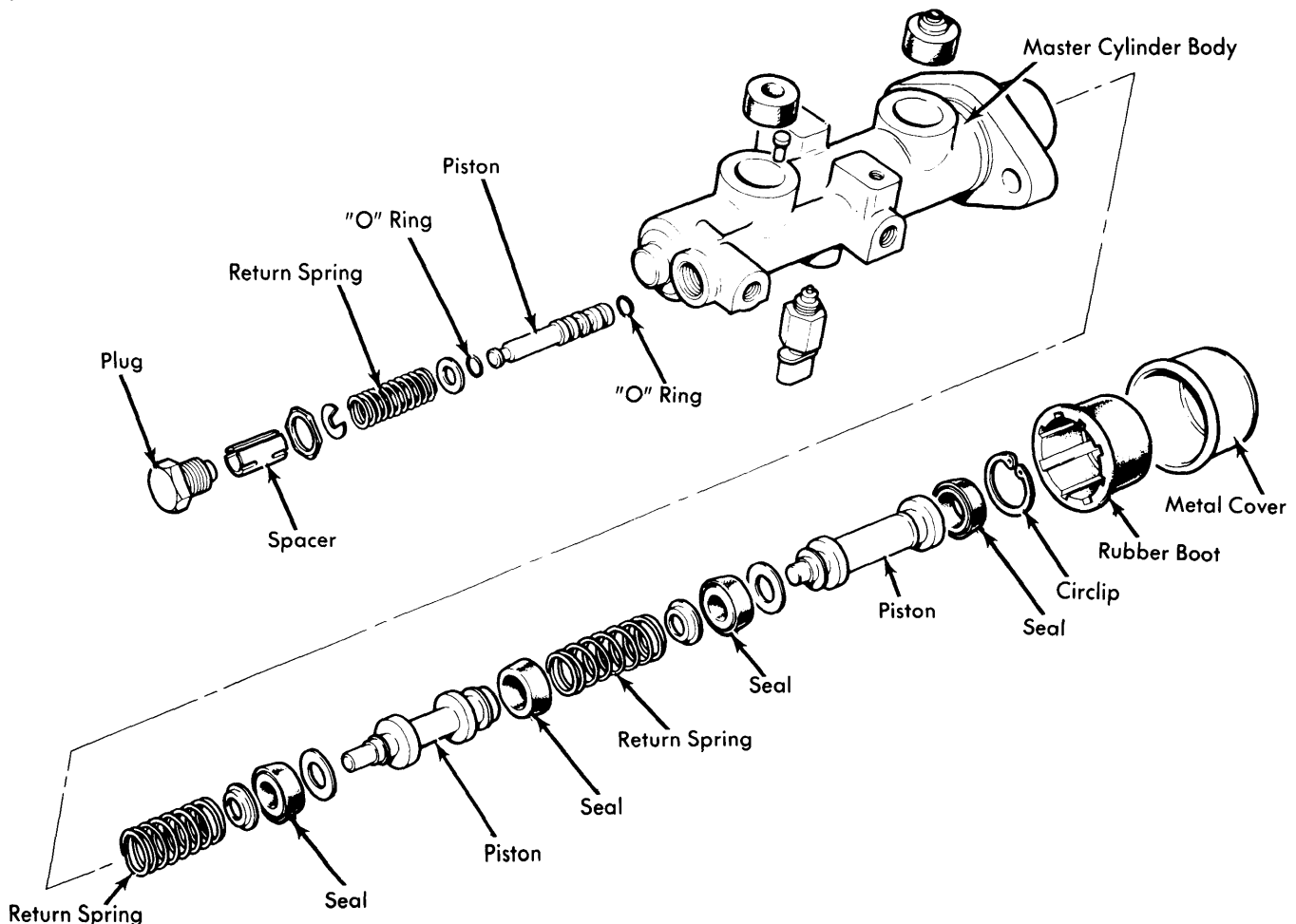

Fig. 6 Exploded View of Master Cylinder Assembly

Brakes

TRIUMPH (Cont.)

ring and rubber boot. Depress push rod and insert tipping valve. Install seal, secure nut and torque to specifications. Install reservoir and seal. Install master cylinder and bleed brakes.

Disassembly, TR7 – 1) Separate fluid reservoir from master cylinder. Pull out rubber seals from cylinder body. Take off metal cap and rubber boot, then disengage circlip and pull out primary piston assembly.

2) Insert a rod into bore and depress secondary piston. This releases stop pin for removal. Withdraw secondary piston, spring retainer and return spring.

3) Unscrew failure switch from cylinder body. Remove end plug and extract washer, spacer and piston with spring. Carefully separate rubber seals.

Inspection – Clean all components in brake fluid, then thoroughly dry. Carefully inspect all components for wear. If cylinder bore is even slightly corroded, cylinder must be replaced. Ensure all fluid passages are unobstructed.

Reassembly – 1) Fit new seals and washers to primary and secondary pistons. Insert secondary return spring, spring retainer, and piston into cylinder bore.

2) Using a rod, depress secondary piston until head of piston passes secondary fluid port, then fit stop bolt. Fit primary return spring, spring retainer and piston into bore. Be sure lip of seal is not bent back.

3) Fit circlip at mouth of cylinder and check for correct seating in groove. Reinstall both rubber seals into cylinder body recesses. Ensure reservoir is clean and fit to master cylinder.

4) Fit new "O" rings into grooves on pressure warning switch piston and spring assembly. Insert assembly into bore and take care not to damage "O" rings. Install spacer, fuel line, copper washer, and end plug.

TIGHTENING SPECIFICATIONS

Application	Ft. Lbs. (mkg)
Disc Brake Rotor-to-Hub	
Spitfire	26-34 (3.6-4.7)
Disc Brake Caliper-to-Mount Plate	
Spitfire	50-65 (7.0-9.0)
Master Cylinder Tipping Valve Nut.....	35-40 (4.8-5.5)

DISC BRAKE ROTOR SPECIFICATIONS

Application	Disc Diameter In. (mm)	Lateral Runout In. (mm)	Parallelism In. (mm)	Original Thickness In. (mm)	Minimum Refinish Thickness In. (mm)	Discard Thickness In. (mm)
Spitfire	9.000 (229)
TR7	9.76 (247.6)375 (9.5)

BRAKE DRUM SPECIFICATIONS

Application	Drum Diameter In. (mm)	Original Diameter In. (mm)	Maximum Refinish Diameter In. (mm)	Discard Diameter In. (mm)
Spitfire	7.000 (178)	7.000 (178)
TR7	7.995-8.000 (203.2-203.3)	7.995-8.000 (203.2-203.3)	...	8.050 (204.5)