

SAAB

99

DESCRIPTION

Brake system is hydraulically operated by a tandem master cylinder and power brake unit. Front disc brakes are Girling type consisting of a brake rotor and dual piston, fixed caliper (sliding yoke). Rear brakes are either Girling type with sliding yoke or ATE dual piston type. Parking brake is mechanically actuated and works on FRONT brake assemblies.

ADJUSTMENT

DISC BRAKES

Disc brakes are self adjusting; therefore, no adjustment in service is required.

PARKING BRAKE CABLE

Before adjusting cable, apply brake lever several times to stretch cables. Rotate cable adjusting nuts located at rear of parking brake lever under plastic cover until distance between lever on front caliper and yoke is .016-.022" (.41-.56 mm). Check distance with parking brake fully released.

NOTE — Parking brake cables are crossed, so to adjust left parking brake mechanism (cable), right adjusting nut must be rotated and vice versa.

HYDRAULIC SYSTEM BLEEDING

Connect bleeder tube to bleeder screw, and submerge open end of tube in a jar half full of clean brake fluid. Open bleeder screw, and push brake pedal down quickly, allowing it to return slowly. Repeat procedure until fluid flows from bleeder tube with no sign of air. On last downward stroke, close bleeder screw. Bleeding sequence is left-rear, right-front, right-rear, left-front.

REMOVAL & INSTALLATION

DISC BRAKE PADS

Removal, Girling Type — Rotate brake rotor until one of the recesses in edge of rotor is aligned with brake pads. Remove damper spring, pin retaining clips and retaining pins, then lift out brake pads.

Installation — Open bleeder screw and press pistons back into caliper bore, then close bleeder screw. **NOTE** — On the front brakes, it will be necessary to rotate direct piston while pressing it into caliper bore. Insert brake pads into caliper, then install retaining pins, clips and damper spring. After installation, apply brake pedal several times to position pads against rotor.

Removal, ATE Type — Clean outside of caliper housing. Turn rotor until recess in edge of rotor is inline with pad. Remove cover plate, mounting pins and spring that retains brake pads. Pull pads out of caliper.

NOTE — If pads are seized, use suitable extractor tool (8995771) to remove pads.

Installation — Seat pistons in bores. Insert new pads. Install spring, lock pins, and cover plate. Pump pedal several times to ensure proper brake operation is taking place.

DISC BRAKE CALIPER

Removal — Raise and support vehicle and remove wheels. On front wheel calipers, disconnect parking brake cable from lever on caliper. On all wheels, disconnect hydraulic line from hose, then plug lines to prevent entry of dirt and loss of fluid. Remove caliper attaching bolts and lift off caliper.

Installation — To install, reverse removal procedure and note the following: Tighten all attaching bolts, bleed hydraulic system and adjust parking brake cables.

DISC BRAKE ROTOR

Removal (Front) — Apply parking brake and remove rotor and hub attaching nut from spindle, then release parking brake. Remove caliper assembly (without disconnecting hydraulic line) and support out of way. Using a puller, remove rotor and hub assembly from spindle. Remove the four attaching bolts and separate rotor from hub.

Removal (Rear) — Remove caliper assembly (without disconnecting hydraulic line) and support out of way. Remove the two rotor attaching bolts and lift off rotor.

Installation (Front & Rear) — To install, reverse removal procedure and note the following: Tighten all nuts and bolts and adjust parking brake if necessary.

MASTER CYLINDER

Removal — Disconnect electrical lead to warning switch on master cylinder. Disconnect clutch master cylinder hose from fluid reservoir, then plug reservoir nipple to prevent loss of fluid. Disconnect hydraulic lines from master cylinder. Remove master cylinder-to-power brake unit attaching nuts and lift off master cylinder.

Installation — To install, reverse removal procedure and bleed hydraulic system.

POWER BRAKE BOOSTER

Removal — From inside engine compartment, remove upper circlip from brake pedal push rod. Disconnect all electrical leads, hydraulic lines and vacuum lines from master cylinder and power brake unit. Remove the four attaching nuts and lift off master cylinder and power unit as an assembly. **NOTE** — Three attaching nuts are removed from inside vehicle while the fourth nut is removed from engine compartment. Separate master cylinder from power unit.

Installation — To install, reverse removal procedure and bleed hydraulic system.

OVERHAUL

FRONT CALIPER ASSEMBLY

Disassembly, Girling Type — 1) With caliper removed from vehicle, mount assembly in a soft jawed vise. Remove parking brake return spring. Then remove yoke from caliper assembly and spring and parking brake lever from yoke.

SAAB (Cont.)

2) Remove retaining ring and dust boot, then using compressed air, force out indirect piston assembly from caliper. Press direct piston push rod and remove piston from caliper. Remove "O" rings and seal rings from caliper bore and pistons.

Cleaning & Inspection – Clean all parts, except indirect piston assembly, in clean brake fluid and dry with a clean, lint-free cloth. **NOTE** – Indirect piston assembly should only be wiped clean to prevent washing off parking brake mechanism lubricant. Inspect all parts for wear, damage or corrosion and replace as necessary. **NOTE** – Manufacturer recommends replacing all rubber parts whenever caliper assembly has been disassembled.

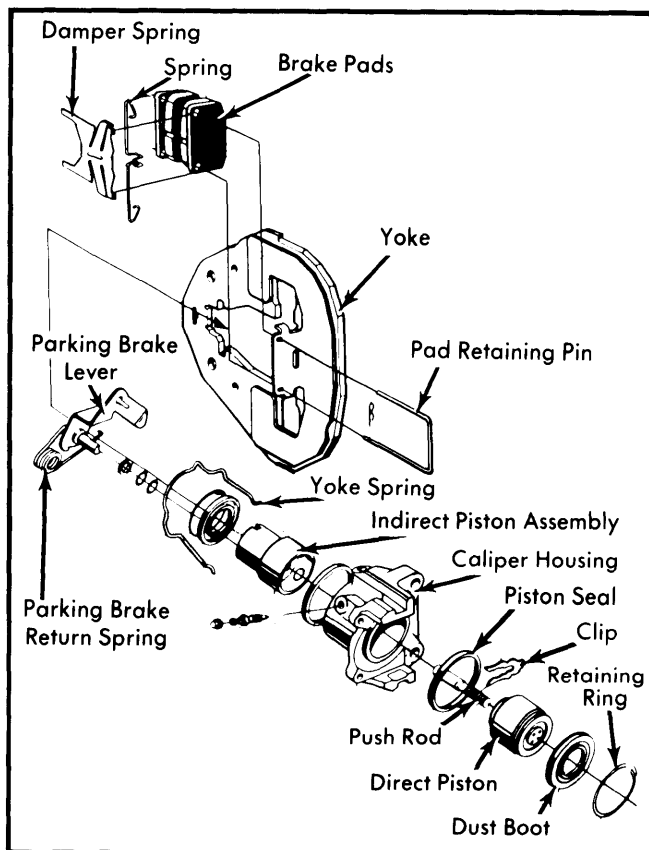

Fig. 1 Exploded View of Girling Front Brake Caliper

Reassembly – 1) Lubricate pistons and caliper bore with clean brake fluid, then install new "O" rings and seal rings to pistons and caliper bore. Install indirect piston into caliper with recess for yoke aligned with groove in caliper housing, then install direct piston in the same manner. Press in indirect piston and screw in direct piston until edges of dust boot grooves are flush with caliper housing.

2) Install dust boots and retaining rings. Fit yoke spring and parking brake lever to yoke, then align yoke guide edges with groove on caliper housing and install yoke. Lift parking brake lever and install axle pin into hole in indirect piston. **NOTE** – Ensure yoke fits into recess of indirect piston. Install parking brake return spring. Check clearance between sliding surfaces

of yoke and caliper housing; clearance on one side should be .006-.012" (.15-.30 mm), while there should be no clearance on the other side (see illustration).

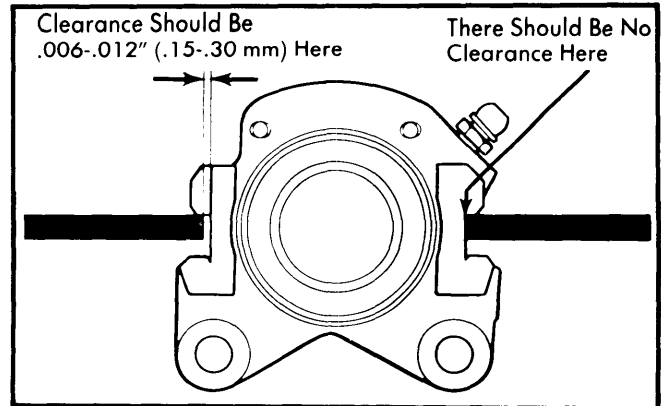

Fig. 2 Girling Front Brake Caliper Clearance Measuring Points

REAR CALIPER ASSEMBLY

Disassembly, Girling Type – 1) With caliper assembly removed from vehicle, mount assembly in soft jawed vise. Remove yoke from caliper assembly by lifting it toward bleeder screw. Then remove yoke spring.

2) Remove retaining ring and dust boot. Using compressed air, force indirect piston from caliper assembly. Push direct piston from caliper assembly. Remove piston seals from caliper bore.

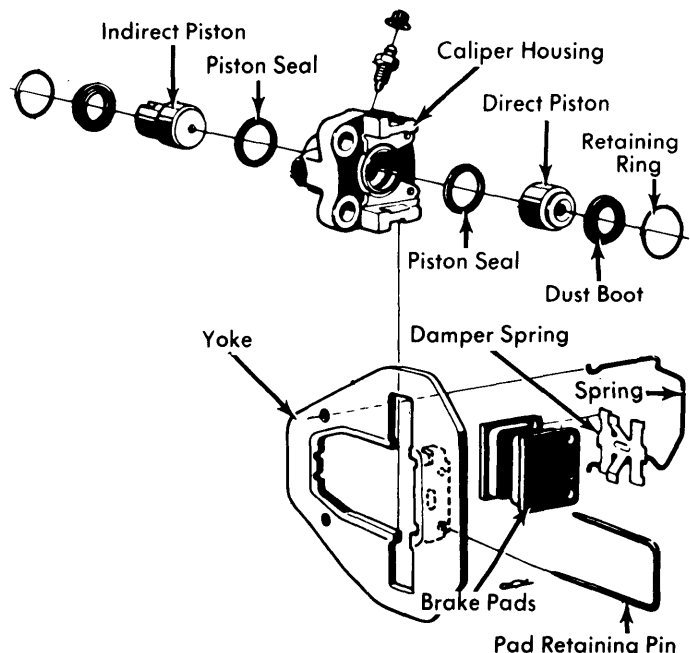

Fig. 3 Disassembled Girling Rear Brake Caliper Showing Internal Component Relationships

SAAB (Cont.)

Cleaning & Inspection – Clean all parts in clean brake fluid and dry with a clean, lint-free cloth. Inspect all parts for wear, damage or corrosion and replace as necessary.

Reassembly – Lubricate caliper bore with clean brake fluid and install new piston seals. Press pistons into caliper bore, then rotate indirect piston until recess for yoke is aligned with groove in caliper housing. Install new dust boot and retaining ring. Install yoke spring on yoke, then install yoke into groove of caliper housing and indirect piston. Check clearance between sliding surfaces of yoke and caliper housing; clearance should be .006-.012" (.15-.30 mm) on bleeder screw side of caliper housing (see illustration).

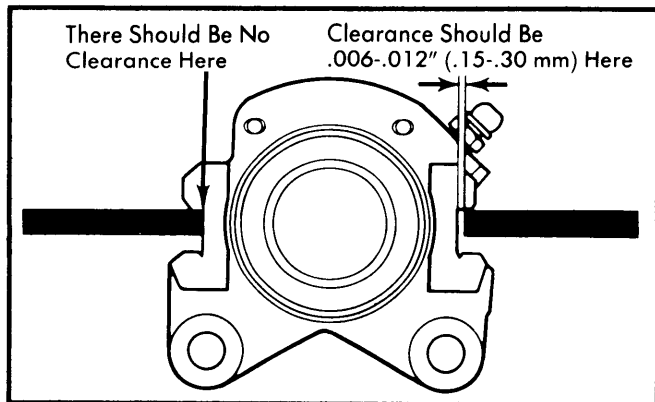

Fig. 4 Girling Rear Brake Caliper Clearance Measuring Points

Disassembly, ATE Type – 1) Clean outside of caliper assembly. Remove pads and caliper as previously outlined. Using suitable clamp (7841323), secure one piston in bore. Apply air pressure to fluid inlet port and force out piston.

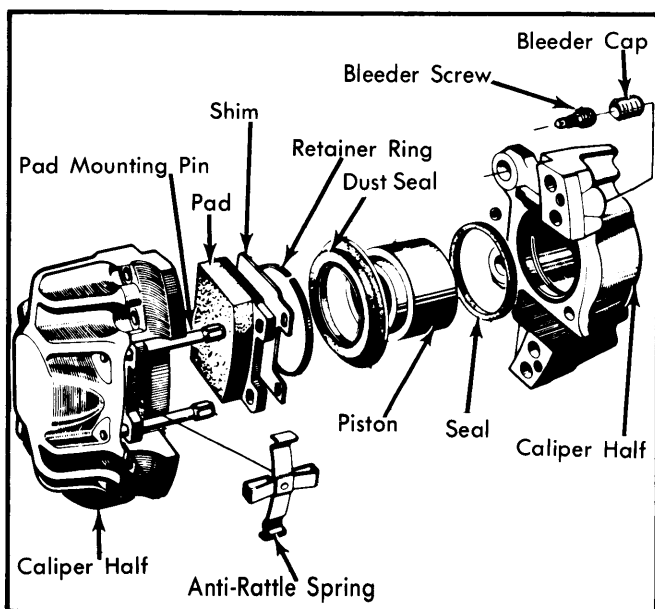

Fig. 5 Exploded View of ATE Type Rear Caliper

2) Carefully remove seals from cylinder bore using a pointed but not sharp instrument. Make sure seal groove is not damaged when removing seal.

NOTE – Before second piston can be removed and seal replaced, reassembly operation must be completed on first piston.

Reassembly – Lubricate caliper bore with clean brake fluid and slide new seal into machined groove. Lubricate piston with brake fluid and fit it into cylinder. Install new dust seal and retainer ring. Seat piston into bore and begin disassembly of other piston.

MASTER CYLINDER

Disassembly – 1) With master cylinder removed from vehicle, drain brake fluid from reservoir and mount cylinder in a soft jaw vise. Remove retaining pins and separate reservoir from master cylinder, then remove rubber seals from reservoir mounting holes in cylinder.

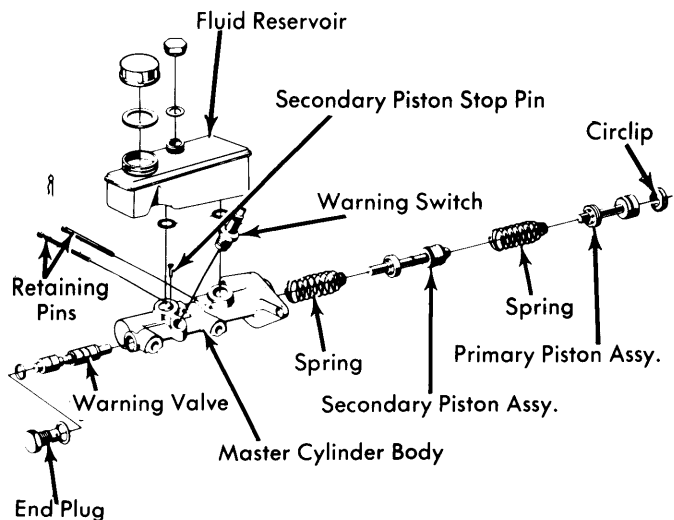

Fig. 6 Master Cylinder Reservoir, Housing and Pistons

2) Push in on primary piston and pull secondary piston stop pin from forward reservoir mounting hole. Remove circlip and take out primary piston assembly and spring. Remove cylinder from vise and carefully knock it against a block of wood to remove secondary piston assembly and spring. Remove brake warning switch from master cylinder, then remove end plug and lift out warning valve assembly.

Cleaning & Inspection – Wash all parts in clean brake fluid and dry with a clean, lint-free cloth. Inspect all parts for wear, damage or corrosion and replace as necessary. **NOTE** – Manufacturer recommends replacing all rubber parts whenever master cylinder is disassembled.

Brakes

SAAB (Cont.)

Reassembly — Reverse disassembly procedure and note the following: Coat all parts with clean brake fluid prior to reassembly. Use care when installing piston assemblies to prevent damage to seals.

POWER BRAKE UNIT

NOTE — Power brake unit is serviced as a complete assembly only. Do not attempt to overhaul.

DISC BRAKE ROTOR SPECIFICATIONS						
Application	Disc Diameter In. (mm)	Lateral Runout In. (mm)	Parallelism In. (mm)	Original Thickness In. (mm)	Minimum Refinish Thickness In. (mm)	Discard Thickness In. (mm)
Model 99						
Front	11.024 (280)	.004 (.10)500 (12.7)	.461 (11.7)	.460 (11.6)
Rear	10.614 (269.5)	.004 (.10)413 (10.5)	.374 (9.5)	.373 (9.4)