

## MGB

MGB

### DESCRIPTION

Lockheed type brake system consists of a tandem type master cylinder, self-adjusting disc brakes, manually adjusted leading-trailing type drum rear brakes, and a lever operated parking brake. Front brakes are of rotating disc and rigid mounted caliper type. Each caliper carries two disc pad assemblies, one on each side of the rotating disc. Rear brakes are internal expanding, shoe and drum type. Rear brakes are operated by a single wheel cylinder which is hydraulically actuated by a foot pedal. A brake pressure warning switch is mounted to master cylinder and connected to a warning light on instrument panel.

### ADJUSTMENT

#### DISC BRAKES

Disc brakes are self-adjusting, therefore no adjustment in service is required.

#### DRUM BRAKES

Raise and support rear of vehicle and fully release parking brake. Turn shoe adjuster clockwise until wheel is locked. Back off adjuster until wheel is free to rotate without binding.

**NOTE** — Adjustment on drum brakes also tightens up parking brake.

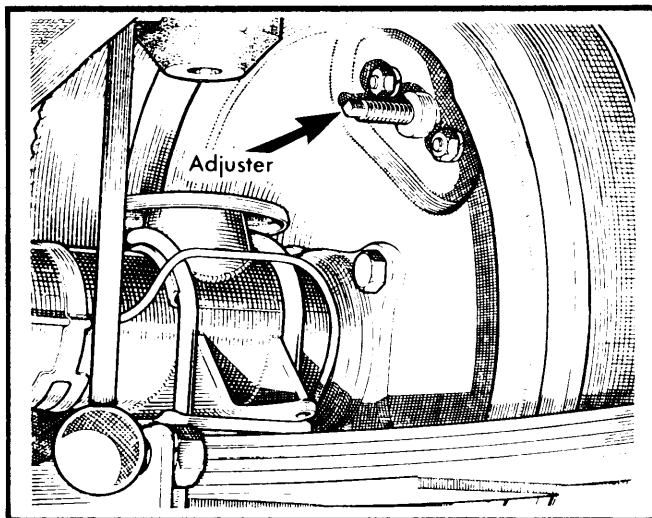

Fig. 1 Rear Drum Brake Shoe Adjuster Location

#### PARKING BRAKE

With service brakes properly adjusted, check for excessive parking brake cable stretch. Turn brass cable adjuster nut until total parking brake lever travel required to fully set parking brake is three to four serrations.

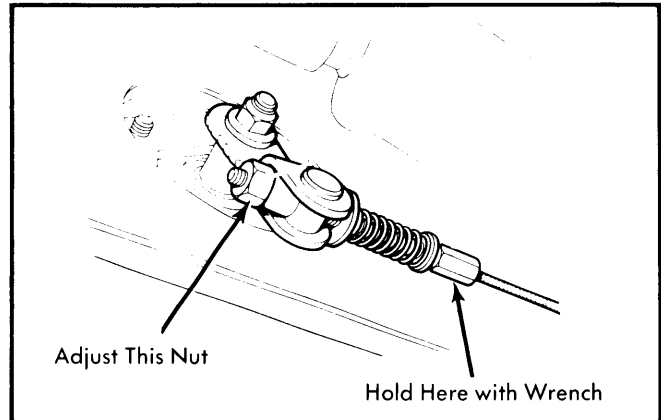

Fig. 2 Parking Brake Cable Adjustment Location

#### BRAKE SYSTEM BLEEDING

- 1) Release parking brake. Disconnect electrical wiring from brake failure switch. Unscrew switch about  $3\frac{1}{2}$  turns to ensure switch plunger is clear.
- 2) Fit bleed tube to caliper nearest master cylinder. Submerge opposite end of tube into a container partially filled with brake fluid. Open bleed screw about  $\frac{1}{2}$  turn.
- 3) Depress pedal rapidly through several full strokes allowing pedal to return unassisted. Repeat procedure (pedal pumping) with short pauses between each full stroke. Continue until all air bubbles stop. Tighten bleed screw with pedal on down stroke.
- 4) Repeat above procedure on other front caliper and each rear wheel cylinder. Tighten brake failure switch and connect wiring. If warning light remains on with parking brake released and pedal applied, repeat bleeding procedure.

### REMOVAL & INSTALLATION

#### FRONT DISC BRAKE PADS

**Removal** — Raise vehicle and remove tire and wheel. Depress pad retaining springs and remove cotter pins with retaining springs. Carefully lift out pads from caliper. Measure pad lining and replace if lining is worn to .063" (1.59 mm).

**Installation** — Before inserting disc pads, clean any foreign material from piston head and caliper cavity. Using suitable clamp, seat piston in cylinder bore. **NOTE** — During this operation fluid level will rise. Ensure machined portion of piston face is correctly positioned at inner end of caliper. Insert friction pads, reposition retaining springs and fit cotter pins. Check that pads have some degree of movement in caliper. It is acceptable to file high spots from friction pads if necessary. Pump brake pedal several times to readjust pistons.

#### REAR BRAKE SHOES

**Removal** — 1) Raise and support rear of vehicle. Remove wheel. Release parking brake. Loosen brake shoe adjuster. Remove screws and pull off brake drum.

# Brakes

## MGB (Cont.)

2) Make note of how springs at wheel cylinder end attach. Separate parking brake lever spring. Remove each brake shoe mounting pin, retainer, and spring. Pry (by spreading return springs) brake shoes out of adjuster and wheel cylinder. Lift off shoes. If necessary, wheel cylinder and parking brake mechanism can now be removed.

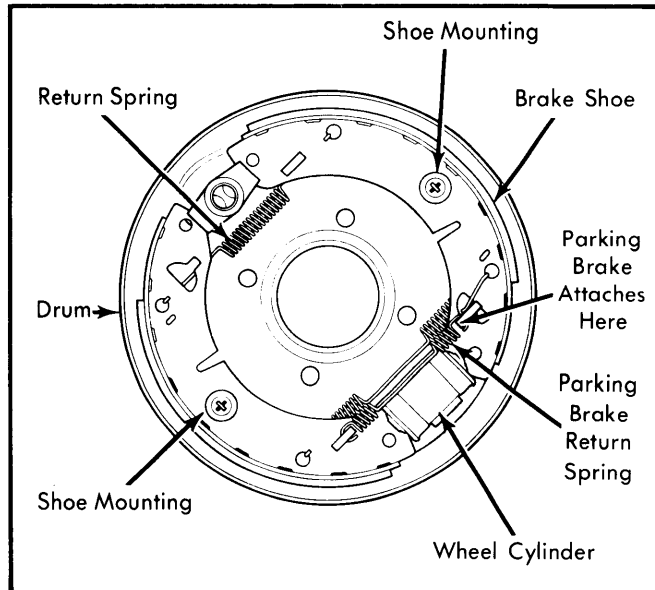

**Fig. 3 Installed View of Rear Brake Drum Assembly**

**Installation** — To install, reverse removal procedure and note: Apply suitable brake grease to shoe contact points. Adjust brake shoes.

### BRAKE CALIPER

**Removal** — Raise vehicle and remove tire, wheel, and friction pads. Drain fluid through bleed screw. Disconnect fluid hoses on mounting half of caliper and plug end of hose. Bend locking ears and withdraw mounting bolts. Lift off caliper.

**Installation** — To install, reverse removal procedure noting the following: Torque mounting bolts to 43 ft. lbs. (6.0 mkg).

### MASTER CYLINDER

**Removal** — After removing pedal box cover drain fluid from master cylinder reservoir. Disconnect hydraulic lines from master cylinder and separate electrical connections from warning switch. Move two nuts mounting master cylinder to power brake unit, then remove cylinder.

**Installation** — To install, reverse removal procedure. Start hydraulic lines before tightening master cylinder. Bleed hydraulic system and adjust brakes, if necessary.

### WHEEL CYLINDER

**Removal** — Remove rear brake shoes as previously outlined. Disconnect wheel cylinder fluid line. Pull line clear of cylinder and plug opening. Remove bleed screw. Pry out spring clip holding wheel cylinder to back plate. Slide out wheel cylinder.

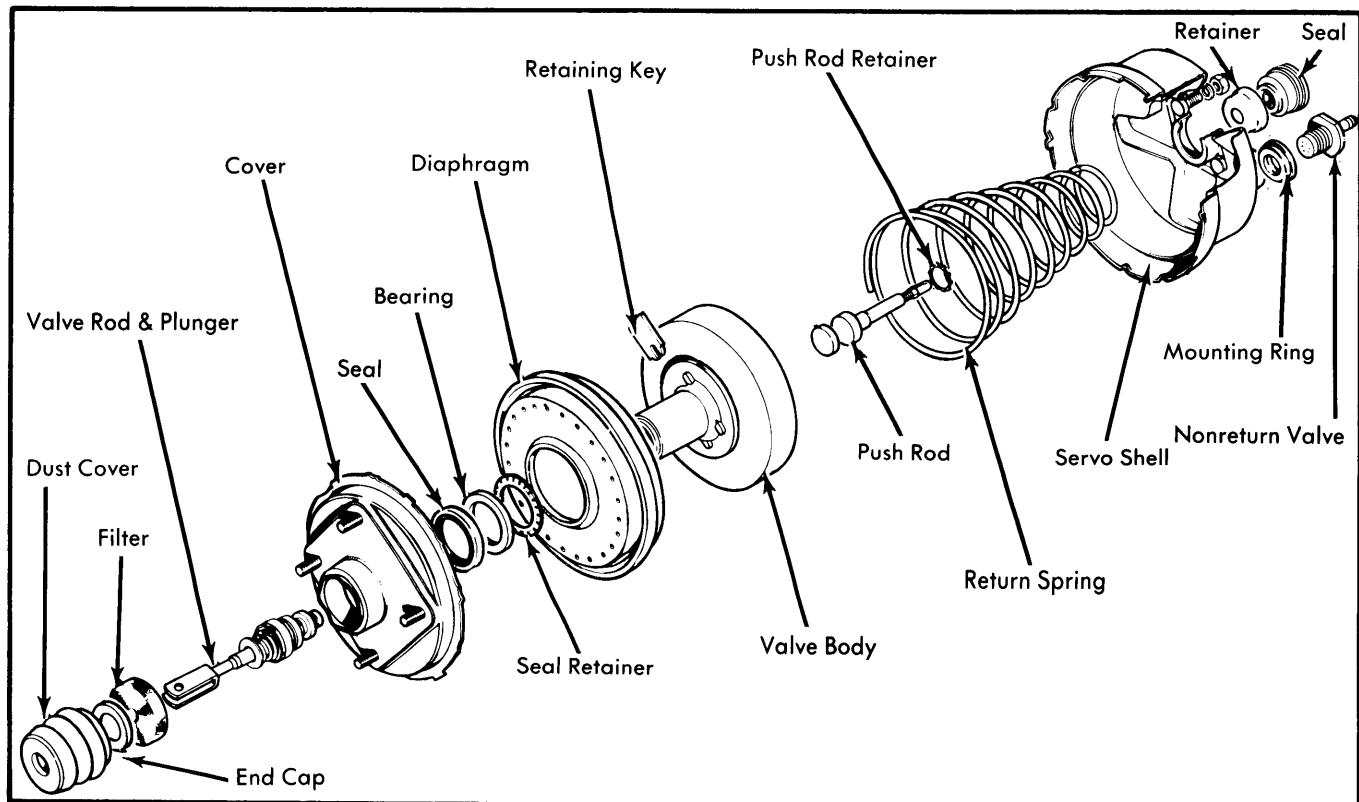

**Fig. 4 Power Brake Unit Components**

## MGB (Cont.)

**Installation** — Coat face of wheel cylinder with heat resistant grease. Slide wheel cylinder through back plate and install new spring clip. Insert bleed screw. Reconnect brake line. To install remaining components, reverse removal procedure.

### POWER BRAKE UNIT

**Removal** — Disconnect throttle return spring from air cleaner, then remove air cleaner from vehicle. Remove pedal box cover. Disconnect hydraulic lines from mounting clips. Separate master cylinder from power brake unit and support cylinder out of way. Disconnect vacuum source and pedal return spring, then remove pin securing pedal to push rod. Remove nuts and spring washers mounting power brake unit to pedal box and lift out unit.

**Installation** — To install, reverse removal procedure and bleed hydraulic system.

## OVERHAUL

### BRAKE CALIPER

**Disassembly** — 1) Remove brake caliper, leaving inlet hose connected. Clamp piston in mounting half of caliper and gently apply service brakes. This procedure will force rim half piston out enough to be removed by hand.

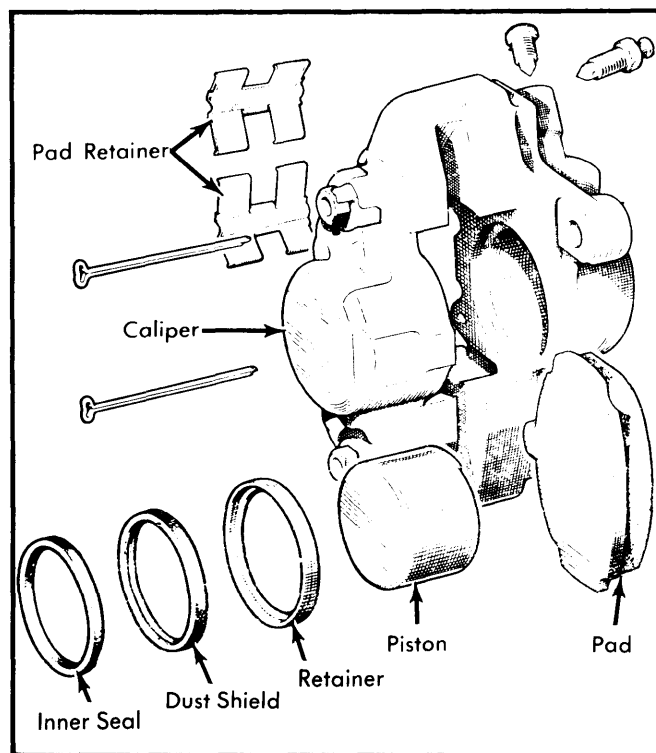

Fig. 5 Exploded View of Brake Caliper

2) Using a blunt instrument, remove fluid seal, taking care not to damage bore or retaining groove. To remove dust seal, insert a screwdriver between retainer and seal, and gently pry retainer from mouth of caliper bore. Disassembly procedure is same for mounting half. **NOTE** — Caliper rim half must be reassembled before disassembling mounting half.

**Reassembly** — 1) Coat new seal with brake fluid and ease seal into groove. Loosen bleed screw in rim half one turn. Coat piston with brake fluid and locate piston squarely in cylinder bore with cut-away portion facing inner edge of caliper.

2) Press piston down until  $5/16$ " protrudes from bore. Fit dust seal into retainer. Position seal assembly on extended portion of piston with seal innermost. Seat piston and seal assembly with clamp and retighten bleed screw. Rim half of caliper is reassembled in same manner.

### POWER BRAKE UNIT

**Disassembly** — Remove seal and retainer from servo (power brake unit). Fix servo into a vice and mark both cover and shell. Remove dust cover and pull out filter. Remove end cover by pressing down and turning counterclockwise. **NOTE** — Cover is under spring tension. Remove seal retainer, bearing, and seal from cover. Remove diaphragm from valve body. Push in on valve rod and plunger to release retaining key. Remove remaining components.

**Inspection** — Clean all components in brake fluid. Examine components for damage and wear. Replace all retainers and rubber parts. Valve rod and plunger must be replaced as an assembly.

**Reassembly** — To reassemble, reverse disassembly procedure and note the following: Coat all rubber components with brake fluid. Ensure push rod protrusion from servo is  $.400$ " (10.16 mm). One turn on adjuster alters rod length  $.035$ " (.088 mm).

### WHEEL CYLINDER

**Disassembly** — Pry off dust seals from each end of wheel cylinder. Slide pistons out. Remove seals taking care not to damage the seal groove.

**Inspection** — Clean all components in alcohol and allow to dry. If cylinder bore shows any signs of scoring or roughness, replace wheel cylinder.

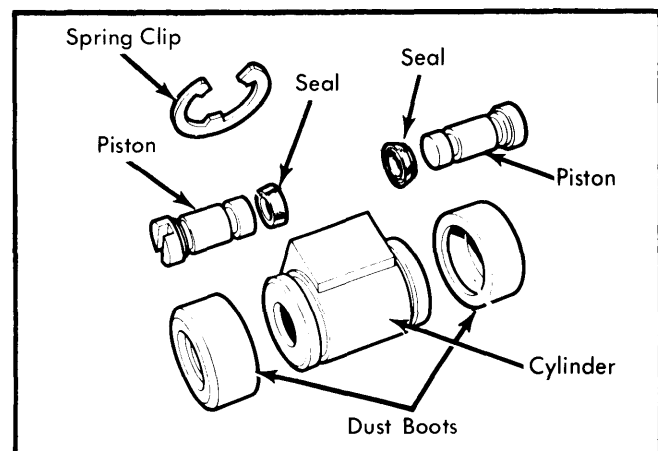

Fig. 6 Exploded View of Rear Wheel Cylinder

## MGB (Cont.)

**Reassembly** - Lightly coat all internal components with brake fluid. Slide in each seal with flat surface toward slotted end of piston. Push piston into bore. Pull seal over end of assembly.

### MASTER CYLINDER

**Disassembly** - 1) Remove brake pressure failure switch. Place cylinder in vice and remove reservoir. Take out seal and adaptor assembly from primary feed port, then remove secondary port seal. Extract spring clip from cylinder bore and take out primary piston, return spring, and cup.

2) Insert a rod into bore and depress secondary piston, take out stop plug from secondary feed port and withdraw secondary piston assembly. Remove pressure differential piston assembly. Pull rubber seals from pistons.

**Inspection** - Clean all components in brake fluid. Examine cylinder bore for scoring or ridges, replace components as necessary.

**Reassembly** - 1) Lubricate all components with brake fluid. Fit "O" ring seals to pressure warning piston. Place a shim on primary and secondary pistons. Install seal to both pistons, lip

facing away from shim. Fit the thinner of remaining seals to secondary piston with lips toward primary seat. Fit the secondary seal to primary piston with lip toward first seal. Fit return spring and cup to secondary piston and insert assembly.

2) Depress secondary piston and insert stop plug when piston head has passed feed port. Fit return spring and cup to primary piston and insert assembly. Refit spring clip.

3) Reinstall pressure differential valve into its bore and fit end plug. Fit "O" ring and seal to primary feed port adaptor and install into port recess. Install secondary feed port seal, round edge first. Reposition reservoir and brake pressure switch.

### TIGHTENING SPECIFICATIONS

Application	Ft. Lbs. (mkg)
Caliper Mounting Bolts .....	43 (6.0)
Master Cylinder End Plug.....	33 (4.5)
Master Cylinder Reservoir Screws .....	5 (.70)
Brake Hub-to-Rotor.....	43 (6.0)

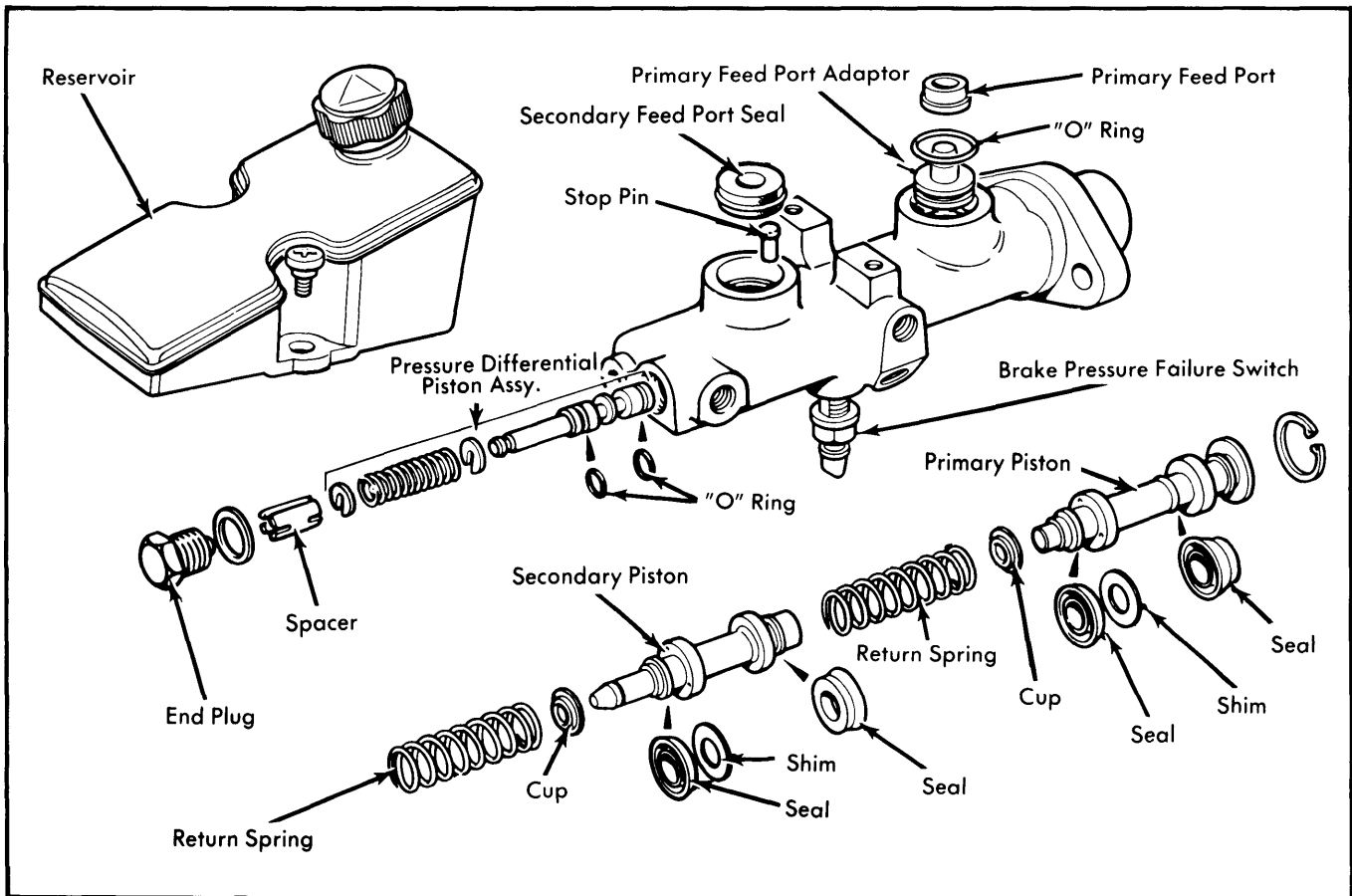

Fig. 7 Master Cylinder Reservoir, Body and Piston Assemblies