

## LUV

LUV

### DESCRIPTION

Brake system is hydraulically actuated using a tandem master cylinder and a Master Vac power brake unit. Front brakes are single piston, floating disc type. Rear brakes are leading-trailing, shoe/drum type. Drum brakes are actuated by dual piston wheel cylinder. Parking brake is cable and lever operated, actuating shoes of rear drum.

### ADJUSTMENT

#### PEDAL HEIGHT

Pedal height, measured from top of pedal pad to floor, should be 5.9-6.3". If adjustment is required, disconnect battery ground cable and stop lamp switch wiring harness. Remove stop lamp switch from bracket, then rotate master cylinder push rod until proper pedal height is obtained. Install stop lamp switch, then adjust clearance between switch housing (not actuating pin) and brake pedal tab to .02-.04". Tighten lock nuts and connect stop lamp switch wiring harness.

#### FRONT DISC BRAKE PADS

Disc brakes are self-adjusting

#### REAR BRAKE SHOES

Rear brakes have a self-adjusting mechanism. No in-service adjustment is required. Initial adjustment may be necessary after changing brake lining. Pull adjuster mechanism out of star. Rotate star until shoes just contact drum. Final adjustment will be accomplished with self-adjuster mechanism.

#### PARKING BRAKE

Apply parking brake two notches from fully released position. Loosen equalizer check nut and adjust front jam nut until a light to moderate drag is felt when rear wheels are rotated

forward. Tighten nuts securely, release parking brake lever, and ensure no drag is present.

#### HYDRAULIC SYSTEM BLEEDING

**NOTE** — Make sure engine is running while bleeding brakes. This will prevent damage to push rod.

Attach a bleed tube to wheel cylinder bleeder screw and immerse opposite end of tube in a container partially filled with brake fluid. Open bleeder screw  $\frac{3}{4}$  turn, depress pedal, close bleeder screw before bottom of pedal stroke, and allow pedal to return slowly. Continue operation until no air bubbles are seen in discharged fluid. Bleed wheel cylinder closest to master cylinder first, then repeat procedure at remaining cylinders, ending with cylinder furthest from master cylinder.

### REMOVAL & INSTALLATION

#### FRONT DISC BRAKE PADS & BRAKE CALIPER ASSEMBLY

**Removal** — Raise and support vehicle. Remove tire and wheel. Take out caliper pin stops and remove stops. Remove caliper off support, take out stop plates, then suspend caliper from frame with wire. Remove pads and shims. Mark pad location for reassembly, if necessary. Separate anti-rattle springs from support.

**Inspection** — Replace disc pads when thickness is reduced to .039" (1 mm). Always replace pads in axle sets. Check caliper, supports and adaptors for distortion or cracking. Inspect inside caliper cavity for leaks. Replace any parts found defective.

**Installation** — To install, reverse removal procedure and note the following: Original pads must be installed according to in-

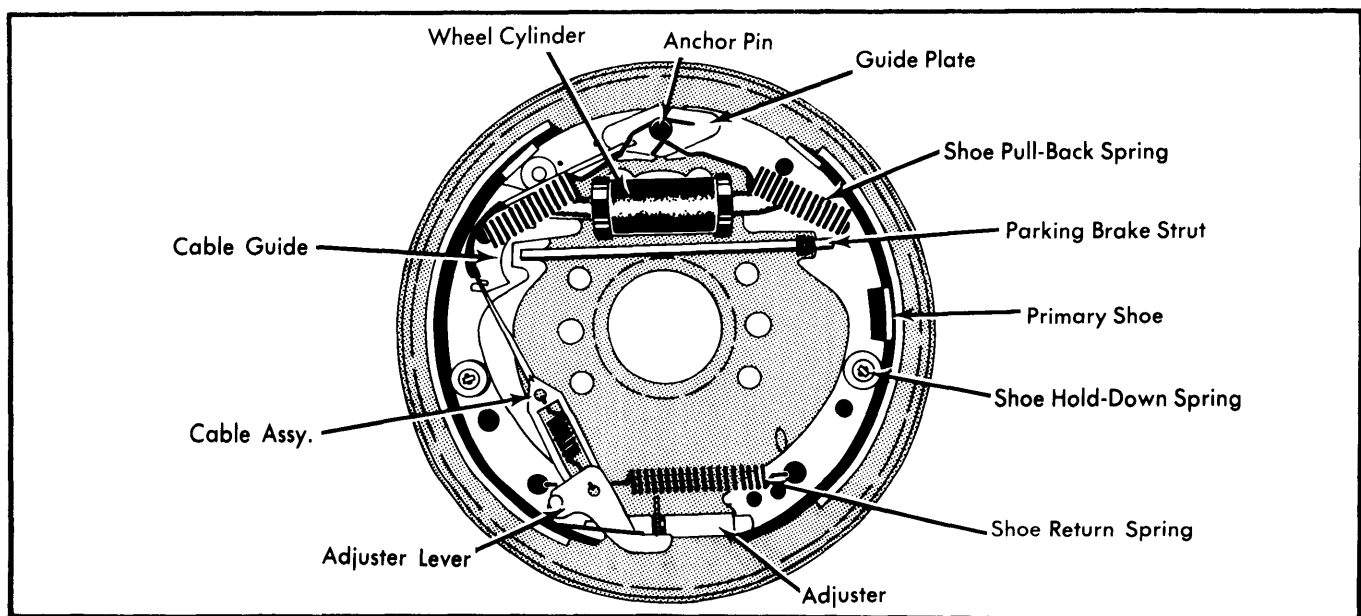

Fig. 1 Assembled View of Rear Drum Brake Assembly

## LUV (Cont.)

dex marks. Install pads to supports with wear indicators facing LOWER SIDE. Make sure brake lubricant is applied to sliding portion of caliper.

## FRONT DISC BRAKE ROTOR

**Removal** — Raise and support vehicle. Remove tire and wheel. Remove caliper assembly. Remove grease cap, nut, and outer bearing. Pull hub and rotor assembly from vehicle. It is not necessary to separate hub and rotor, except to replace either component.

**Inspection** — Adjust all play out of wheel bearings and inspect rotor runout using a dial gauge. If runout exceeds .005" (.13 mm), replace or resurface. Check parallelism at four or more points. Value obtained must not exceed .0005" (.001 mm) in 360°. Make all measurements at same distance from edge of rotor.

**Installation** — To install, reverse removal procedure and note the following: Adjust wheel bearings. See *Wheel Bearing Adjustment* in WHEEL ALIGNMENT Section.

## REAR BRAKE SHOES

**Removal** — Remove tire and wheel. Remove tension from parking brake cable, remove retaining screws and remove brake drum. **NOTE** — Mark drum for reassembly reference. Remove return springs, hold-down springs, and self-adjuster assembly. Separate primary and secondary brake shoes, adjuster mechanism, return spring, and parking brake strut.

Separate parking brake lever and rear cable, and remove lever from secondary shoe.

**Installation** — Install parking brake lever to secondary shoe and rear cable to lever. Connect brake shoes together with return spring, and place adjuster screw into position, making sure star wheel is nearest secondary shoe. Install parking brake strut with spring on primary shoe end, then fit shoes to wheel cylinder push rods. Install hold-down springs, self-adjuster assembly, and return springs.

## WHEEL CYLINDER

**Removal** — With brake drum removed, disconnect brake shoe return springs. Disconnect hydraulic line and bolts retaining cylinder to backing plate. Disengage cylinder push rod(s) from brake shoe(s) and remove cylinder.

**Installation** — Reverse removal procedure and bleed hydraulic system.

## MASTER CYLINDER

**Removal** — Disconnect battery ground cable. Disconnect hydraulic lines at master cylinder and cover ends to prevent entry of dirt. Remove bracket bolt at front end of cylinder, and nuts retaining cylinder to power unit, then remove master cylinder and gasket from power unit.

**Installation** — Reverse removal procedure, bleed hydraulic system and adjust pedal height if necessary.

## POWER BRAKE UNIT

**Removal** — Disconnect battery ground cable. Disconnect hydraulic lines at master cylinder and cover ends to prevent entry of dirt. Remove bolts attaching bracket to master cylinder and fender and remove bracket. Disconnect vacuum line at power unit and place out of way. Disconnect brake pedal return spring and push rod. Remove nuts attaching power unit to firewall, and remove power unit and master cylinder as an assembly.

**Installation** — Reverse removal procedure, bleed hydraulic system, and adjust pedal height if necessary.

## OVERHAUL

## FRONT DISC BRAKE CALIPER

**Disassembly** — Remove flex hose from caliper. Using pointed, but blunt instrument, remove seal from caliper. Place a block of wood between piston and caliper cavity wall, then apply enough compressed air pressure to force piston from cylinder. Remove and discard piston ring seal.

**Inspection** — Replace dust seal and piston seal. Check cylinder bore for wear, scuffing or corrosion. Inspect cylinder piston for damage or wear. Never attempt to refinish piston. Replace any parts found defective.

**Assembly** — Lubricate piston seal and insert into caliper bore. Carefully insert piston into caliper assembly. Install dust seal to piston and caliper. Fit seal ring into dust seal.

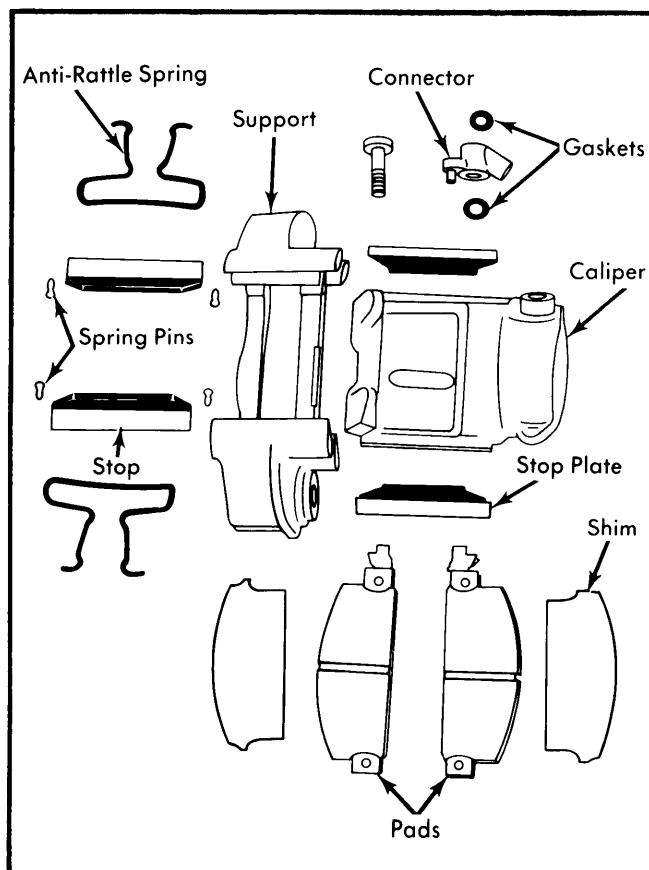

Fig. 2 Exploded View of Front Disc Brake Assy.

## LUV (Cont.)

### WHEEL CYLINDER

**Disassembly** — Remove boots from cylinder ends. Remove pistons and cups. Remove expander springs, if equipped.

**NOTE** — Front wheel cylinder pistons and cups are serviced as an assembly.

**Cleaning & Inspection** — Clean all parts in clean brake fluid. **NOTE** — Do not use mineral based solvents. Inspect cylinder bore and pistons for rust, corrosion, or other damage; replace parts or cylinder as necessary. Measure clearance between piston and cylinder bore; if clearance exceeds .006", replace wheel cylinder assembly.

**Reassembly** — Lubricate cylinder bore with clean brake fluid. Install spring expander into bore, then install new cups with flat surfaces toward outside. Install new pistons into cylinder with flat surfaces toward inside. **NOTE** — Do not lubricate pistons or cups before installation. Press new boots onto cylinder.

### MASTER CYLINDER

**Disassembly** — Remove reservoir caps, plates and strainers and drain brake fluid. Place cylinder in a vise and remove reservoirs. Remove connector bolt, connector and gaskets from rear outlet, then withdraw end plug, gasket, check valve, return spring and spring seat. Remove check valve assembly from front outlet. Push in on primary piston, remove stop bolt and snap ring, and remove primary and secondary piston assemblies.

**Cleaning & Inspection** — Wash all parts in clean brake fluid and dry using compressed air. Blow out all passages, orifices and valve holes. If slight rust is found, polish clean with crocus cloth or emery paper. Inspect cylinder bore for scoring,

pitting, or other damage. Check clearance between pistons and cylinder bore; if greater than .006", replace cylinder.

**NOTE** — Manufacturer recommends replacing rubber parts whenever master cylinder has been disassembled.

**Reassembly** — Lubricate cylinder bore and all parts with clean brake fluid, reverse disassembly procedure, and note the following: Use all new gaskets and seals when reassembling. When reassembly is complete, bench bleed master cylinder as follows: Install plugs in all outlet ports of cylinder, fill reservoirs with clean brake fluid, and press in and out on primary piston until air bubbles are no longer seen in fluid.

### POWER BRAKE UNIT

**Disassembly** — 1) Remove master cylinder reservoir and drain remaining brake fluid from cylinder. Scribe alignment marks on front and rear shells to assure reassembly in original position. Clamp flange of master cylinder in a vise with power unit up. Loosen push rod clevis lock nut and remove clevis and lock nut, then remove push rod boot.

2) Place suitable wrench (J-9504) over rear shell mounting studs. Press down on wrench while rotating counterclockwise and remove rear shell, piston rod, power piston, return spring and spring retainer. Remove nuts and lock washers and separate master cylinder and power unit front shell, then remove and discard gasket.

3) Pry retainer off power piston and remove air silencer and filter, then remove rubber diaphragm from piston. Rotate power piston until push rod retainer slot is down, then press in on rod, allowing retainer to fall out of power piston. Remove push rod assembly and reaction disc. **NOTE** — Do not disassemble push rod assembly; if defective, replace complete assembly.

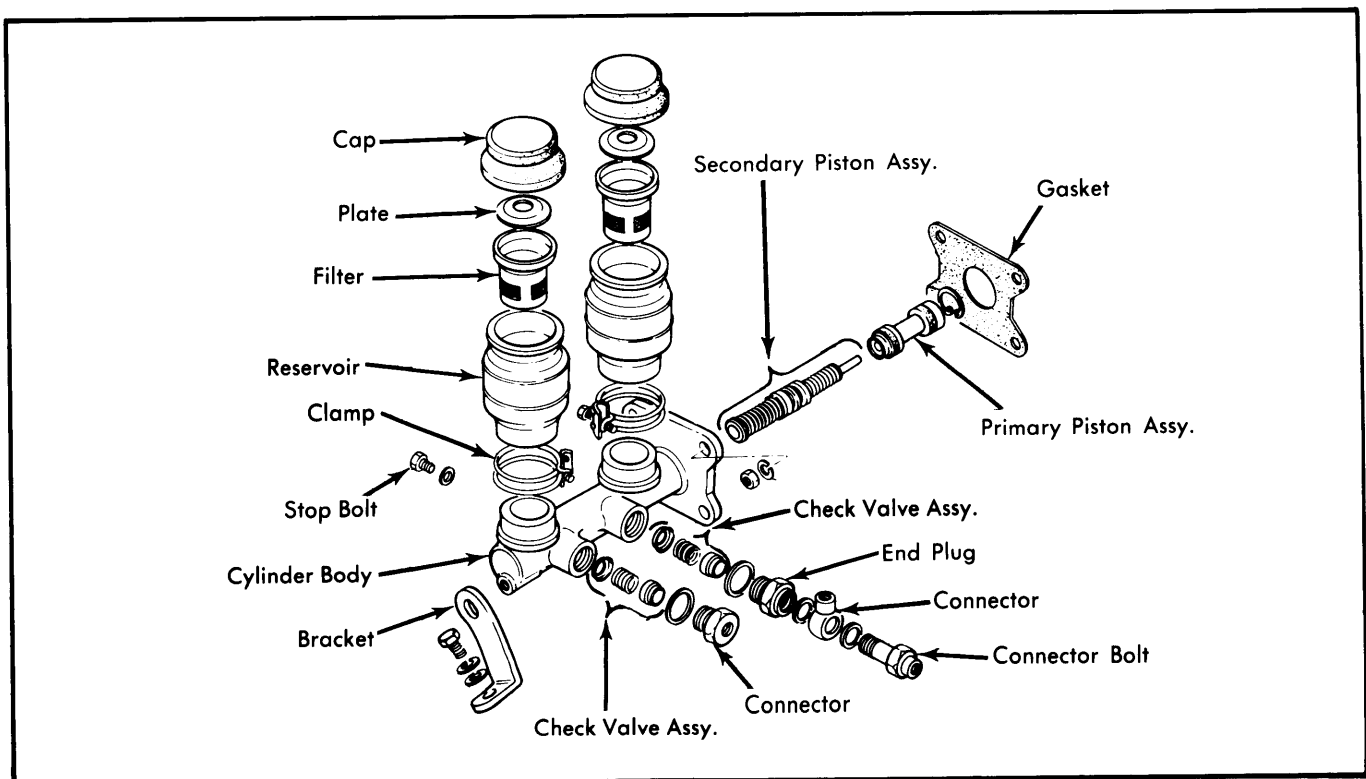

Fig. 3 Master Cylinder Reservoir, Body and Piston Assembly

# Brakes

## LUV (Cont.)

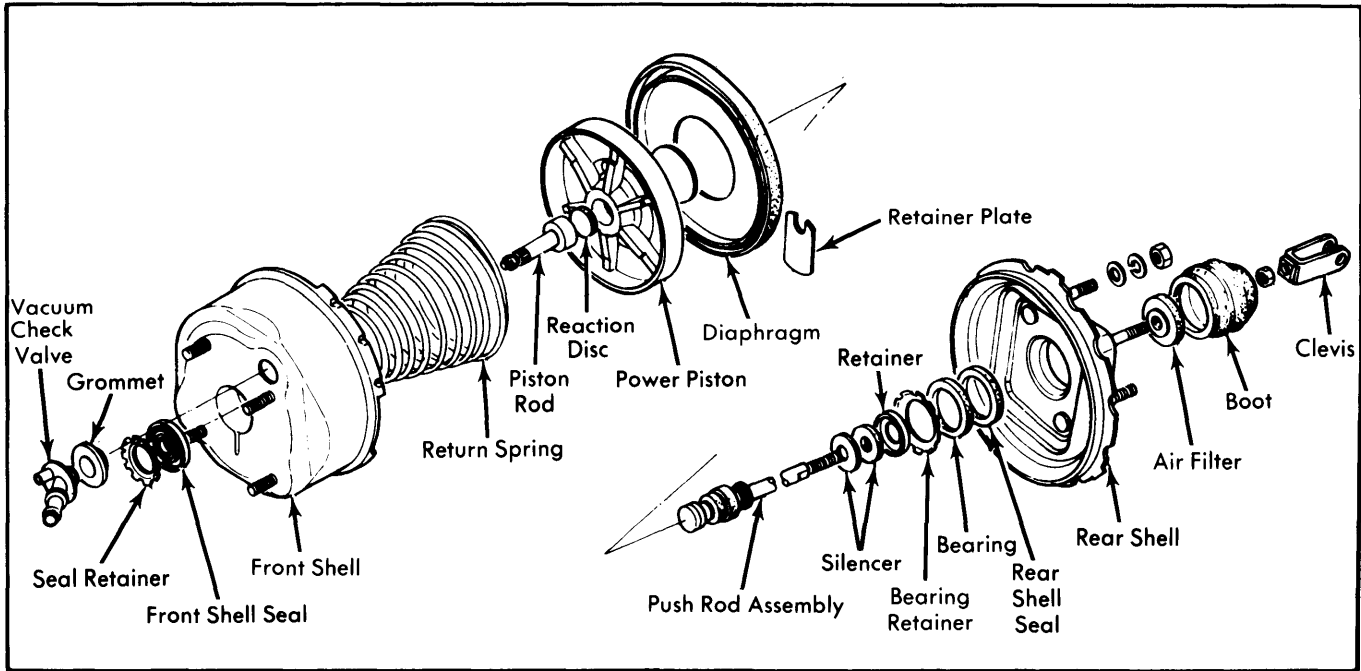

Fig. 4 Exploded View of Power Brake Assembly

4) If rear shell is defective, pry out seal retainer and remove spacer and seal assembly. If front seal is defective, pry out retainer and remove seal. If vacuum check valve is defective, remove using a twisting motion, then remove grommet.

fine emery cloth. Inspect all parts for cracks, nicks, distortion or other damage and replace as necessary.

**Cleaning & Inspection** — Clean all parts in denatured alcohol and blow dry with compressed air. **NOTE** — Do not clean parts with a mineral based solvent. Inspect inside surface of front and rear shell for wear or damage. If slight rust is found on inside surface, polish clean with crocus cloth or

**Reassembly** — Reverse disassembly procedure and note the following: Apply a coat of silicone grease to parts before installation. When assembling front shell to rear shell, ensure marks made at disassembly are aligned. When reassembly is completed, remove master cylinder from power unit. Place suitable gauge (J-24568) over piston rod so that legs rest on master cylinder mounting surface. Piston rod should touch cut-out portion of gauge. If rod must be adjusted, hold rod at serrated portion and turn threaded end. **NOTE** — Push rod must be bottomed in power unit before making adjustment.

### DISC BRAKE ROTOR SPECIFICATIONS

Application	Disc Diameter In. (mm)	Lateral Runout In. (mm)	Parallelism In. (mm)	Original Thickness In. (mm)	Minimum Refinish Thickness In. (mm)	Discard Thickness In. (mm)
LUV	.....	.005 (.13)	.0005 (.013)	.709 (18.0)	.668 (16.97)	.653 (16.6)

### BRAKE SYSTEM SPECIFICATIONS

Application	Drum Diam. In. (mm)	Wheel Cylinder Diameter		Master Cylinder
		Front In. (mm)	Rear In. (mm)	Diameter In. (mm)
LUV	10 (254)	1.06 (26.9)	.75 (19.0)	.875 (22.2)

## LUV (Cont.)

BRAKE DRUM SPECIFICATIONS				
Application	Drum Diameter In. (mm)	Original Diameter In. (mm)	Maximum Refinish Diameter In. (mm)	Discard Diameter In. (mm)
LUV	10 (254)	10.000 (254)	10.059 (255)	10.079 (256)

TIGHTENING SPECIFICATIONS	
Application	Ft. Lbs. (mkg)
Backing Plate-to-Axle Housing .....	55 (7.7)
Wheel Cylinder .....	10 (1.4)
Master Cylinder	
End Plug .....	90 (12.4)
Connector Bolt .....	35 (4.8)
Stopper Bolt .....	14 (1.9)
Mounting Nuts .....	10 (1.4)
Power Brake Unit Mounting Nuts .....	10 (1.4)
Rotor-to-Hub .....	36 (5.0)
Caliper Connector .....	22 (3.0)
Support-to-Adaptor .....	64 (9.0)
Caliper Assembly-to-Knuckle	
Large Bolt .....	55 (7.6)
Small Bolt .....	35 (4.8)