

VOLVO POWER-ASSISTED RACK & PINION

DESCRIPTION

Rack and pinion type cam gear power steering is standard on 260 models and on 240 station wagons. This power steering unit consists of a rack and pinion steering gear and a power assist pump interconnected by flexible lines. The 240 and 260 series use a Saginaw type pump with a separate fluid reservoir. The 240 series also uses a ZF type pump with a separate fluid reservoir.

GENERAL SERVICE

STEERING GEAR LUBRICANT

Type – Engine oil SAE 20W-40 or SAE 20W-50.

Capacity – 6¾ oz.

HYDRAULIC SYSTEM LUBRICANT

Type – ATF Type A or Dexron.

Capacity – 2.3 pts.

STEERING GEAR FILLING

Remove inner clamp on right side rubber bellows, and using a suction gun, fill gear with recommended lubricant through side of bellows. Reinstall clamp, then carefully compress bellows so some oil will flow to other side.

HYDRAULIC OIL FILLING AND BLEEDING

Fill the reservoir with approved oil, then start engine and allow to idle, adding oil as level drops. Turn steering wheel left and right lock to lock in a slow even motion to allow the pump to operate at low pressure. Continue turning steering wheel until oil in reservoir is almost free of air bubbles. Check that oil is at the level mark, then install reservoir cap.

SERVO BALANCE TESTING AND ADJUSTING

Testing – 1) Connect a pressure gauge as shown in Fig. 1). Make sure oil in reservoir is at level mark.

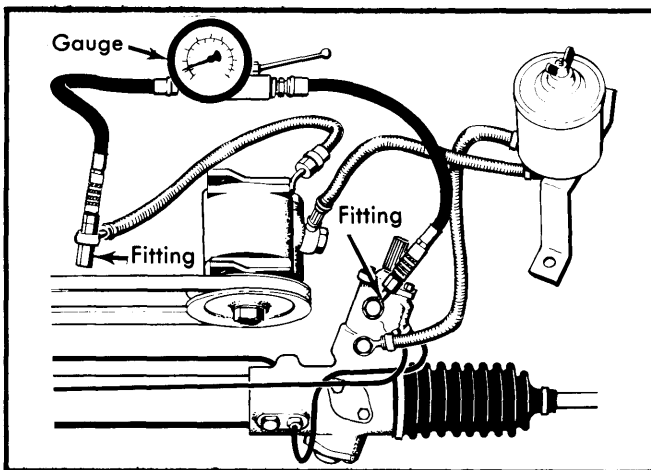

Fig. 1 Pressure Gauge Test Set Up

2) Remove steering wheel impact guard by compressing sides slightly. Install a torque wrench on steering wheel nut.

3) With engine at idle, turn steering wheel (using torque wrench) slowly to right and read torque the moment pressure reaches 170 psi (12 kg/cm²). Repeat operation turning steering wheel to left. Torque should be 30-40 INCH lbs. (35-46 cmkg) as pressure approaches 170 psi (12 kg/cm²). The difference between right and left sides may not exceed 8 INCH lbs. (9 cmkg).

4) If the difference between the sides exceeds this amount, use the following procedures for correction.

Adjusting – 1) Turn off engine and remove lock nut and lock washer from pinion lower bearing (See Fig. 2) Lock washer will have one tab bent down to lock adjustment nut (bearing race).

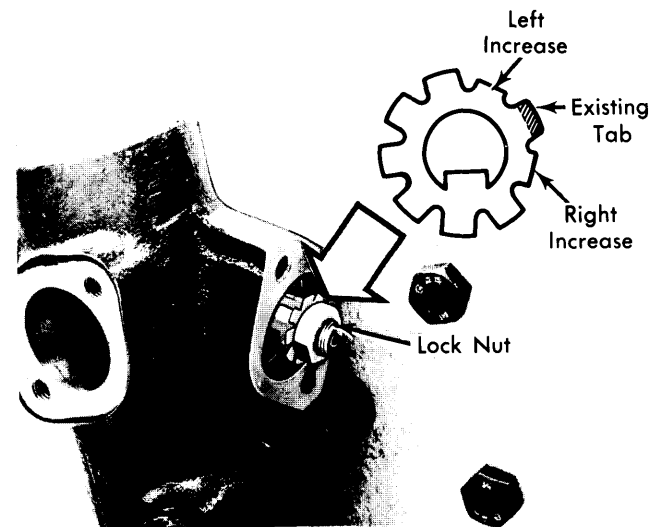

Fig. 2 Lock Washer Adjustment

2) To increase torque for left side, straighten existing bent tab and bend first tab to left. To increase torque for right side, bend first tab to right.

NOTE – Changing tabs increases torque for one side and decreases torque an equal amount the other side. The value of torque increase or decrease is 4 INCH lbs. (4.6 cmkg).

3) After bending tab, use suitable tool (9995049) to turn adjustment nut until groove fits lock washer tab. Reinstall lock washer and lock nut, then bend unused lock washer tab to lock nut. Install pinion cover and gasket.

PUMP PRESSURE TEST

1) – With pressure gauge connected as shown in Fig. 1, and engine at idle, turn steering wheel fully to left, then fully to right, pressing at end position for a maximum of 10 seconds. Correct pressure should be 895-995 psi (63-69 kg/cm²) for the Saginaw pump and 825 psi (58 kg/cm²) for the ZF pump.

2) To test system maximum pressure, close pressure gauge valve and block oil flow for maximum of 10 seconds. If pressure does not reach the values in the preceding paragraph, the pump is defective and must be repaired or replaced, see *Overhaul* in this article.

NOTE – The manufacturer does not recommend repair of the Saginaw pump, replace if defective.

VOLVO POWER-ASSISTED RACK & PINION (Cont.)

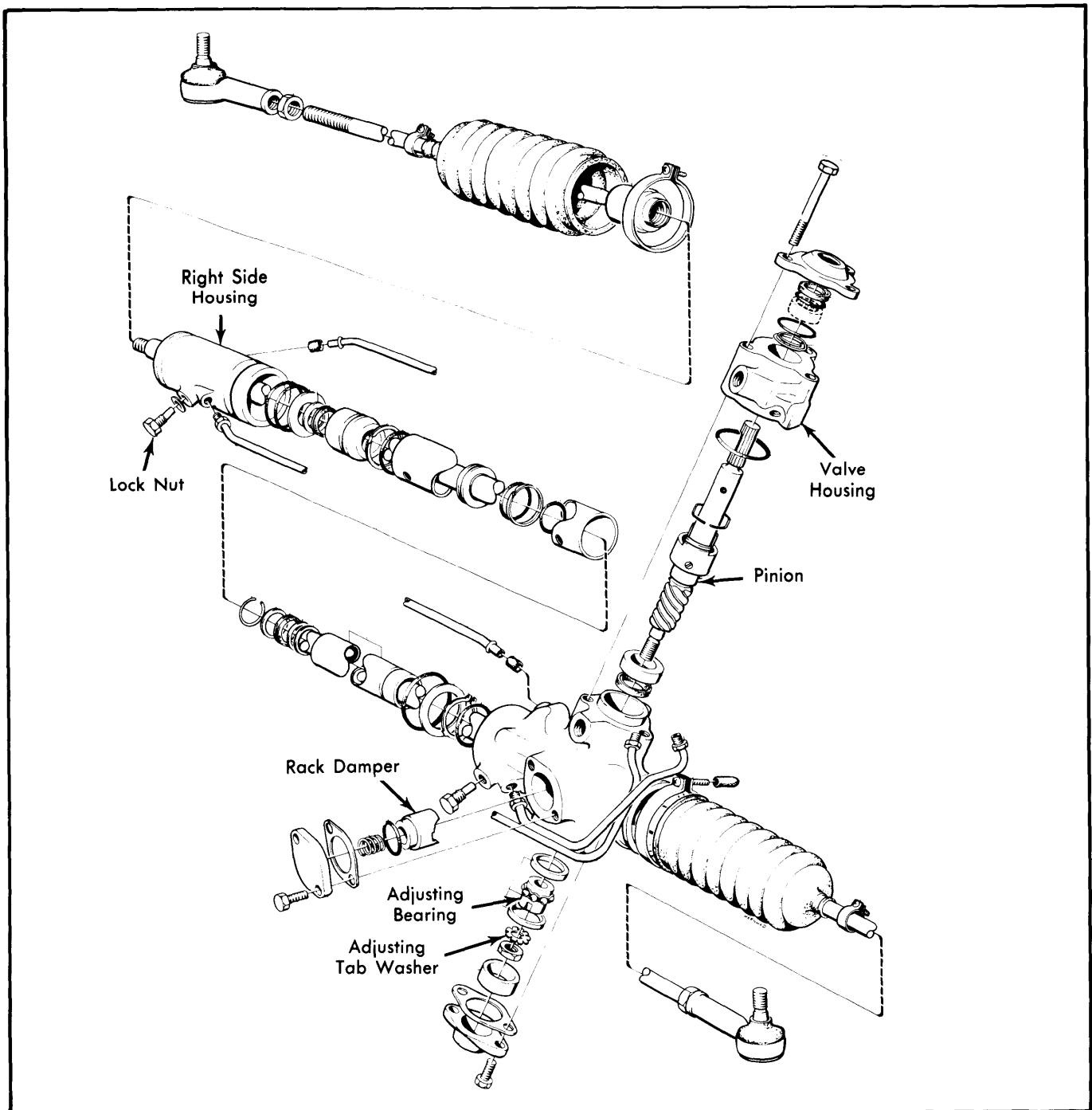

Fig. 3 Exploded View of Volvo Power Steering Components

REMOVAL & INSTALLATION

STEERING GEAR

Removal – 1) Remove lock bolt and nut from pinion flange. Bend flange apart slightly. Raise and support front of vehicle and remove wheels. Remove tie rod nuts and disconnect ball

studs from spindle using suitable ball joint removal tool (5043). Remove splash guard.

2) Disconnect hoses at steering gear and install plugs in hose connections to protect against contamination. Remove bolts securing steering gear to front axle member. Pull steering gear down until free of steering shaft flange, then remove steering gear on left side of vehicle.

Power Steering

VOLVO POWER-ASSISTED RACK & PINION (Cont.)

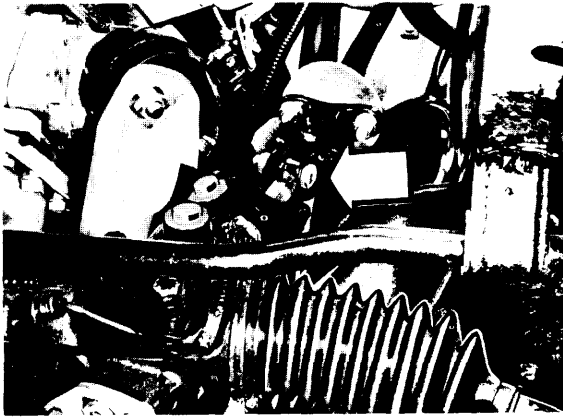

Fig. 4 Flange Lock Bolt

Installation — 1) To reinstall, reverse removal procedure, noting the following: Make sure recess on pinion shaft is aligned toward lock bolt opening in flange.

2) Install right side "U" bolt and flange, but do not tighten. Install and tighten left side bolts, then tighten right side "U" bolt.

3) Connect steering rods, making sure rods are same length. Difference should not exceed $\frac{1}{16}$ " (2 mm). Install lock bolt on flange and reconnect hoses.

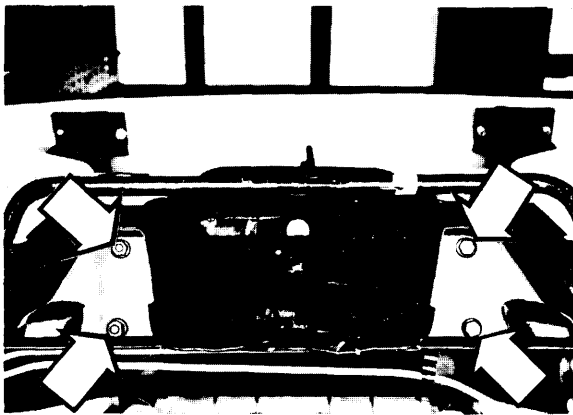

Fig. 5 Steering Gear Mounting Bolts

POWER STEERING PUMP (ZF)

Removal — Place a container below the pump to receive drain oil, then disconnect hydraulic connections. Remove nuts on two long bracket bolts and tensioner locking screws on both sides of pump. Remove drive belt.

2) Turn pump up and remove three screws retaining bracket to engine block, then remove pump and bracket.

Installation — 1) To reinstall, reverse removal procedures, noting the following: Use new copper washers when reconnecting pump hoses. Fill the system with new oil that meets specifications. See *GENERAL SERVICING* in this article.

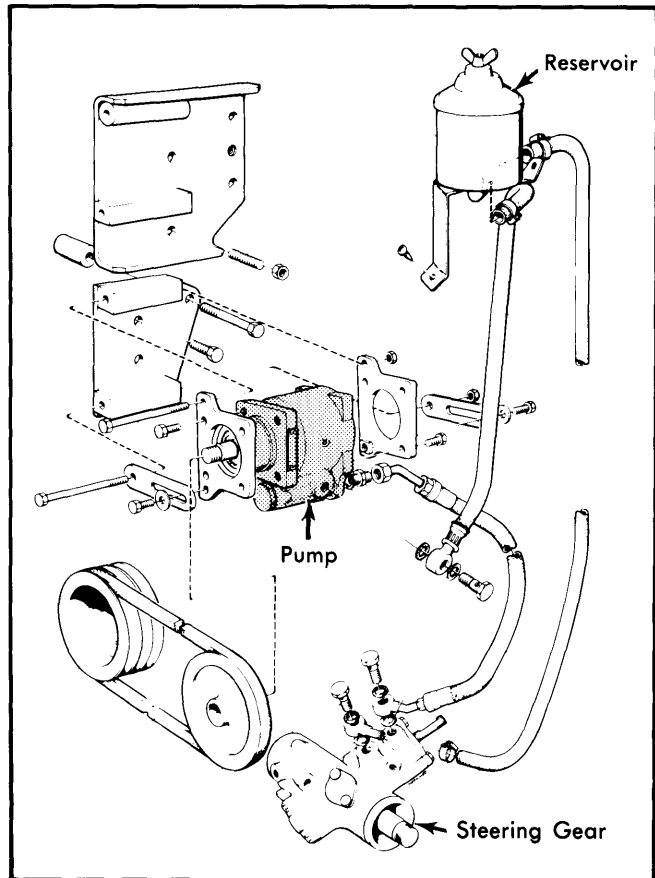

Fig. 6 ZF Power Steering Pump

POWER STEERING PUMP (SAGINAW)

Removal — Remove two pivot bolts on bracket and bolt on belt tensioning bracket. Place a container below pump to receive drain oil, disconnect hydraulic connections at pump, then remove pump.

Installation — To reinstall, reverse removal procedures, then fill and bleed the system, See *GENERAL SERVICING* in this article.

OVERHAUL

STEERING GEAR

Disassembly — 1) Clean steering gear exterior and check inner ball joints for wear. Loosen pinion side rubber bellows and drain oil. Remove steering rod using a 32 mm open end wrench, take load off of pinion with an adjustable wrench. When unscrewing steering rod, lock tab will bend up.

2) Remove oil lines, rack damper cover, piston, "O" ring, and spring. Remove pinion cover and spacer sleeve. Bend up locking tab and remove nut. Using tool (5049), unscrew inner bearing race with ball retainer and outer race from pinion.

VOLVO POWER-ASSISTED RACK & PINION (Cont.)

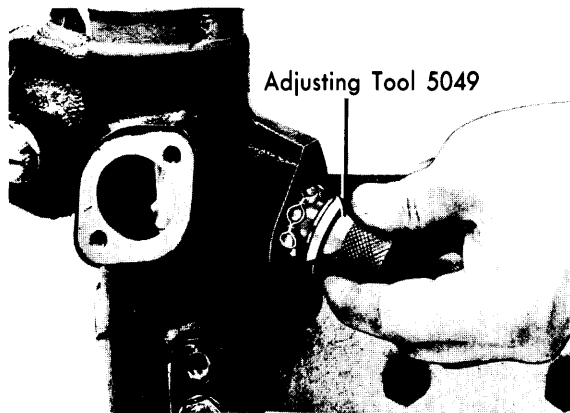

Fig. 7 Inner Bearing Race

3) Unscrew three screws from valve housing cover and remove cover and spring, then lift off valve housing and lift out pinion.

4) Unscrew right side housing lock bolt and remove housing and connecting tube from outer tube, then pull out rack and bearing sleeve. Remove bearing sleeve rack.

5) Unscrew left side housing lock bolt, then remove outer and inner tube from housing. Using suitable tool (1819) remove upper bushing from housing. Use two narrow screwdrivers and remove lower pinion bearing outer race.

CAUTION — Do not use tool (5051) to remove upper bushing.

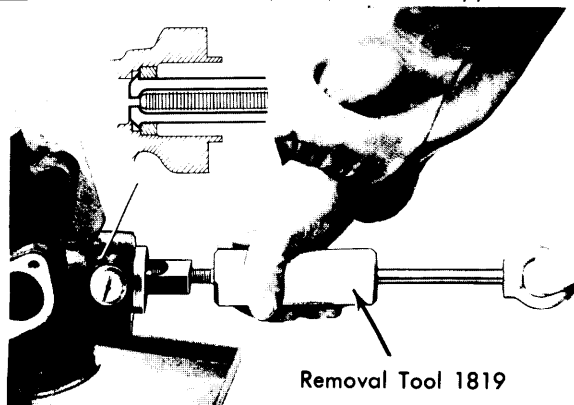

Fig. 8 Removing Upper Bushing

6) Remove "O" rings and spacer from right side housing. Use suitable tool (5051) to remove bearing and seal from valve housing cover. Remove "O" ring from cover and "O" ring, seal, and plastic rings from rack bearing sleeve.

7) Remove plastic ring and "O" ring from rack only if, damaged, worn or rack has more than 24,000 miles on vehicle. Remove oil seal from inner tube. Remove washer and snap ring from tube.

Reassembly — 1) Coat all parts with oil before reassembling. Replace all seals, "O" rings, and defective parts. Using tool (5050) install oil seal, bearing and "O" ring in valve cover. Seal should be glued into cover or cover and seal should be changed.

NOTE — If the rack bearing is replaced, the bearing sleeve should also be replaced.

2) Install plastic ring and "O" ring on rack bearing sleeve with "O" ring on tapered side of sleeve. Install snap ring on inner

tube, then install "O" ring and plastic ring on rack piston with the "O" ring under the plastic ring.

3) Assemble spacer sleeve, oil seal, and plastic ring on rack (from tooth side). Use tape over teeth to avoid damaging oil seal, then remove tape and install spacer sleeve on rack.

4) Insert seal in left side housing with lip facing out, then press in bushing using suitable tool. Install two "O" rings in left side housing, then install the two "O" rings and spacer washer in right side housing.

5) Lubricate end of inner tube and install with spacer into left housing, then push rack (with seal and spacer rings) into inner tube. Place tool (5056) on rack and using rack and tool, press seal and spacer rings into housing. Withdraw rack approximately $\frac{3}{4}$ " (20 mm) and remove tool, install lock ring.

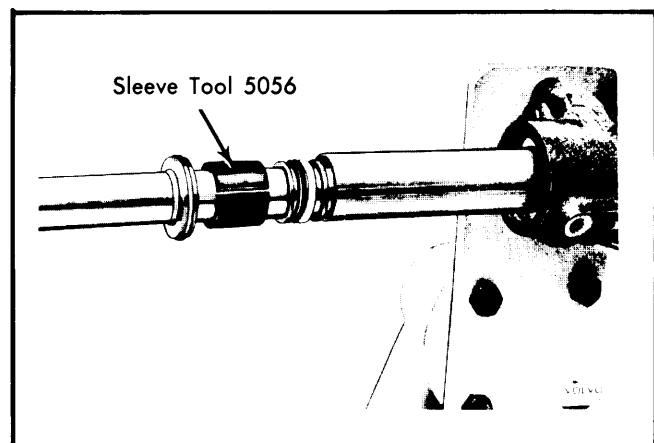

Fig. 9 Installing Seals & Spacer Rings

6) Insert outer tube in left housing, align lock bolt holes in housing and tube, lubricate tube and plastic seal on rack piston, then insert lock bolt with seal. Torque bolt to 9-12 ft. lbs. (1.24-1.66 mkg). Lubricate and insert bearing sleeve in outer tube.

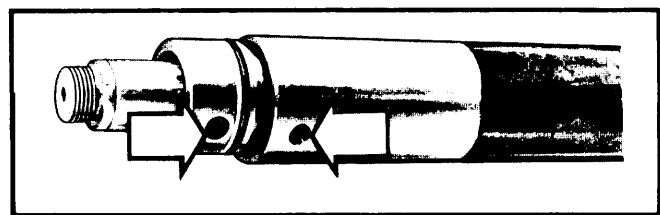

Fig. 10 Lock Bolt Hole Alignment

7) Align sleeve hole with outer tube hole, tape threaded edges and install seal. Remove tape and install plastic ring in bearing sleeve. Lubricate end of connecting tube and insert tube with rubber seal in right side of housing.

8) Install right housing with connecting tube and rubber seal. Align hole in right side of housing with hole in outer tube and install lock bolt. Torque bolt to 9-12 ft. lbs. (1.24-1.66 mkg).

9) Install upper race for pinion lower bearing and insert pinion. Screw on sleeve tool (5049) until .315" (8 mm) of the axle end comes through the retainer. Remove tool.

Power Steering

VOLVO POWER-ASSISTED RACK & PINION (Cont.)

10) Install outer race and spacer sleeve in housing. Press down spacer sleeve so it bottoms on bearing race, then use feeler gauge and straight edge to measure distance between spacer ring and housing. Select gasket(s) of proper thickness, then temporarily install gaskets and cover plate. Gaskets range in thickness from .008-.028" (.2-.7 mm).

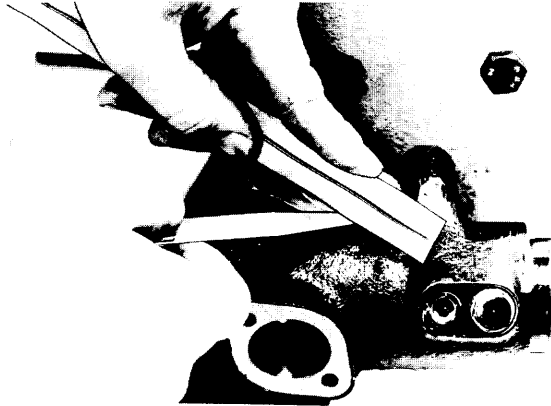

Fig. 11 Measuring for Gasket(s)

NOTE — Cover plate will have to be removed to make servo balance adjustment after steering gear is installed on vehicle. See *GENERAL SERVICING* in this article.

11) Insert "O" ring in valve housing, then install valve housing on gear. Install tool (5171) over splines. Place coil spring in valve housing, large end first. To eliminate the possibility of spring being caught in top groove of valve housing, adjust pinion upwards until spool covers the groove completely.

12) Install valve housing cover, check that coil spring is not squeezed between cover and housing. Pinion shaft shoulder should be .06" (1.5 mm) above cover face. Adjust by using tool (5049) and moving lower bearing inner race. Install lock ring and lock nut.

13) Install damper piston (without "O" ring) in housing. Press piston against rack, then use feeler gauge and straight edge to measure clearance between piston face and housing. Adjust by using shims equal to measured clearance plus .002-.006" (.05-

.15 mm). Shims are available in the following thicknesses: .002" (.051 mm), .0035" (.089 mm), .005" (.127 mm), and .010" (.254 mm).

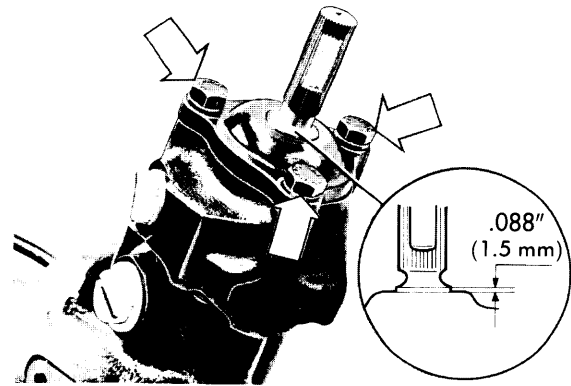

Fig. 12 Pinion Shaft Shoulder Measurement

14) Install "O" ring damper, spring, shims, and cover on housing. Use brass shims as the outer ones in stack. Connect an INCH lbs. torque wrench to pinion shaft and rotate shaft in both directions to stop. Torque should be 8-14 INCH lbs. (9-16 cmkg). If torque is excessive at any point, stop rack in that position and readjust by adding shims.

NOTE — If rack jams with damper removed, rack is warped, and must be replaced.

15) Install oil lines, reinstall left and right steering rods. If installing previously used rods, a thin shim may be placed between ball joint and rack shoulder or the two rods may be swapped in order to obtain an unused portion of the rod for locking.

16) Lock ball joint in rack recess and install bellows, clamps, and tie rod ends, then install steering gear on vehicle. Refill steering gear and power steering unit and check servo balance. See *General Servicing* in this article.

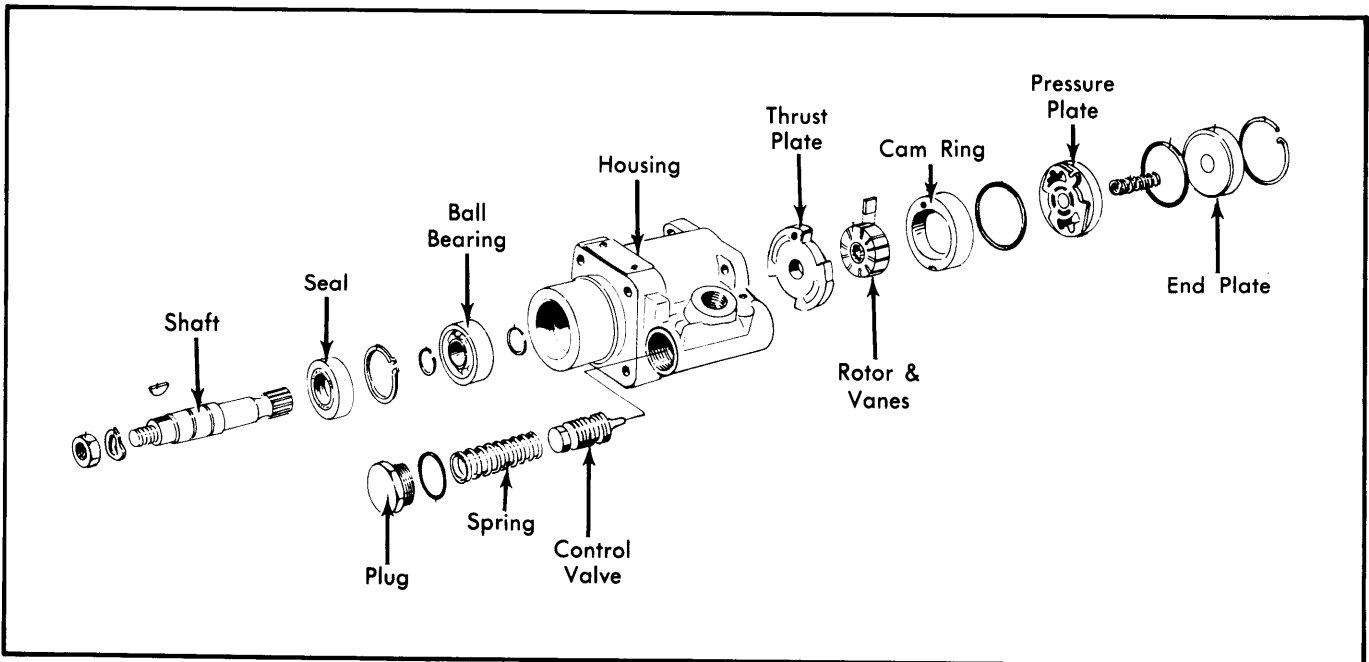

Fig. 13 Exploded View of ZF Power Steering Pump

VOLVO POWER-ASSISTED RACK & PINION (Cont.)

POWER STEERING PUMP

NOTE — Procedures are for the ZF type pump only, manufacturer recommends replacement of the Saginaw type pump if found defective.

Disassembly — 1) With pump removed from vehicle, pry front seal from housing. Remove rear cover snap ring and cover. Take out pressure plate and spring.

2) Turn pump over and tap on end until parts fall free. Remove ball bearing retaining ring, then push shaft out of housing. Push out thrust plate and cam ring, if still in housing.

3) Remove plug, control valve, spring and all "O" rings from housing. Check all parts for wear and scratches. Replace all worn or damaged parts and all "O" rings.

NOTE — If pump housing bushing is defective, replace housing assembly. Rotor, vanes and cam ring are also replaced as an assembly.

Reassembly — 1) Install bearing on shaft (if replaced). Bearing is held by rings on each side. Press bearing and shaft into housing.

2) Snap bearing retaining ring into housing. Install thrust plate in housing making sure dowel is through one of the holes in thrust plate, then place cam ring on dowel, arrow facing up.

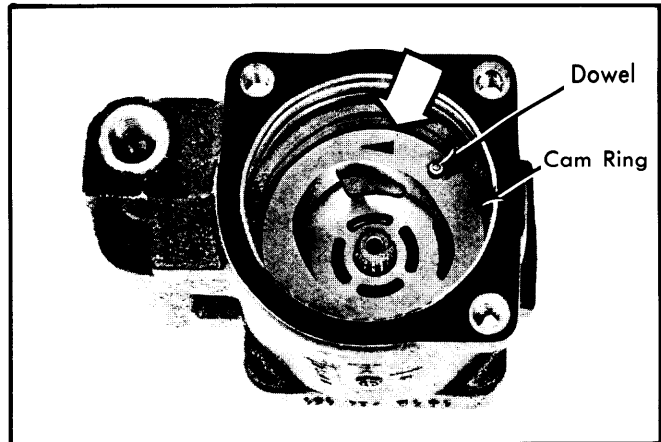

Fig. 14 Cam Ring Installation

3) Install "O" rings in housing, small "O" ring nearest cam ring. Place rotor in housing, then insert vanes in rotor (rounded ends toward cam ring). Install pressure plate with dowel aligned in one of the holes.

4) Insert "O" ring, spring and cover, then press in cover and install retaining ring. Install control valve, spring and plug, then place shaft seal into housing and tap seal lightly until properly seated.

5) Install pump assembly on vehicle, then refill and bleed system. See *GENERAL SERVICING* in this article procedure.