

VOLKSWAGEN TYPE 2 WORM & ROLLER

Type 2

REMOVAL & INSTALLATION

DESCRIPTION

Beginning with 1973 models, Type 2 vehicles incorporated a worm and roller steering unit. This replaced the previously used worm and peg assembly. Steering linkage remains the same as on earlier models, consisting of an adjustable drag link, two maintenance-free tie rods (one adjustable), and a hydraulic steering damper.

ADJUSTMENT

STEERING GEAR

1) Check for excessive free play in steering by raising front of vehicle, placing wheels in straight-ahead position, and lightly turning steering wheel back and forth while holding one of the wheel spokes at outer end. Free play should not exceed $\frac{5}{8}$ " steering wheel spokes at outer end. Free play should not exceed $\frac{3}{8}$ " (15 mm) before resistance is felt in the steering wheel.

2) If free play is excessive, check for loose or worn steering linkage components, check for tight mounting of gear box, and check for proper tightness of gear box cover. If these are found to be in good condition and properly tightened, continue to next step.

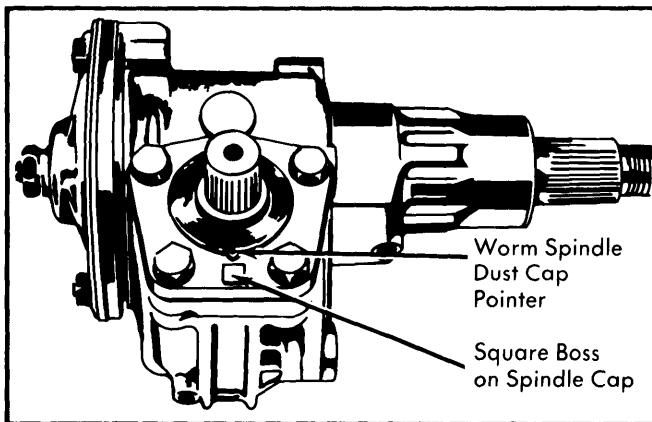

Fig. 1 Steering Gear Aligned in Central Position

3) Disconnect drag link from pitman arm. Turn steering wheel 180-200° from center, in either direction. **NOTE** — Center position is determined when pointer on worm spindle dust cap is in line with square boss on worm cover plate. Loosen adjusting screw lock nut and turn adjusting screw out one full turn.

4) Working under vehicle, move pitman arm back and forth while gradually tightening adjusting screw. Repeat until no play is felt at pitman arm (without stiffness). Hold adjusting screw in this position and tighten lock nut.

5) Take off horn button and disconnect horn wire. Attach a torque gauge to steering wheel nut. Turn steering wheel through centerpoint. Steering is correctly adjusted if torque gauge reads 7-11 INCH lbs. (8-12 cmkg). If necessary, repeat and recheck adjustment.

STEERING GEAR

Removal — From under vehicle, remove cover plate that is below pedal cluster. Detach drag link and remove pitman arm using suitable puller. Bend back lock plate and remove clamp bolt holding coupling flange on worm spindle. Remove gear box mounting bolts and push steering column slightly upward while extracting gearbox from frame.

Installation — To install, reverse removal procedure noting that mark on drop arm is aligned with mark on shaft.

OVERHAUL

NOTE — Manufacturer does not recommend overhaul of the worm and roller steering gear, however a defective roller shaft oil seal may be replaced without removing steering gear box from vehicle.

OIL SEAL REPLACEMENT

To replace seal, remove pitman arm, See Removal, and pry out defective seal. Clean shaft and seal recess, then lubricate new seal. Center seal on shaft and drive into recess with suitable tube. Reinstall pitman arm, and using new lock plate, tighten lock nut to 101 ft. lbs. (14 mkg). Place steering gear in full right lock position and check that steering roller shaft is covered with oil.

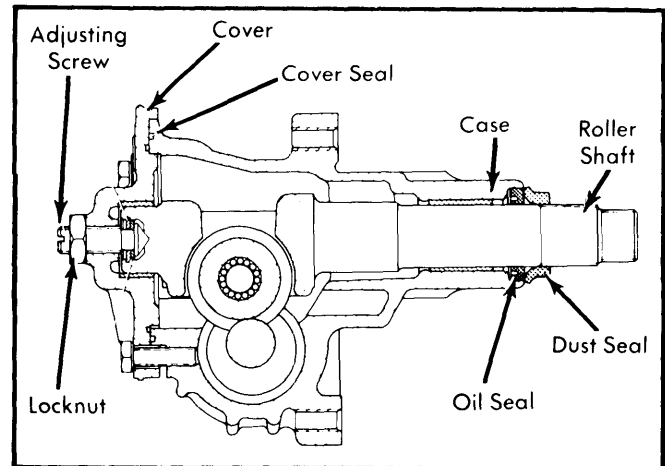

Fig. 2 Cutaway View of Worm & Roller Gearbox

TIGHTENING SPECIFICATIONS

Application	Ft. Lbs. (mkg)
Steering Gear-to-Frame	25-36 (3.5-5.0)
Pinion Shaft Nut	101 (14)
Pitman Arm-to-Drag Link	22 (3)
Adjuster Locknut	36-43 (5-6)
Flange-to-Wormshaft	14 (2)