

Steering Gears & Linkage

SUBARU RACK & PINION

1600

DESCRIPTION

Steering gear, mounted on crossmember, is a rack and pinion type, with backlash automatically adjusted. Pinion is connected to steering shaft by a flexible rubber coupling. Steering knuckle arms are connected to rack by tie rods which are threaded onto ball joint studs at each end of rack.

ADJUSTMENT

Backlash — Backlash is automatically held to a minimum by a spring loaded sleeve which bears against rack. Adjustment is not normally required. End play of sleeve may be corrected if necessary by turning adjusting screw in until it contacts plate, and then backing screw out 1/8 turn to obtain .006" (0.16 mm) end play. Tighten lock nut.

REMOVAL & INSTALLATION

Removal — 1) Raise vehicle and remove front wheels. Remove tie rod ends from steering knuckles. Remove parking brake cable hanger from tie rod. Disconnect pinion from steering shaft rubber coupling. Straighten lock plates and remove bolts retaining gear assembly to crossmember.

NOTE — On 4WD vehicles, also remove fan protector and torque rod.

2) Loosen front engine mounting bolts and raise engine about 0.2" (5 mm) to clear gear assembly. Remove gear assembly from crossmember (toward left side). Remove mounting brackets.

Installation — To install, reverse removal procedure and note the following: Tighten all bolts and nuts to specifications and secure with lock plates or cotter pins as required.

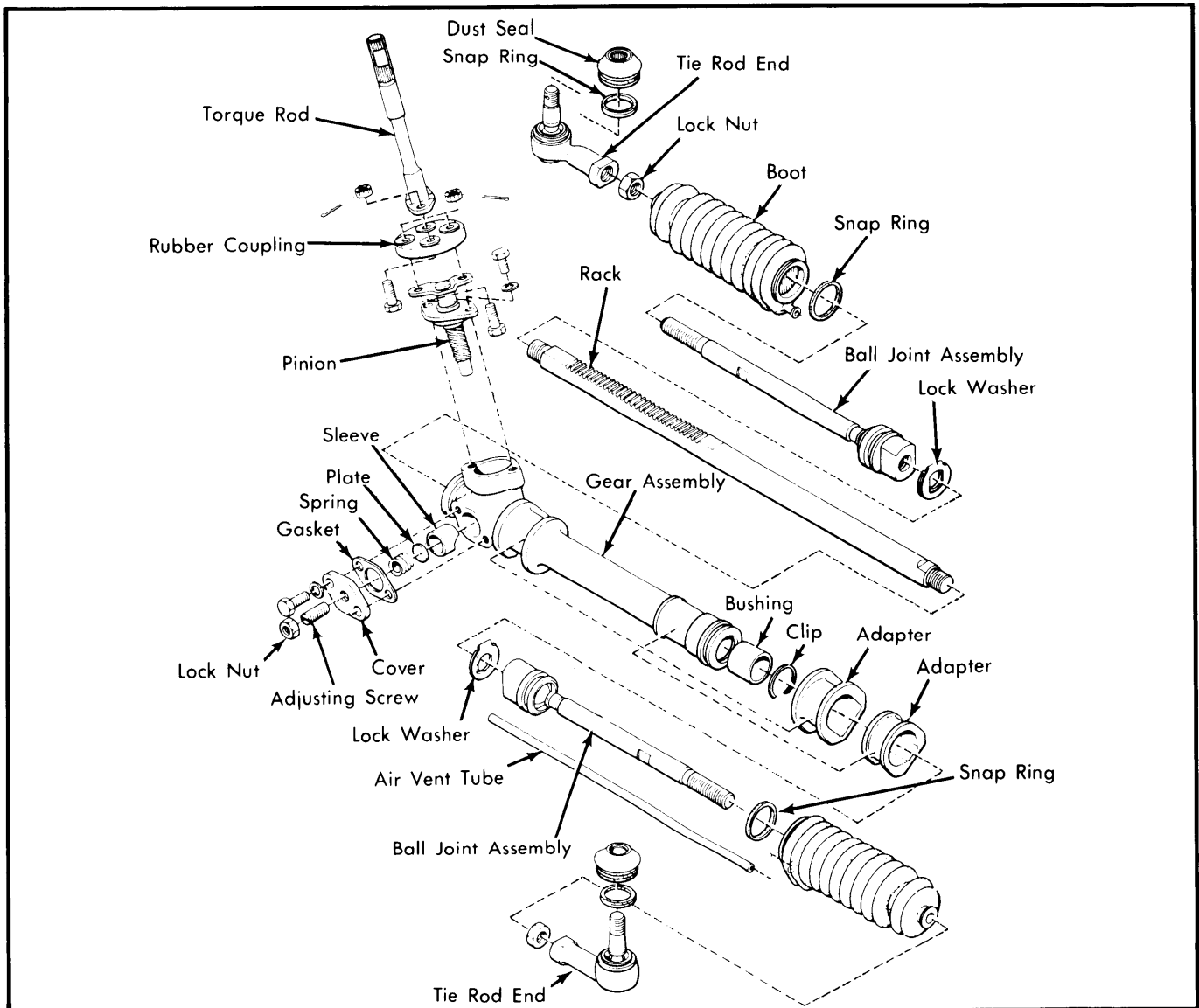

Fig. 1 Exploded View of Subaru Rack & Pinion Steering Gear Assembly

SUBARU RACK & PINION (Cont.)

OVERHAUL

Disassembly – Loosen lock nuts and remove tie rod ends. Remove air vent tube from boots. Remove snap rings from boots and pull boots from gear housing. Straighten lock washers and remove ball joints from rack ends. Loosen lock nut, completely back out adjusting screw, then remove cover, gasket, sleeve spring, sleeve plate, and sleeve. Remove pinion from rack, then remove rack from gear housing.

Inspection – Steering rack should be straight within .010" (0.3 mm). Ball joint play should not exceed .010" (0.3 mm) at 154 lbs. (70 kg). Inspect all parts and replace if worn, damaged, or not within specifications.

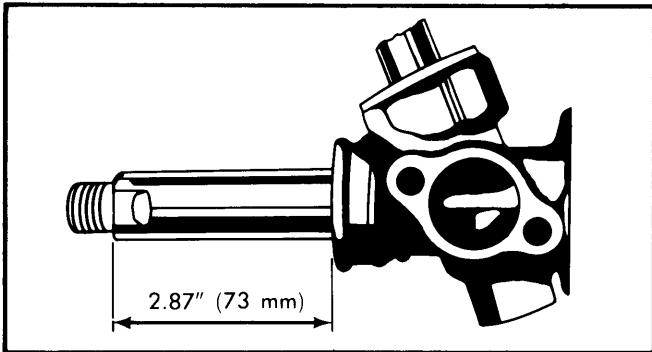

Fig. 2 View Showing Method of Centering Rack in Gear Housing

Reassembly – 1) Grease the toothed and sliding portions of rack and install rack into gear housing. Locate end of rack so that it measures 2.87" (73 mm) from end of gear housing, then grease and install pinion. Tighten pinion assembly to gear housing. In this position, rack and pinion will be centered for vehicle straight-ahead position. When center position has been established, mark the gear housing and pinion with white paint so that marks will align for center position reference.

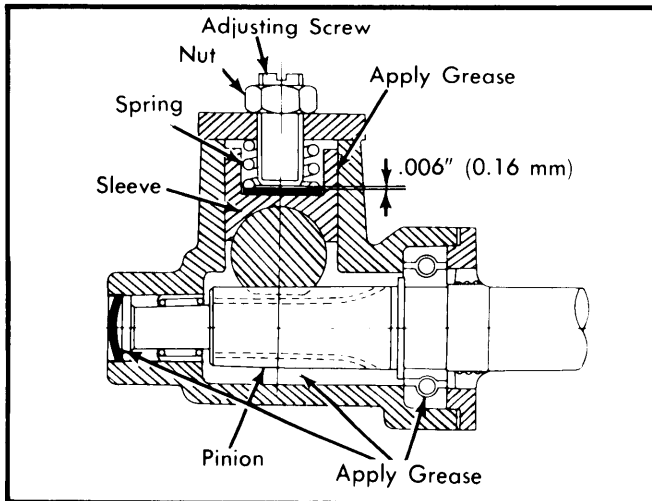

Fig. 3 View Showing Lubrication Points and Backlash Adjustment

2) Install sleeve, plate, spring, gasket, and cover to gear housing and tighten bolts. Turn adjusting screw in until it contacts plate and back off 1/8 turn to obtain .006" (0.16 mm) end play. Tighten lock nut. **NOTE** – Use a suitable locking compound on bolt and adjusting screw threads.

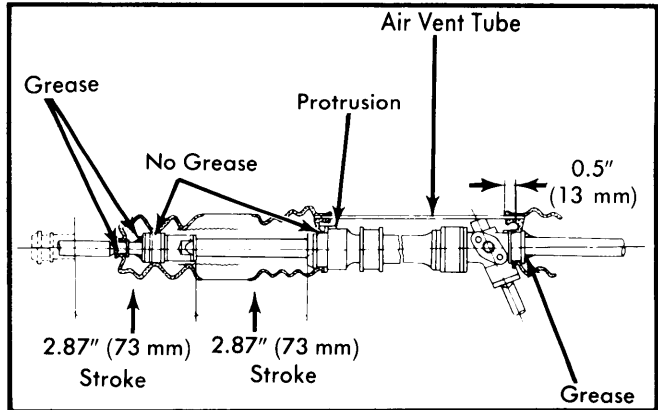

Fig. 4 View Showing Operation Checks and Lubrication of Steering Gear Assembly

3) Install lock washers and ball joints on rack ends. Tighten ball joints and bend lock washers over to secure joints. Install boots on gear housing and retain with snap rings. Install air vent tube into boots while aligning it with embossed mark on gear housing. Install tie rod ends with lock nuts, and temporarily tighten lock nuts. Rotate pinion and check operation of gear assembly. Pinion operating torque in straight ahead position should be less than 1.1 ft. lbs. (0.15 mkg) at ± 1.18 " (± 30 mm) of rack displacement. Maximum torque should not exceed 1.59 ft. lbs. (0.22 mkg).

TIGHTENING SPECIFICATIONS

Application	Ft. Lbs. (mkg)
Pinion Flange-to-Gear Housing	6-9 (0.9-1.2)
Rack Adjuster Cover	6-9 (0.9-1.2)
Rack Adjuster Lock Nut	15-18 (2.1-2.5)
Ball Joint Ass'y-to-Rack	47-54 (6.5-7.5)
Gear-to-Crossmember	33-40 (4.5-5.5)
Rubber Coupling Self-Locking Nut	15-18 (2.1-2.5)
Tie Rod End Castellated Nut	18-22 (2.5-3.0)
Tie Rod End-to-Ball Joint Lock Nut	58-65 (8.0-9.0)