

FIAT 131 RACK & PINION

131

DESCRIPTION

Rack and pinion type steering gear is mounted in rubber insulators and attached to frame. Gear is attached to steering shaft through universal joints. Adjustment is provided for pinion bearing preload. At each end of steering rack, tie rods connect steering mechanism to front wheels.

ADJUSTMENT

NOTE — Adjustments of the pinion bearing preload are performed during overhaul. See Overhaul procedure.

REMOVAL & INSTALLATION

STEERING GEAR

Removal — With wheels in straight ahead position, disconnect tie rod ball joints from steering knuckles. Disconnect steering column universal joint from pinion shaft. Remove bolts securing steering gear assembly to frame and remove steering gear from vehicle.

Installation — Make sure steering wheel is in center position, wheels are straight ahead and pinion gear is centered. Install steering gear assembly to frame. Connect steering column universal joint to pinion shaft and tie rod ball joints to steering knuckles. Check wheel alignment. See *Fiat* in WHEEL ALIGNMENT section.

OVERHAUL

Disassembly — 1) Loosen clamps securing dust boots to tie rod and gear housing. Slide boots onto the tie rod and position gear assembly into vise so that rack is securely clamped. Remove one tie rod inner ball joint from rack.

NOTE — Ball joints are staked to rack, do not remove other ball joint unless replacement is necessary.

2) Remove rack piston plug, spring and rack piston from gear housing. Slide rack out of gear housing. Remove pinion shaft nut, plastic bearing half and pinion shaft.

Assembly & Adjustment — 1) Inspect plastic bearing half in gear housing, remove and replace if necessary. Inspect roller bearing on pinion shaft and lower bearing in gear housing. Remove and replace as necessary.

2) With lower bearing in gear housing and lower plastic bearing installed, slide rack into gear housing. Install pinion shaft and upper half of plastic bearing. Install pinion shaft nut and tighten to specification. Check torque required to turn pinion shaft (with rack installed). Torque should not exceed 4 ft. lbs. (.5 mkg). With pinion torque correct, stake pinion nut in four places.

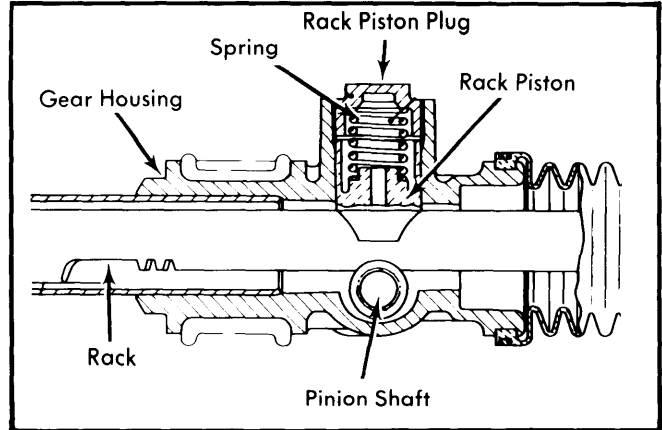

Fig. 1 Sectional View of Rack Piston Assembly

3) Center rack in gear assembly. Install rack piston, spring and rack piston plug. Stake plug in four places. With dust boots on tie rods, lubricate tie rod inner ball joint with oil and install on rack. Tighten ball joint collar to specification, then stake to rack.

4) Slide one dust boot onto gear housing and secure to gear housing and tie rod with clamps. Stand steering gear assembly on end and pour 5-5.2 oz. (145-155 cc) of oil (SAE 90 EP) into gear housing. Install other dust boot.

NOTE — Lubricate dust boots with a silicone spray and be sure they are not twisted after installation.

TIGHTENING SPECIFICATIONS

Application	Ft. Lbs. (mkg)
Pinion Shaft Nut	22-23 (3-3.2)
Tie Rod Inner Ball Joint	11 (1.5)

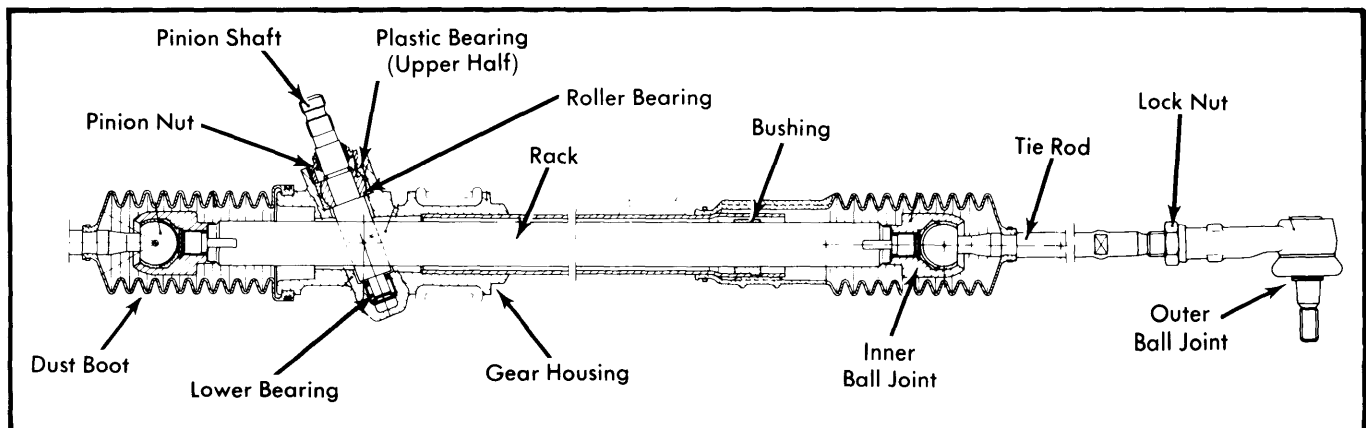

Fig. 2 Sectional View of Rack & Pinion Steering Gear Assembly