

DATSUN 280Z RACK & PINION

280Z

DESCRIPTION

Steering assembly is a direct-acting rack and pinion system, with a gear ratio of 18.0:1. This unit consists of a rack bar and toothed pinion, both working in the plain bearing of the housing. Backlash is held to zero by the retainer and the retainer spring.

REMOVAL & INSTALLATION

Removal — Raise and support front of vehicle; remove front wheels. Disconnect column joint from rubber coupling (two bolts). Unbolt lower joint from gear pinion and remove lower shaft assembly. Remove splash shield, then pull tie rods from steering knuckle arms. Unbolt gear housing from front member and remove rack and pinion assembly.

Installation — Install in reverse order of removal procedure. Check wheel alignment. For wheel alignment procedures, see *Datsun in WHEEL ALIGNMENT* section.

ADJUSTMENT

NOTE — Adjustments are performed during gear assembly process. See *Overhaul* as outlined.

OVERHAUL

Disassembly — 1) Clamp gear housing horizontally in a padded vise. Unclamp dust boot and pull boot outward to expose inner end of tie rod. Loosen tie rod retaining nut, detach tie rod socket, and remove tie rod from rack. Withdraw spring seat and tie rod spring.

2) Loosen rack adjuster lock nut (on housing), then remove adjuster, spring, and rack damper. Pry oil seal from pinion shaft, then remove pinion cover bolts, cover, and adjusting shims. Draw out pinion assembly, then rack, from housing. Pry pinion lower bearing from housing, then press pinion upper bearing from pinion gear.

Assembly & Adjustment — 1) Press bearing onto pinion gear. With gear horizontal in padded vise, thinly coat rack teeth and sliding surfaces with suitable multi-purpose grease. Install pinion lower bearing into housing, with seal side upward, then insert pinion.

2) Set initial pinion turning torque, by selecting an adjusting shim which will give 2.6-5.2 INCH lbs. (3-6 cmkg) when pinion cover is installed and bolts are tightened (rack is not installed). Shims are available in the following sizes: .002" (.05 mm), .005" (.127 mm), .01" (.25 mm), .02" (.5 mm), and .04" (1 mm).

3) Remove pinion cover and pinion gear. Insert rack into housing, making sure rack protrudes same amount from each end. Coat pinion gear and bearing with suitable multi-purpose grease. Install pinion and properly mesh pinion gear with rack teeth. Recheck rack for equal protrusion at ends of housing. Reinstall and tighten pinion cover (with shim). Install pinion oil seal.

4) Check pinion for smooth rotation and minimal axial play. Measure axial play with a dial gauge. Play must not exceed .012" (.3 mm). If it does, recheck condition of gear and rack teeth, bearings, and adjustment shim.

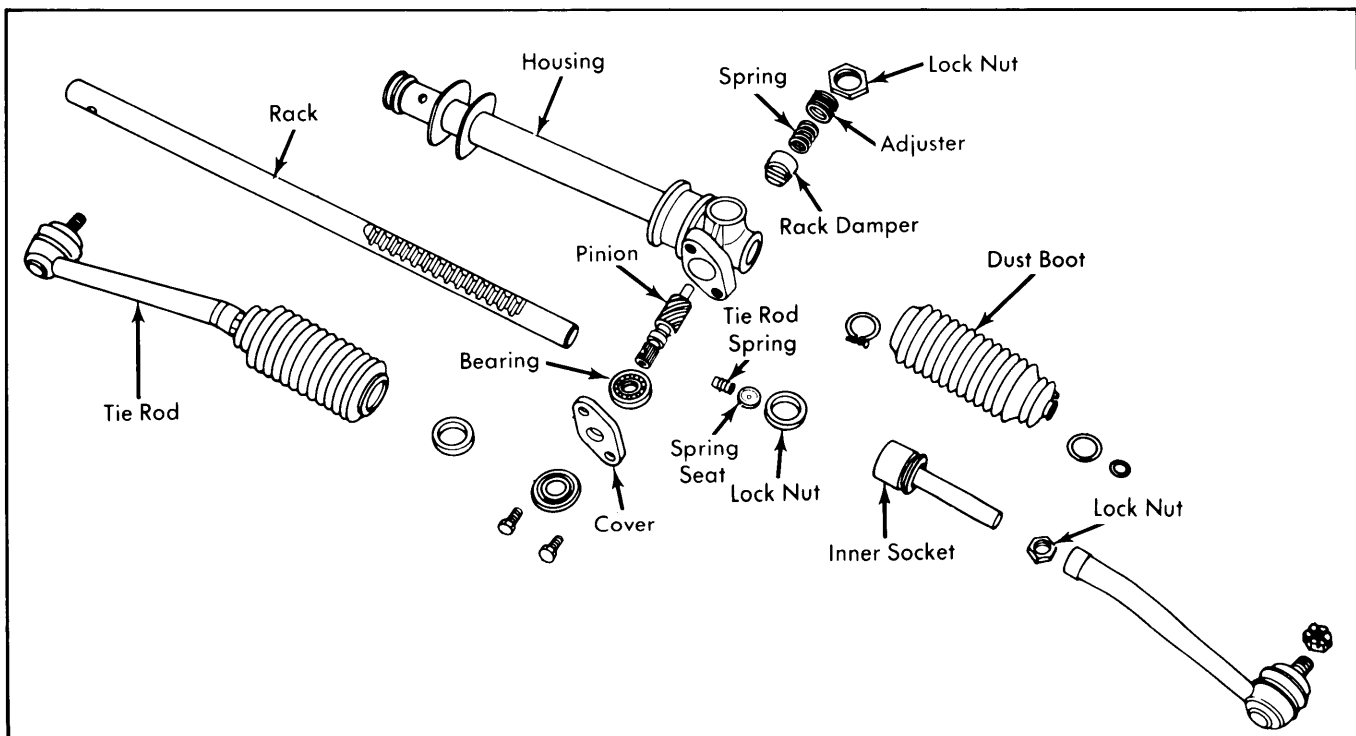

Fig. 1 Exploded View of Rack & Pinion Steering Gear Assembly

Steering Gears & Linkage

DATSUN 280Z RACK & PINION (Cont.)

5) Grease rack damper, then insert damper and spring into housing. Screw in adjuster and install lock nut. Turn in adjuster until damper is tight. Check pinion rotary torque. If beyond 0-17 INCH lbs. (0-20 cmkg), select a suitable adjuster shim for placement on top of rack damper, which will bring rotary torque within limits. Shims are available in the following sizes: .01" (.25 mm), and .04" (1 mm). Apply sealer around lock nut.

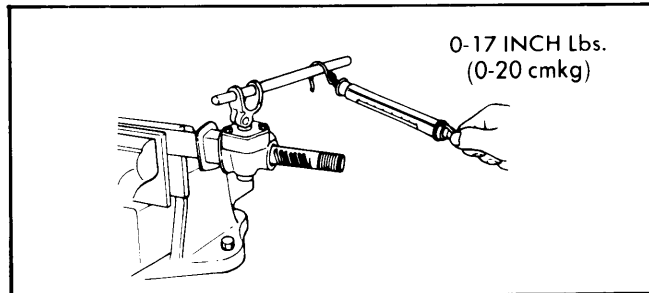

Fig. 2 Measuring Pinion Shaft Rotary Torque

6) After gear assembly is complete, recheck pinion rotary torque and force required to move rack. Pinion rotary torque should remain same as previously described, and rack pull force should be 31-37 lbs. (14-17 kg). If these torques are not within limits, readjust rack damper adjuster.

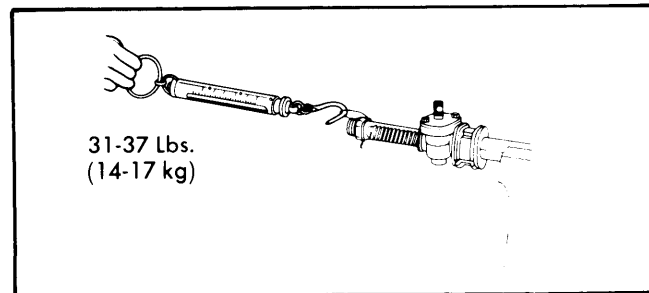

Fig. 3 Measuring Steering Gear Rack Pulling Force

7) Position dust boots on tie rod. Thread lock nut spacer and lock nut over threaded portion of rack. Coat sliding surfaces of tie rod inner socket and spring seat. Fit tie rod assembly to rack end with inner spring and spring seat. **NOTE** — Ensure proper tie rod is installed on correct side. Left tie rod is marked with an "L", right tie rod has no marking.

8) Screw inner socket portion until ball seat reaches rack end, then tighten lock nut securely. Upon completion of tie rod assembly, measure swinging torque and axial play of inner ball joint. Swinging torque (measured at outer end of tie rod) should be 0-43 INCH lbs. (0-50 cmkg). Axial play of inner ball joint should not exceed .002" (.05 mm).

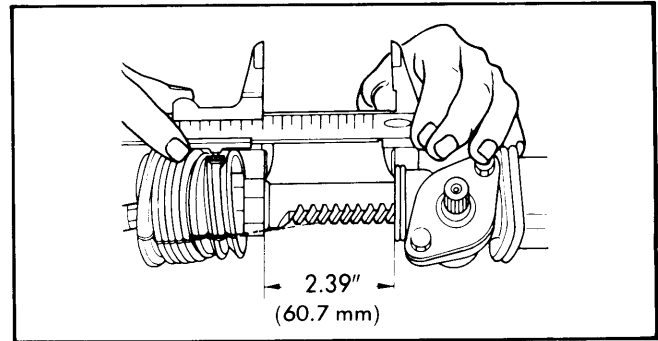

Fig. 4 Measuring Steering Gear Rack Protrusion

9) Measure rack protrusion. It should be 2.39" (60.7 mm). Attach boot and clamps, insert grease nipples at both ends of housing, and lubricate gear assembly (until a small amount of grease appears at boot outlet hole). Adjust tie rod length so that distance from outer side of lock nut to end of boot mounting groove is 1.492" (37.9 mm).

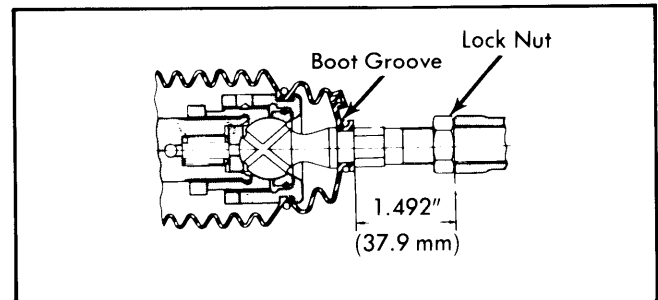

Fig. 5 Adjusting Steering Gear Tie Rod Length

TIGHTENING SPECIFICATIONS

Application	Ft. Lbs. (mkg)
Pinion Cover Bolts	14-22 (1.94-3.04)
Adjuster Lock Nut	29-36 (4.01-4.98)
Inner Socket Lock Nut	58-72 (8.02-9.95)
Tie Rod Lock Nut	58-72 (8.02-9.95)
Column-to-Gear Clamp Bolt	6-8 (0.83-1.11)
Rubber Coupling Bolt	12-14 (1.66-1.94)
Lower Joint-to-Rubber Coupling Bolt ..	17-20 (2.35-2.77)
Lower Joint-to-Pinion Clamp Bolt	29-36 (4.01-4.98)