

AUDI

100LS
Fox

REMOVAL & INSTALLATION

Removal, 100 – 1) Remove lower instrument panel trim from around steering column. Pry off steering wheel pad. Unscrew steering wheel mounting nut and remove steering wheel. Unscrew and remove horn slip ring, column casing, and horn ground contact. Pull three washers from top of steering column. Detach electrical leads from column switches; remove switches.

2) Loosen support bolt from bracket below instrument panel. Note position of plastic slide pieces. In engine compartment, detach lower end of steering column from pinion shaft by removing pinch bolt.

3) Dislodge rubber grommet from around column in firewall. Lift column assembly out of vehicle. **CAUTION** – This is a telescopic safety steering column and must be handled with care to prevent accidental collapsing of column.

Installation – When installing column, ensure plastic slide pieces are in place when mounting column to instrument panel. Be sure grommet is in place on end of support tube. Replace rubber grommet in firewall after filling groove in rubber cover with transmission lubricant.

Removal, Fox – 1) Pull off steering wheel horn control by hand. Disconnect ground wire at horn button. Remove steering wheel mounting nut and pull off steering wheel. Unscrew switch base cap and disconnect plugs at both lever switches and horn contact ring.

2) Remove upper and lower instrument panel trim from around column. Unscrew bearing flange at bottom of steering column. Remove steering shaft-to-pinion pinch bolt (in engine compartment), pry off clip and drive steering column off pinion (use a brass mandrel).

3) Remove upper instrument panel trim to make shear screws accessible. **NOTE** – These screws are also upper steering column support screws. Drill off heads of shear screws. Remove steering lock and allow to hang by wiring. Remove steering column (Fig. 1).

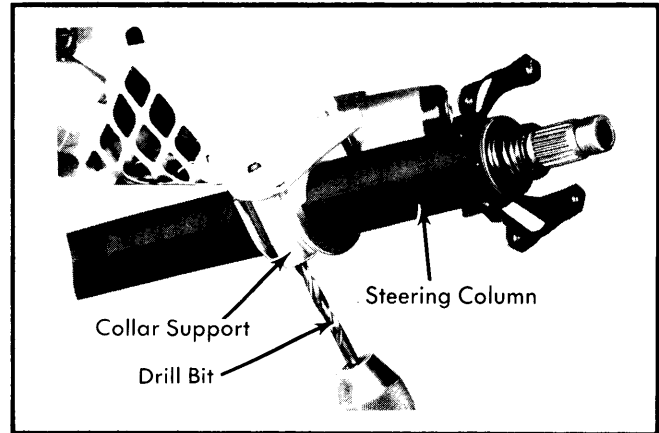

Fig. 1 Drilling Out Shear Bolts and Dropping Column Mounting Collar – Fox Models Shown

Installation – To install, reverse removal procedures, noting the following; Column has two bores for securing and locating steering lock; casting on clamp portion of lock must engage with LOWER bore in column tube. Always use self-locking nuts when installing pinch bolt at pinion. When replacing column bearing flange, longer portion of flange must be toward passenger's side.

OVERHAUL

Remove stop washer from top end of column, then remove plain washers, spring, and support. Slide column down into tube in order to gain access to column bearing. **NOTE** – After column is reassembled and installed, check for proper operation of lock mechanism BEFORE shearing heads of lock mounting screws.

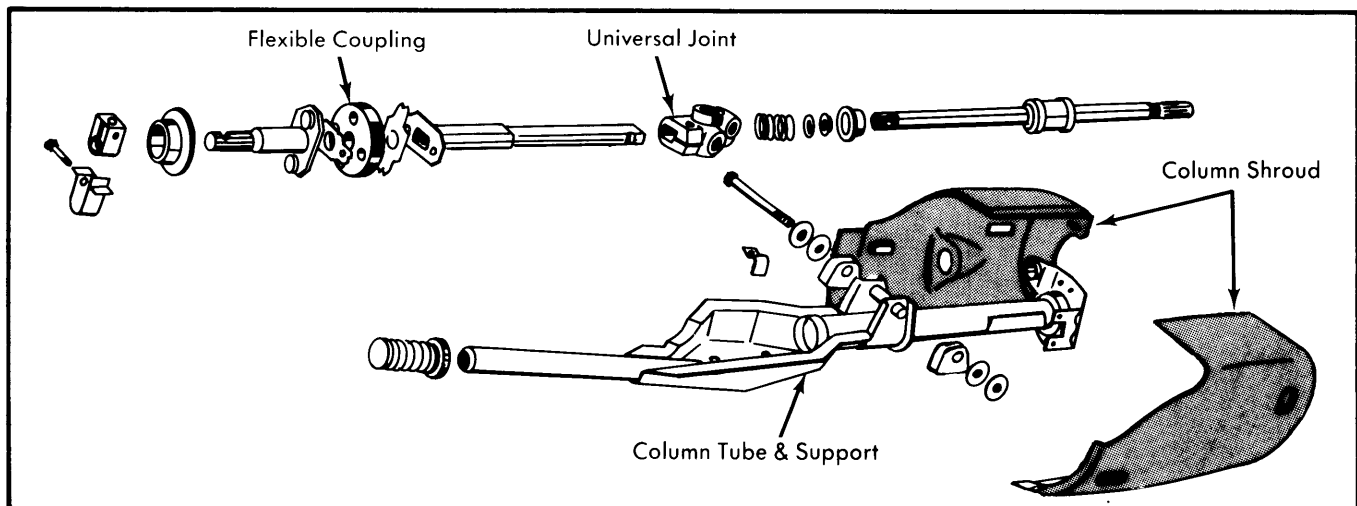

Fig. 2 Audi 100LS Steering Column Assembly