

Steering Wheel & Column Switches 10-5

CAPRI (Cont.)

TURN SIGNAL & IGNITION SWITCHES

Removal – Disconnect battery. Remove steering column shroud upper and lower halves. Remove turn signal switch retaining screws, disconnect electrical plug and remove turn signal switch. Place ignition key in the "O" position, then remove screws from the lower left trim panel. Disconnect electrical plug from emergency flasher then remove trim panel. Disconnect ignition wires at connector then remove screws securing ignition switch to lock and remove ignition switch.

Installation – To install, reverse removal procedure, making sure that ignition key is in the "O" position and all wires are reconnected.

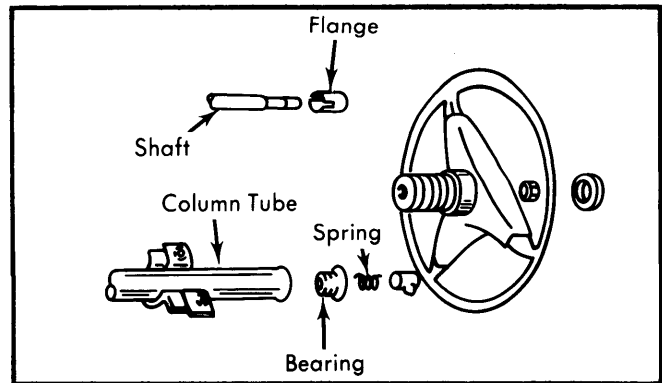

Fig. 1 Capri Steering Wheel Components

COURIER

Courier

REMOVAL & INSTALLATION

STEERING WHEEL & COMBINATION SWITCH

Removal – 1) Disconnect battery ground cable. Remove steering wheel nut cover. Index mark main shaft and steering wheel. Disconnect electrical leads. Pull steering wheel from shaft.

2) Remove plastic hazard light indicator and steering column shroud. Disconnect electrical wires at base of steering column. Remove headlight switch knob from shaft.

3) Remove snap ring retaining switch and force turn indicator cancelling cam off shaft. Take out single bolt, near bottom of switch, and pull out complete switch assembly.

Installation – 1) Fit switch assembly on steering column then, refit one retaining bolt. Place turn indicator cancelling cam into position and install snap ring. Reconnect electrical plug at column base.

2) Insert and tighten headlight knob switch. Install column shroud and plastic hazard light indicator. Refit steering wheel with index marks aligned. Connect battery ground cable.

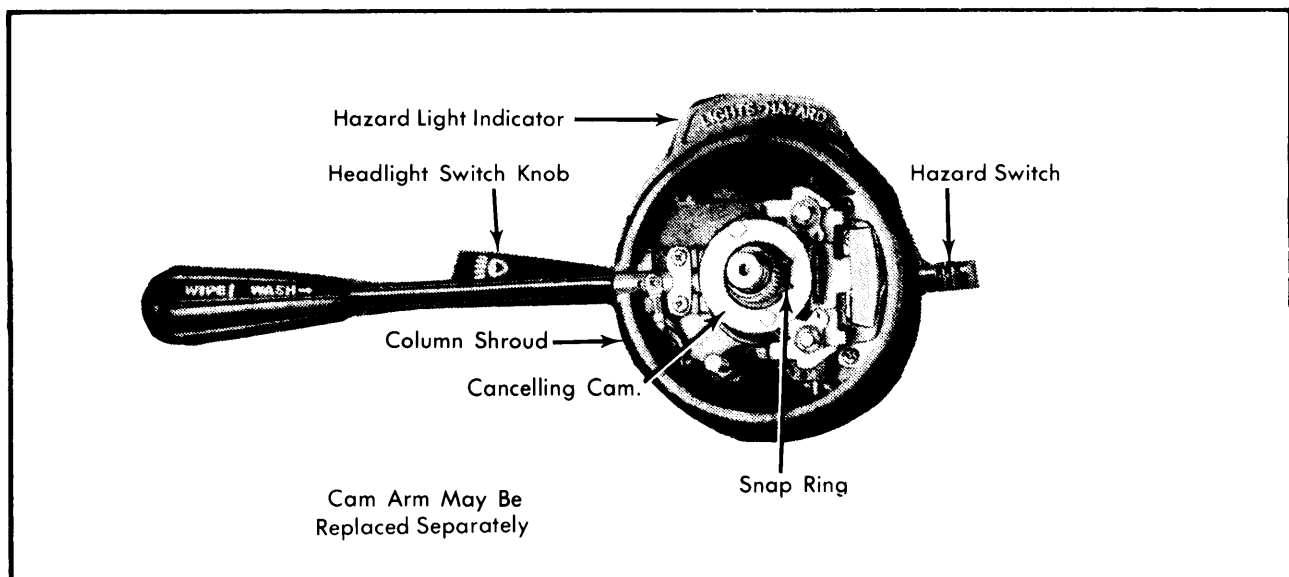

Fig. 1 Top View of Steering Column with Steering Wheel Removed to Expose Combination Switch