

JAGUAR

XJ6
XJ12
XJS

DESCRIPTION

Independent, coil spring type suspension. Outer bearing carrier and hub assembly is supported by control arms at bottom and utilizes drive axles as upper support. Suspension is controlled by two coil spring/shock absorber assemblies mounted at each rear wheel. Movement of lower control arms are controlled by radius arms connected to control arms at rear and to chassis members at front.

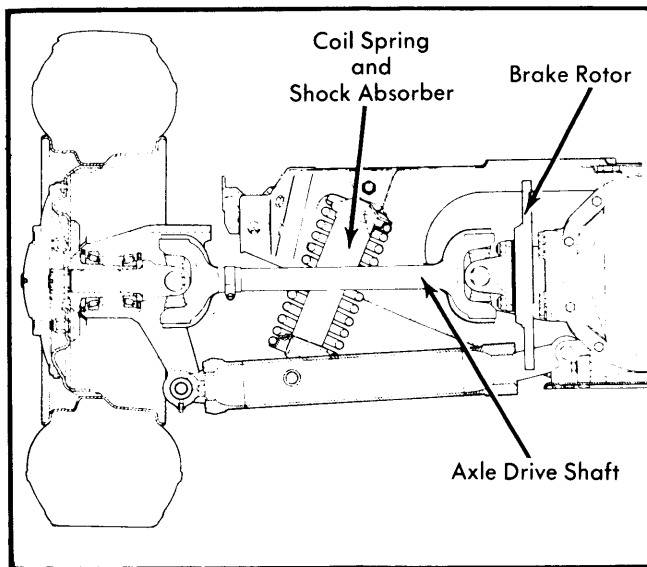

Fig. 1 Jaguar Rear Suspension Assembly

ADJUSTMENTS

WHEEL ALIGNMENT SPECIFICATIONS & PROCEDURES

See *Wheel Alignment Specifications and Procedures* in *WHEEL ALIGNMENT* Section.

REMOVAL & INSTALLATION

COIL SPRING & SHOCK ABSORBER

NOTE — Rear springs can be removed with rear suspension installed in vehicle.

Removal — Raise vehicle and support at lift points with jack stands. Position floor jack under control arm. Remove nut and bolt mounting top of shock absorbers to the suspension assembly crossmember. Remove washers and nuts securing shock absorbers to lower mounting. Using a drift, remove mounting piece. Withdraw shock absorber and coil spring assembly. Using a spring compressor, collapse spring until collets and spring seat can be removed. Release pressure and separate shock absorber from spring.

Installation — To install spring and shock absorber assembly, reverse removal procedure and tighten all nuts and bolts.

RADIUS ROD

Removal — 1) Raise and support vehicle on safety stands forward of radius rods. Remove tire and wheel. Remove bolt and spring washer securing safety strap to body. Remove lock wire and bolt securing radius rod to body, then remove safety strap.

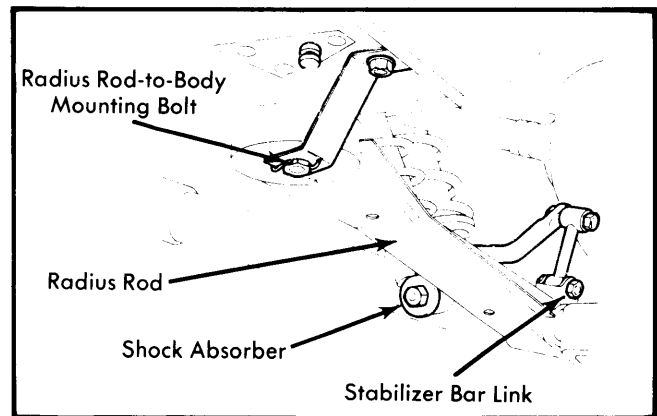

Fig. 2 Installed Position of Radius Rod

2) Remove forward lower shock absorber mounting pin. Using a punch, remove pin rearward. Bend tab washer and remove bolt mounting radius rod to control arm.

Installation — Replace any damaged radius rod bushings. When pressing bushings into radius rod, bushing should protrude from each side equal amounts. To install, reverse removal procedure.

REAR SUSPENSION ASSEMBLY

Removal — 1) Raise vehicle and place on safety stands forward of radius rods. Remove tire and wheel. Remove clamps mounting exhaust system. Disconnect exhaust system pin from rubber mounting and guide intermediate pipes from rear suspension. Disconnect radius rod mounting hardware.

2) Separate brake line from body mounting bracket and plug openings. Disconnect propeller shaft and parking brake cable linkage. Position jack under rear suspension unit, remove the nuts securing mounting bracket to body. Lower jack and remove suspension unit.

Installation — To install, reverse removal procedure and ensure radius rod is wired to safety strap.

LOWER CONTROL ARM OUTER FULCRUM SHAFT

Removal — Remove rear suspension assembly as previously outlined. Support hub and control arm. Remove lock nut securing fulcrum shaft (note positioning of shims). Separate hub from control arm (see illustration). To install, reverse removal procedure and tighten nuts and bolts to specifications.

Disassembly — Remove oil seal track and pry out oil seal. Remove inner races by tapping with a punch in the grooves provided. Remove spacers and shims noting number and position.

JAGUAR (Cont.)

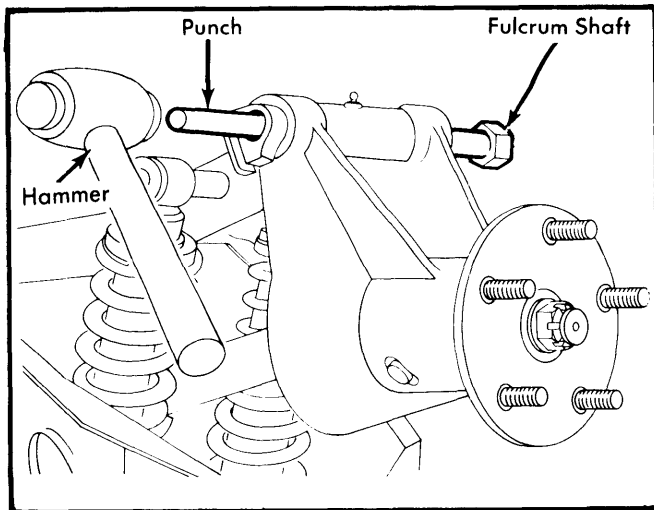

Fig. 3 Outer Fulcrum Shaft Removal

Reassembly – Install bearing inner race, shims and spacers. Install roller bearings, oil seal, and oil seal track.

Installation – Using suitable pilot shaft (J 14), slide shaft through lower control arm and hub, install shims in reverse of removal. Install fulcrum shaft, tighten nuts and bolts to specifications.

LOWER CONTROL ARM

Removal – Remove rear suspension assembly as previously outlined. Remove lock nuts and bolts securing tie plate to crossmember and inner control arm fulcrum bracket. Remove tie plate. Remove lower control arm outer fulcrum shaft, radius arm from control arm and coil spring/shock absorber assembly as previously outlined. Remove lock nut securing control arm fulcrum shaft to crossmember and remove fulcrum shaft. Remove lower control arm, note location of thrust washers, oil seals and retainers. If fulcrum mounting bracket is to be removed, remove lock wire and set screws securing bracket to differential. Remove bracket.

Disassembly – Remove bearing tubes and needle bearings by tapping gently with a suitable punch.

Reassembly – Install bearings and tubes with engraving on bearings facing outwards.

Installation – Use suitable pilot shaft (J 14) to align control arm with crossmember. To install, reverse removal procedure and tighten nuts and bolts to specifications.

STABILIZER BAR & LINKS

Removal, XJS – Raise vehicle and place on safety stands. Remove left rear wheel. Loosen exhaust pipe clamp nuts on right side forward of crossmember. Remove bolts mounting stabilizer bar to top of connecting links. Remove brackets mounting stabilizer bar to floorpan. Pull exhaust pipe apart. Maneuver stabilizer through left fender opening. Remove nuts and bolts mounting connecting link, then separate from radius rod.

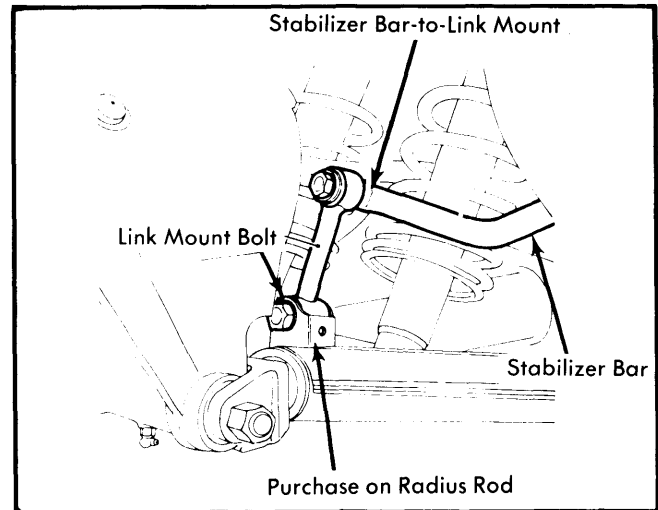

Fig. 4 Installed View of Stabilizer Bar and Connecting Link

Installation – To install stabilizer bar and connecting links, reverse removal procedure. Make sure exhaust system does not leak.

TIGHTENING SPECIFICATIONS

Application	Ft. Lbs. (mkg)
Radius Rod-to-Control Arm	60-70 (8.3-9.7)
Radius Rod & Safety Strap-to-Body	40-45 (5.5-6.2)
Safety Strap-to-Body	27-32 (3.7-4.4)
Suspension Mounts	15-18 (2.1-2.5)
Shock Absorbers	30-36 (4.2-5.0)