

BMW

2002
3.0
530i

DESCRIPTION

Independent type rear suspension with coil springs. Semi-trailing control arms pivot on crossmember and connect to axle shaft bearing housings. Coil springs and shock absorbers are mounted on control arm perches and operate between arm and upper body. A stabilizer bar is attached to crossmember and linked to both control arms.

REMOVAL & INSTALLATION

SHOCK ABSORBERS & COIL SPRINGS

Removal, 4 Cylinder Models — Raise and suitably support vehicle, then remove tire. Support control arm with a jack. Remove shock absorber top mounting. Unscrew bottom shock absorber mount. Compress shock absorber (pulling down) and remove from vehicle. Unbolt stabilizer bar from trailing arm. Separate axle drive shaft from drive shaft, then pull shaft back out of way. Lower trailing arm with jack and pull out coil spring.

Installation — To install coil spring and shock absorber, reverse removal procedure and note the following: Replace coil spring damper rings if necessary. Lower damper ring recess goes in protrusion on control arm plate. Tighten shock absorber with vehicle weight under normal load.

Removal, 6 Cylinder Models — Raise vehicle and support with safety stands, remove tire. Place a jack under control arm. Disconnect shock absorber at lower mount on control arm. From top end of shock absorber, remove centering shell and mounting nuts. Remove shock absorber complete with spring assembly.

Disassembly & Reassembly — Using a spring compressor, collapse spring and remove centering shell. Remove coil spring and boot. Pull retainer and auxiliary spring off shock absorber. Inspect spring and boot for wear and replace any parts found defective. To reassemble, reverse disassembly procedure and ensure coil spring is properly aligned before releasing spring compressor. Vent opening on auxiliary spring faces inside retainer.

Installation — To install shock absorber, reverse removal procedure and tighten all nuts and bolts.

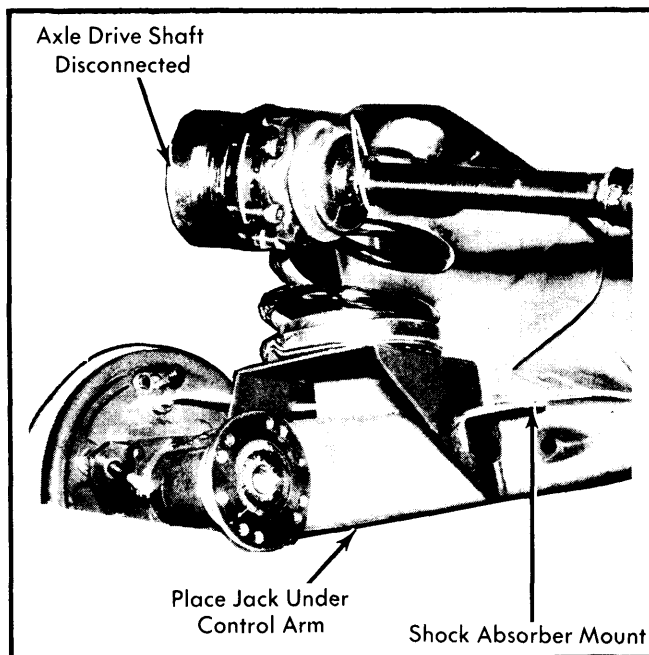

Fig. 1 View Showing Preparation for Coil Spring Removal

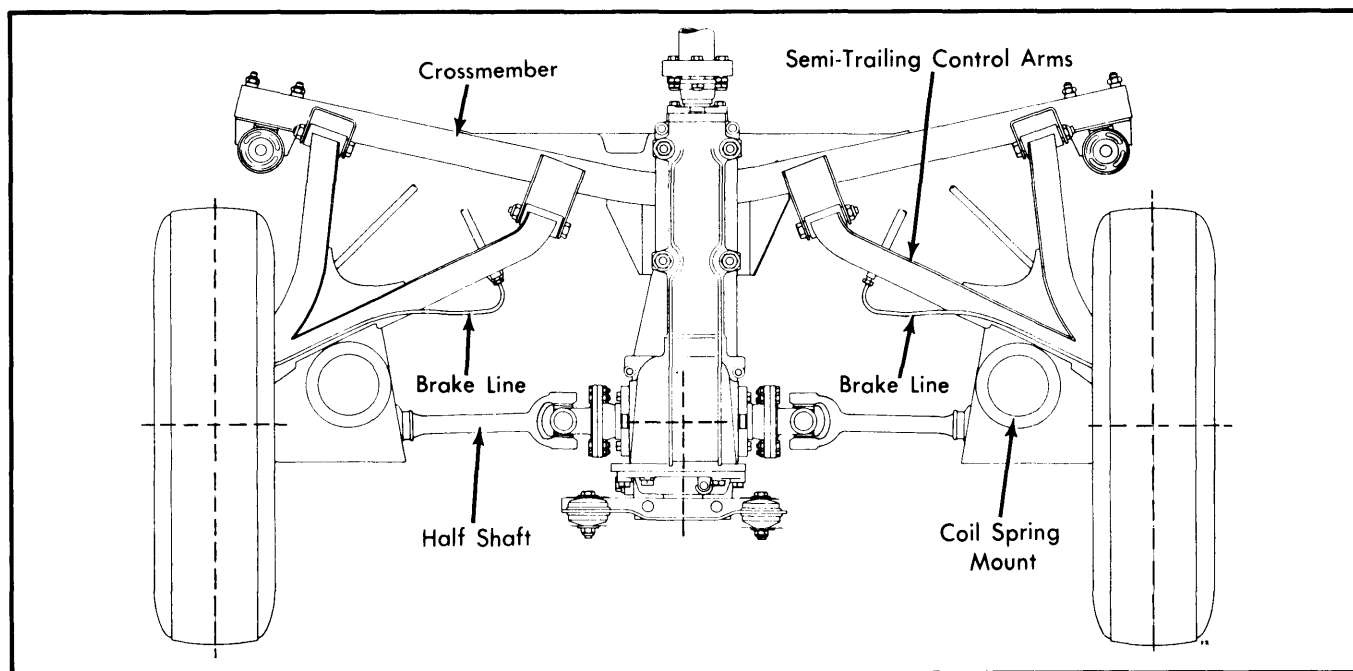

Fig. 2 BMW Rear Suspension Assembly

Rear Suspension

BMW (Cont.)

SEMI-TRAILING CONTROL ARM

Removal — Raise and support vehicle; remove tire. Support control arm under spring seat and also support final drive unit. Remove nuts and bolts securing stabilizer bar to control arm. Remove shock absorber and coil spring assembly. Disconnect axle drive shaft. Disconnect parking brake cable at lever.

Disassembly & Reassembly — With control arm fixed in suitable support plate, see illustration, press or drive out bushings and install new ones.

Installation — To install, reverse removal procedure and tighten all nuts and bolt. Bleed and adjust brakes.

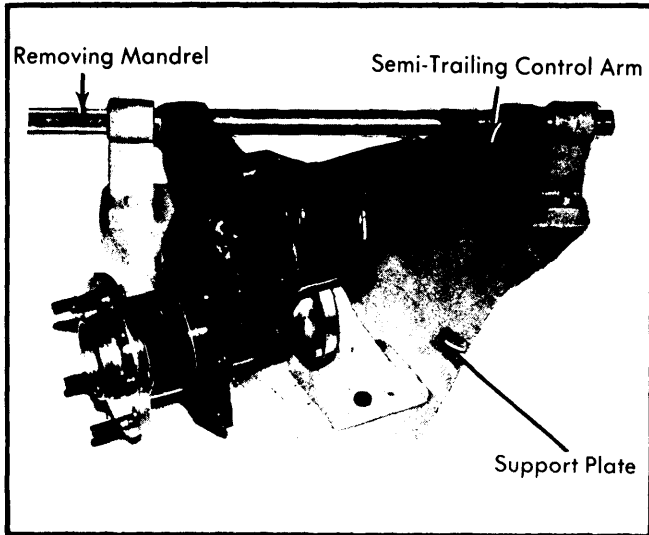

Fig. 3 View Showing Control Arm Bushing Replacement Procedure

TIGHTENING SPECIFICATIONS

Application (4 Cylinder)	Ft. Lbs. (mkg)
Large Final Drive Cover	31 (4.3)
Flange on Bevel Pinion	108 (14.9)
3-Arm Flange	108 (14.9)
Side Cover	15 (2.1)
Hex. Bolt in Drive Flange.....	75 (10.4)
Drive Pinion Bearing Stop	289 (40.0)
Axle Shaft Castellated Nut	244 (33.7)
Crownwheel-to-Final Drive	57 (7.9)

Application (6 Cylinder)	Ft. Lbs. (mkg)
Housing Cover	16 (2.2)
Crownwheel-to-Differential	86 (11.9)
Input Pinion Shaft	108 (15)
Rear Stub Axle-to-Drive Flange.....	180 (25)
Axle Shaft-to-Drive Flange.....	46 (6.4)
Crossmember-to-Body	107 (14.8)
Thrust Links-to-Body.....	19 (2.6)
Hex. Bolt in Drive Flange.....	68 (9.4)
Upper Shock Absorber Mounting.....	19 (2.6)
Lower Shock Absorber Mounting	94 (13.0)