

AUDI 100LS

100LS

DESCRIPTION

Suspension is a torsion bar type utilizing a solid axle. Torsion bars are mounted inside a tube connected to chassis. Torsion bars are mounted solid inside tube and are connected at outside to spring plates. Spring plates are connected at rear to solid axle. A stabilizer bar is also employed.

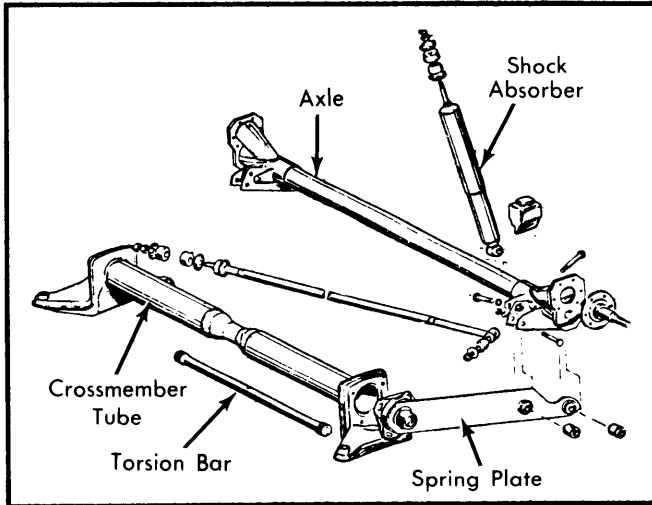

Fig. 1 Exploded View of Rear Suspension Assembly

ADJUSTMENT

WHEEL BEARING ADJUSTMENT

See *Wheel Bearing Adjustment* in *WHEEL ALIGNMENT* Section.

REMOVAL & INSTALLATION

REAR SUSPENSION ASSEMBLY

NOTE — Complete rear suspension assembly, including solid axle can be removed as a unit.

Removal — 1) Push brake pedal down and secure at a position approximately 3" (76 mm) from full up position. This closes compensating port in brake master cylinder. Raise vehicle and position safety stands under chassis. Remove rear wheels. Disconnect both shock absorbers from rear axle.

2) Loosen nut at parking brake cable adjustment point until cable can be slid from bracket. Pull back plastic sleeve at cable mount on chassis and push back rubber boot. Pull cable to rear and slide through slot in holding bracket. This procedure applies to cable brackets on both sides.

3) Disconnect brake line from flex line. Plug both lines on both sides. Position a jack under suspension crossmember tube and remove bolts securing tube to chassis. Lower jack and remove complete rear suspension assembly.

NOTE — When installing rear suspension assembly, a suitable centering tool (*Centering Tool Gauge No. H-100*) is required.

Installation — 1) Position suspension assembly in vehicle in approximate position and install front bolts and washers securing crossmember tube to chassis but do not tighten. Install centering tool on crossmember tube. Insert centering bolt in hole in crossmember tube.

2) **CAUTION** — Bolt should not be inserted with force, move tool until bolt can be inserted easily. With tool firmly attached to tube, move tube laterally until measuring bolts can be inserted easily into tool body. Install and tighten remaining crossmember tube bolts and remove centering gauge. Reverse removal procedure to complete installation.

CROSSMEMBER TUBE & TORSION BARS

Removal — 1) Push brake pedal down and secure at a position approximately 3" (76 mm) from full up position. This closes compensating port in brake master cylinder. Raise vehicle and position safety stands under chassis. Remove both rear wheels.

2) Disconnect brake line at flex line and plug both openings. Remove stabilizer bar from crossmember tube and from axle. Remove bolts securing torsion bar spring plates to rear axle mounts. Remove bolts, bend open retaining clamps and remove parking brake cable from spring plates. Remove crossmember tube mounting bolts and remove crossmember tube assembly.

Disassembly — Position crossmember tube assembly on a work bench or stand and using a suitable puller, pull torsion bar spring plate from torsion bar. With spring plate removed, withdraw torsion bar from tube. If rubber mounts in spring plate are damaged, drive from spring plate with a suitable driver (H 103).

Assembly — Apply soapy water to bushing before driving into spring plate. Torsion bars are marked left and right and must be installed accordingly. Install spring plates and tighten bolts when distance "A" (Fig. 2) is 8.46" (215 mm). Install torsion bars, rotating bar a little at a time until bar slides in smoothly.

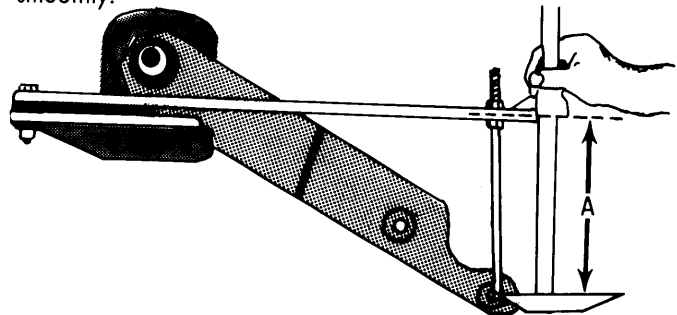

Fig. 2 View Showing Measurement for Spring Plate Installation

Installation — To install crossmember tube and torsion bars, reverse removal procedure.

TIGHTENING SPECIFICATIONS

Application	Ft. Lbs. (mkg)
Upper Shock Absorber Mount	22 (3.0)
Lower Shock Absorber Mount.....	50 (6.9)
Spring Plate-to-Rear Axle	30 (4.1)
Spring Plate-to-Crossmember Tube.....	16 (2.2)
Crossmember Tube-to-Body.....	30 (4.2)
Stabilizer Bar-to-Rear Axle	47 (6.5)
Stabilizer Bar-to-Crossmember Tube.....	29 (4.0)