

## SAAB

99

### DESCRIPTION

Independent front suspension with coil springs. Wheel is supported by steering knuckle mounted between upper and lower control arms by means of ball joints. Both upper and lower control arms pivot on shafts connected to body. Coil springs fit in pockets built into body at top and in supports attached to upper control arms at bottom. Hydraulic shock absorbers mount between lower control arm and body. If stabilizer bar is used, it is attached to frame and connected at ends to lower control arms.

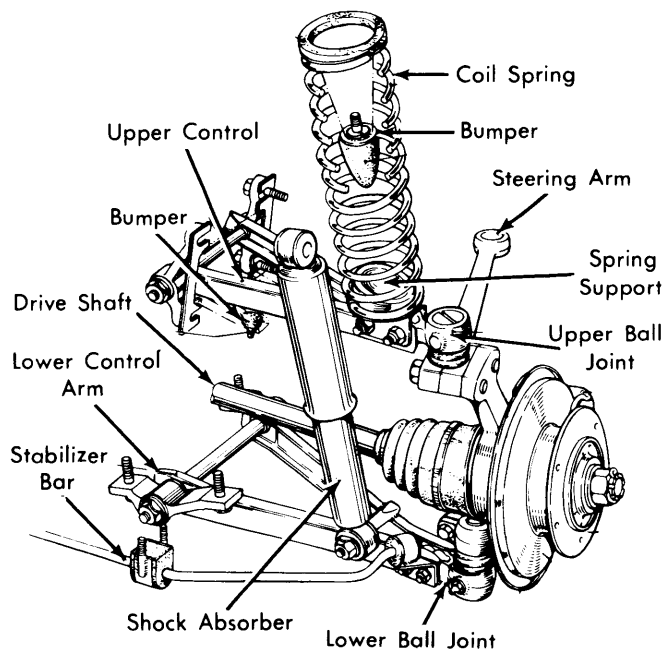

Fig. 1 Saab Front Suspension Assembly

### ADJUSTMENT

#### WHEEL ALIGNMENT SPECIFICATIONS & PROCEDURES

See *Wheel Alignment Specifications and Procedures* in **WHEEL ALIGNMENT** Section.

#### WHEEL BEARING ADJUSTMENT

See *Wheel Bearing Adjustment* in **WHEEL ALIGNMENT** Section.

#### BALL JOINT CHECKING

See *Ball Joint Checking* in **WHEEL ALIGNMENT** Section.

### REMOVAL & INSTALLATION

#### SHOCK ABSORBERS

**Removal** — Raise vehicle and place safety stands under frame. Remove wheel and tire. Remove nuts securing shock absorber and remove shock.

**Installation** — To install, reverse removal procedure.

#### UPPER CONTROL ARM

**Removal** — Raise and support front of vehicle. Remove tire and wheel. Remove shock absorber. Compress coil spring using a suitable compressor (8995839). Remove two bolts attaching upper ball joint to upper control arm. Remove bolts

attaching upper control arm bearing brackets, remove compressed coil spring, upper control arm and bearings. **NOTE** — Save spacers under bearings, and note number of spacers under each reassembly reference.

**Installation** — Replace worn or damaged components. If bearings have been removed from control arm, position onto control arm so when both nuts are tightened and locked, angle between arm and bearing will be  $52^{\circ} \pm 2^{\circ}$ . Install upper control arm but do not install bearing locating bolts. Make sure spacer and support ring of upper spring seat are in position, then locate compressed coil spring with rubber buffer, and mount ball joint and lower spring seat onto control arm. Install bearing attaching bolts while ensuring that spacers are in position. Slowly release compressor tool to release coil spring. Install shock absorber, wheel and tire. Recheck wheel alignment.

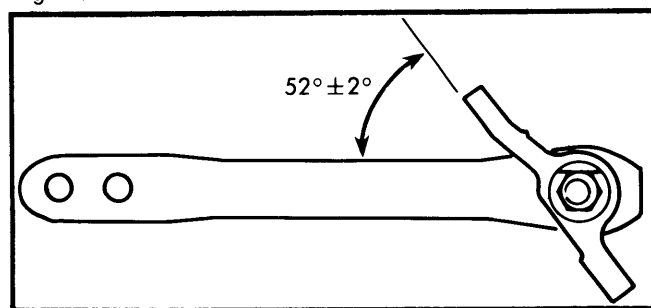

Fig. 2 View Showing Upper Control Arm-to-Bearing Angle

#### LOWER CONTROL ARM

**Removal** — Raise vehicle, then remove wheel and tire. Disconnect shock absorber lower mounting. Remove two bolts attaching lower ball joint to lower control arm. Remove lower control arm-to-engine compartment attaching bolts, then remove lower control arm and brackets.

**Installation** — Replace worn or damaged components. If bearings have been removed from control arm, position onto control arm so when both nuts are tightened and locked, angle between arm and bearing will be  $18^{\circ} \pm 2^{\circ}$ . Install control arm and brackets, attach ball joint to control arm and tighten all attaching bolts. Install wheel and tire. Recheck wheel alignment.

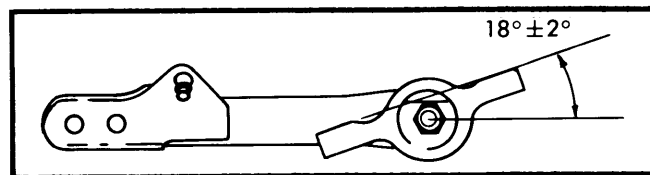

Fig. 3 View Showing Lower Control Arm-to-Bearing Angle

#### COIL SPRING

**Removal** — Raise and support vehicle. Remove tire and wheel. Using suitable spring compressor (8995839) collapse spring approximately  $1\frac{1}{2}$ " (30-40 mm). Remove spring and upper attaching hardware. **NOTE** — Steel cone and other hardware may be stuck in undercoating; use suitable tool to remove.

**Installation** — To install coil springs, reverse removal procedure.