

## LUV

### LUV

#### DESCRIPTION

Independent type suspension, using torsion bars. Upper control arms are mounted to bracket which is part of shock tower. Lower control arm is mounted to crossmember. Ball joints attach both upper and lower control arms to steering knuckles, which are part of the front wheel spindle. Torsion bars are connected in front to lower control arm and at rear to frame crossmember. Back and forth movement of front suspension is regulated by a strut bar connecting lower control arm to frame, by means of a rubber bumper at frame end of strut.

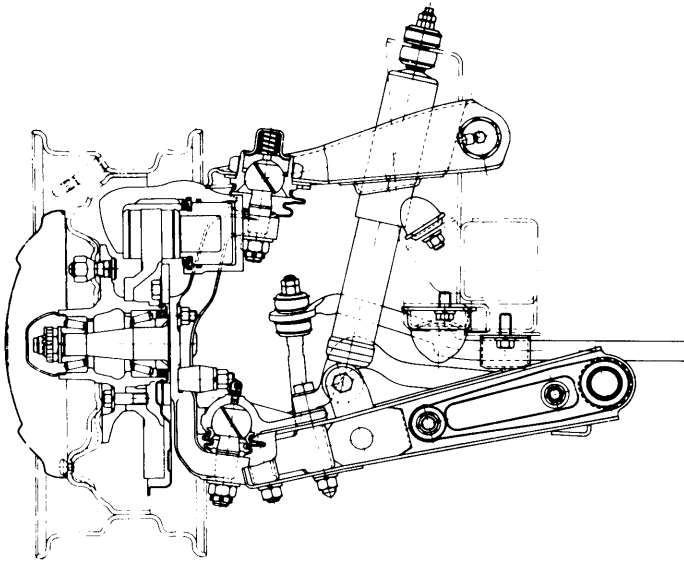

Fig. 1 Sectional View of Front Suspension Assembly

#### ADJUSTMENT

##### WHEEL ALIGNMENT SPECIFICATIONS & PROCEDURES

See *Wheel Alignment Specifications & Procedures* in **WHEEL ALIGNMENT** Section.

##### WHEEL BEARING ADJUSTMENT

See *Wheel Bearing Adjustment* in **WHEEL ALIGNMENT** Section.

##### BALL JOINT CHECKING

See *Ball Joint Checking* in **WHEEL ALIGNMENT** Section.

#### REMOVAL & INSTALLATION

► **INSTALLATION CAUTION** — Fasteners (bushings, washers, bolts and nuts) referred to in all installation procedures, are important attaching parts. Failure of these parts could adversely affect the performance of all suspension components. If necessary that fasteners be replaced, replace with same part number or one of equivalent quality and design. Torque specifications must also be used to insure proper tightening of fasteners.

##### SHOCK ABSORBER

**Removal** — Raise vehicle. Hold shock absorber upper stem with a wrench and remove retaining nut, retainer and rubber

grommet. Remove lower shock absorber pivot bolt from lower control arm and remove shock absorber.

**Installation** — Check shock absorber and replace if necessary. Fully extend shock absorber, place lower retainer and grommet on stem and slide shock absorber into position. Install upper grommet and retainer on stem and tighten nut to specification. Slide bolt thru lower shock absorber mount and shock absorber. Tighten bolt to specification and lower vehicle.

##### LOWER CONTROL ARM STRUT BAR

**Removal** — Raise vehicle and remove double nuts, washers and rubber bushings from front side of strut bar. Remove two bolts holding strut bar to lower control arm and remove strut bar.

**Installation** — Place washer and bushing on strut bar and slide rod through frame bracket. Place second set of washers and bushings on end through bracket, then start on washer and one nut, but do not tighten. Bolt other end of strut to lower control arm and tighten to specifications. Lower vehicle and tighten bracket nut, install second nut and tighten to specifications.

##### STABILIZER BAR

**Removal** — Raise vehicle and disconnect stabilizer bar from lower control arm. Remove brackets holding bar to frame and remove bar. Remove link bolt, spacers and rubber grommets from lower control arm or stabilizer bar. Inspect all parts for wear or damage and replace if necessary.

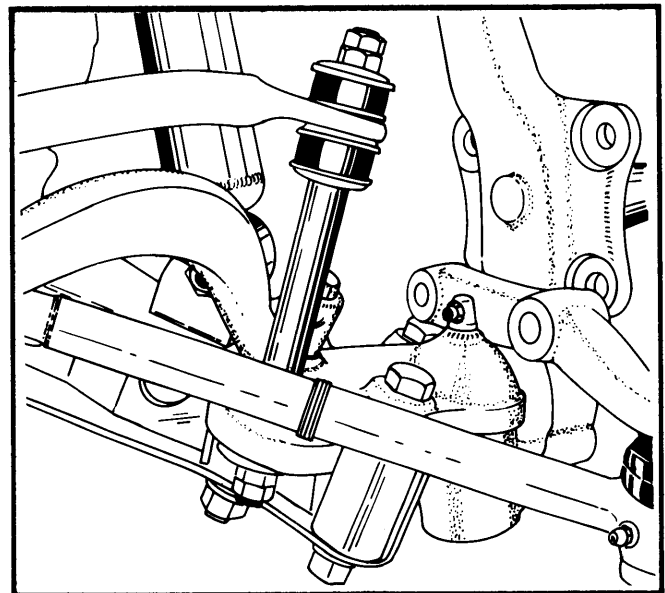

Fig. 2 Detail of Stabilizer Bar Link Bolt Installation

**Installation** — Bolt brackets to frame over rubber bushings installed over stabilizer bar but do not tighten. Connect link bolts to lower control arm, making sure washers are installed in correct position. Connect link bolts to stabilizer, and tighten to specifications. Tighten bracket bolts to specifications.

##### UPPER CONTROL ARM & BALL JOINT

**Removal** — Raise vehicle and place safety stands under lower control arm. Remove tire and wheel. Remove upper ball joint cotter pin and nut. Disconnect spindle from upper control arm.

## LUV (Cont.)

**CAUTION** — Do not let spindle and brake assembly hang from brake flex line, wire assembly to frame. Remove two bolts holding upper control arm to bracket. Remove control arm from vehicle. Note the position and number of shims to keep correct caster and camber when installing control arm. If pivot shafts or bushings are to be removed, alternately loosen bushing nuts from pivot shaft and remove shaft from control arm. Check control arm and pivot shaft for cracks or distortion. Replace both pivot shaft and bushings if either are found defective. Replace rubber boots if necessary. Ball joint and control arm are a complete assembly. If ball joint needs replacing, entire control arm must be replaced.

**Installation** — Install boots on upper control arm pivot shaft. Pack inside of bushings with molybdenum disulfide grease and alternately screw right and left bushings into pivot shaft. Use a suitable tool to space pivot shaft when tightening bushings. Avoid getting grease on outer bushing face. Tighten bushings to specifications. Install grease fittings and grease all parts thru fittings. Place ball joint stud thru spindle. Install castellated nut and tighten to specifications. Install new cotter pin, if it does not align, tighten nut just enough for cotter pin to slide in.

**NOTE** — Do not loosen nut to allow cotter pin to be installed. Install upper control arm to chassis frame, making sure shims

equal in thickness to those that were removed, are installed. Tighten bolts to specifications. **NOTE** — For better pivot shaft to frame retention, tighten thinner shim packs first. Install dust cover, tire and wheel and lower vehicle.

### LOWER CONTROL ARM & BALL JOINT

**Removal** — Raise vehicle and place safety stand under frame. Remove tire and wheel. Remove strut bar, torsion bar and disconnect stabilizer bar as previously outlined. Disconnect lower end of shock absorber. Remove cotter pin and nut retaining lower ball joint to spindle. Remove lower control arm retaining nuts and remove control arm. Ball joint can be removed with control arm either installed or out of vehicle, by removing two bolts retaining ball joint to control arm.

**Installation** — Check all parts for distortion, cracking or excessive wear. If ball joint was removed, install ball joint in lower control arm and tighten bolts to specification. Bolt lower control arm to chassis and tighten to specification. Place ball joint stud in spindle, tighten nut to specification, and install new cotter pin. **NOTE** — Do not loosen nut to allow cotter pin to be installed. Install torsion bar, strut bar and stabilizer bar as previously outlined. Install tire and wheel and lower vehicle.

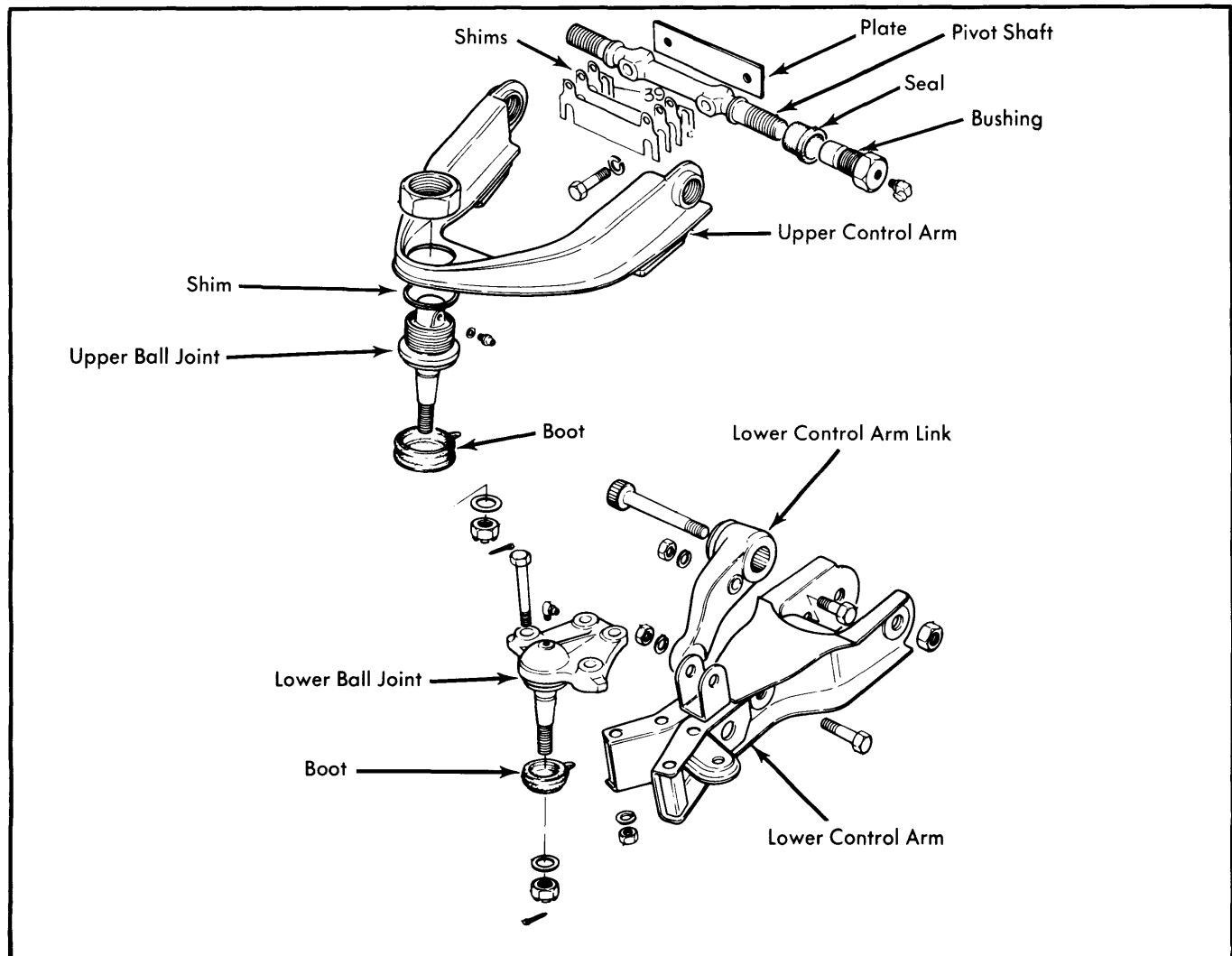

Fig. 3 Exploded View of LUV Front Suspension Assembly

# Front Suspension

## LUV (Cont.)

### TORSION BAR

**Removal** — Raise vehicle and place safety stands under front of vehicle. Mark position of height control arm adjusting bolt, then remove bolt. Remove height control arm from torsion bar and crossmember. Mark position, then remove torsion bar from lower control arm.

**Installation** — Thoroughly grease serrated portions at both ends of torsion bar. Raise lower control arm with a jack to position rubber bumpers in contact with lower control arm. Install front end of torsion bar into control arm. Install height control arm into position so its end is reaching the adjusting bolt. **NOTE** — Grease portion of height control arm which fits into frame. Turn height control adjusting bolt to position marked upon disassembly. Check riding height. See *Wheel Alignment Specifications and Procedures in WHEEL ALIGNMENT Section.*

### STEERING KNUCKLE

**Removal** — Raise vehicle and place safety stands under front of vehicle. Remove tire and wheel. Disconnect brake hose from wheel cylinder. Remove dust cap, cotter pin, nut retainer, and spindle nut. Remove brake drum. Remove two bolts attaching tie rod end link, and position link to one side. Remove remaining two bolts, then remove brake backing plate assembly. Remove cotter pins and attaching nuts for upper and lower ball joints. Disconnect knuckle from ball joints, then remove steering knuckle from vehicle.

**Installation** — To install, reverse removal procedures while noting the following: Adjust wheel bearings. Bleed brakes after connecting brake hose to wheel cylinder. Tighten all bolts to specifications.

TIGHTENING SPECIFICATIONS	
Application	Ft. Lbs. ( mkg)
<b>Backing Plate-to-Knuckle</b>	
Small Bolts .....	35(4.8)
Large Bolts .....	50(6.9)
Ball Joint-to-Lower Control Arm .....	45(6.2)
Ball Joint Stud Nut .....	75(10.4)
<b>Control Arm Pivot-to-Frame</b>	
Lower .....	130(18.0)
Upper .....	50(6.9)
Lower Control Arm-to-Crossmember .....	130(18.0)
<b>Shock Absorber</b>	
Lower End .....	45(6.2)
Upper End .....	18(2.5)
<b>Stabilizer Bar</b>	
Nuts .....	7(1.0)
Lock Nuts .....	18(2.5)
<b>Strut Bar-to-Frame</b>	
Nut .....	15(2.1)
Lock Nut .....	50(6.9)
Strut Bar-to-Lower Control Arm .....	45(6.2)
Upper Control Arm Shaft Bushings .....	220(30.4)