

## RENAULT (Cont.)

2) With caster angle determined, loosen both lower control arm mounting bolts. Add or remove caster shims to bring adjustment within specifications. One shim is equal to about 1°.

**NOTE** — Never use more than two shims between bushing and side member. Always check steering box height after adjustment.

### Caster Angle Table

Subtracted Value	Caster Angle
1 $\frac{1}{16}$ " (40 mm).....	12 $\frac{1}{2}$ °
2 $\frac{3}{8}$ " (60 mm).....	12°
3 $\frac{1}{8}$ " (80 mm).....	11 $\frac{1}{2}$ °
3 $\frac{5}{16}$ " (100 mm).....	11°
4 $\frac{3}{4}$ " (120 mm).....	10 $\frac{1}{2}$ °
5 $\frac{1}{2}$ " (140 mm).....	10°

### CAMBER

Camber angle is not adjustable. If not within specifications, inspect front suspension for wear or damage and repair or replace components as necessary.

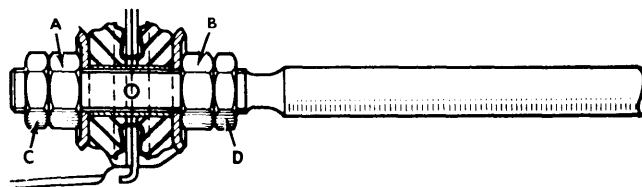

Fig. 2 Caster Adjustment Points at Tie Rod Mounting  
All Models Except R-5

### TOE-IN

If toe-in is not to specifications, disconnect steering arm at rack end. Loosen lock nut on steering end fitting. To increase toe-in, unscrew end fitting. To decrease, screw in fitting. Tighten lock nut and connect steering arm. Recheck toe-in.

## SAAB

### ADJUSTMENT

#### TIRE INFLATION (COLD)

Before attempting to check or adjust wheel alignment, make sure tires are properly inflated. Refer to manufacturers specifications given in owner's manual.

#### CASTER

**All Models** — To adjust caster, add or remove shims under upper control arm bushing brackets. Changing shims from front to rear bracket increases caster angle. Moving shims from rear to front decreases caster angle. **NOTE** — Same thickness of shims removed from front must be placed under rear and vice versa. Change in caster also effects camber.

#### CAMBER

**All Models** — To adjust camber, add or remove shims under upper control arm bushing brackets. Increasing shims under both brackets reduces camber angle and removing shims under both increases camber. **NOTE** — Always add or remove same thickness of shims at front and rear or caster angle will be affected.

### TOE-IN

**All Models** — With wheels in straight-ahead position, loosen steering link (tie rod) lock nut and turn adjustable sleeve until correct toe-in is obtained. Tighten lock nuts and recheck toe-in.

**NOTE** — After adjustment of toe-in, measurement "A" (Fig. 1) of tie rod must not exceed 1.0" (25 mm). For tie rods opposite to each other, the difference between measurement "A" must not exceed .08" (2 mm).

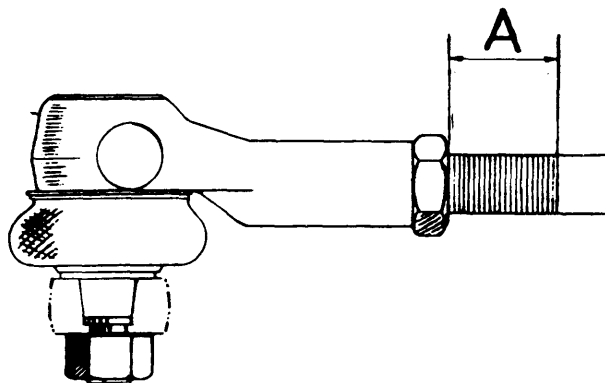

Fig. 1 View Showing Where to Measure Tie Rod Length

## SUBARU

### ADJUSTMENT

#### TIRE INFLATION (COLD)

Before attempting to check or adjust wheel alignment, make sure tires are properly inflated. Refer to manufacturers specifications given in owner's manual.

### RIDING HEIGHT (REAR)

Riding height is adjusted by changing the size of the angle between trailing arm center line and the markings on outer bracket. See Fig. 7. The trailing arm and outer bracket have full serrations around the torsion bar mounting hole, while torsion bar has one missing serration, thus allowing torsion bar to be inserted at any angle.

# Wheel Alignment

## SUBARU (Cont.)

Raising vehicle height is accomplished by turning outer end and inner end of torsion bar in direction opposite to cast-in arrow on outer end of bar. Height changes .20" (5mm) per each serration shifted.

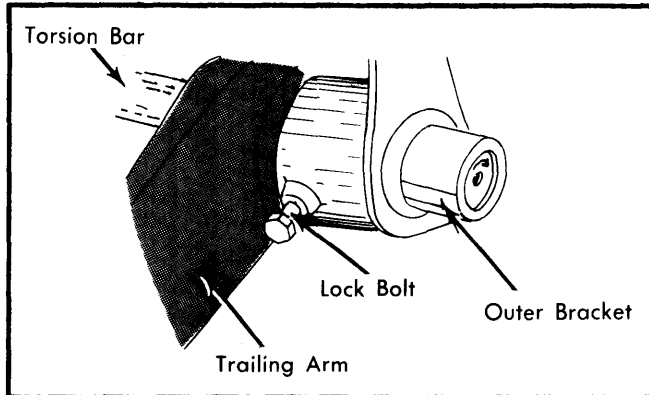

Fig. 1 Installed View of Torsion Bar Outer End Attachment

1) Initially set vehicle rear riding height by inserting torsion bar with its missing serration aligned with markings on outer bracket surface and trailing arm inner surface. This will give approximately the specified riding height as indicated in table.

2) Measure road clearance from center of trailing arm arm bushing to ground. **NOTE** — Vehicle must be in unloaded condition. Raise rear of vehicle and remove rear wheel.

3) Unscrew shock absorber lower mounting nut and remove it from trailing arm. Unscrew lock bolt on outer bushing.

4) Scribe mark position of torsion bar by making a mark on upper half of inner end surface and lower half of outer end surface. Outer end surface mark should be continued onto trailing arm shaft and outer bracket boss.

5) Holding trailing arm so torsion bar does not twist, disengage serrations by tapping inner end surface of torsion bar See Fig. 2.

6) Pull torsion bar out of trailing arm. Determine amount of turn necessary to make proper height adjustment and turn inner end of torsion bar to this value. Then, insert outer end of torsion bar to its proper adjusted position.

7) Install rear wheel and lower vehicle. Reattach lower end of shock absorber. Recheck vehicle rear ground clearance as originally measured. If correct, tighten lock bolt on outer trailing arm bushing. If incorrect, repeat adjustment.

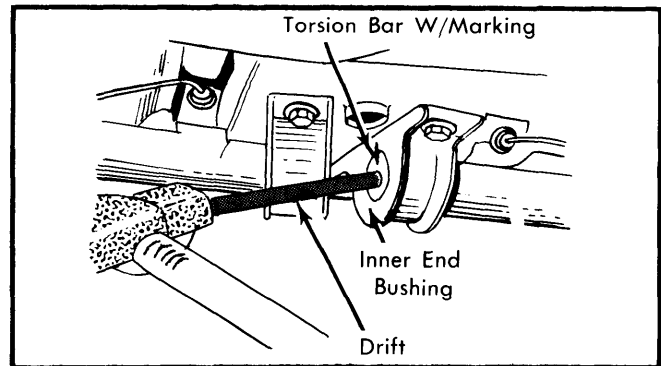

Fig. 2 View Showing Removal Procedure For Torsion Bar

### Rear Riding Height Specifications

Application	Height
1400	
Sedan.....	11.34-11.89" (288-302 mm)
Station Wagon.....	12.21-12.76" (310-324 mm)
4WD Station Wagon.....	14.17-14.76" (360-375 mm)

### CASTER

Caster angle is not adjustable. If angle is not to specifications, inspect suspension for wear or damage and repair or replace components as necessary.

### CAMBER

**All Models (Front)** — Camber angle is not adjustable. If angle is not to specifications, inspect suspension for wear or damage. Repair or replace components as necessary.

**All Models (Rear)** — Camber angle is adjusted by altering number of shims inserted between torsion bar bracket and chassis mounting. Fitting shims changes camber to negative and removing shims changes camber to positive. One shim corresponds to  $\frac{1}{4}^{\circ}$  adjustment.

### TOE-IN

**All Models (Front)** — If toe-in is not within specifications, loosen steering link (tie rod) lock nut and turn sleeve until correct toe-in is obtained.

**All Models (Rear)** — If toe-in is not within specifications, loosen bolts holding torsion bar bushing to body. Bushing is fixed to body at elongated holes. Moving bushing forward decreases toe-in and moving it rearward increases toe-in. Tighten bolts and recheck toe-in.

## TOYOTA

### ADJUSTMENT

#### TIRE INFLATION (COLD)

Before attempting to check or adjust wheel alignment, make sure tires are properly inflated. Refer to manufacturers specifications given in owner's manual.

### RIDING HEIGHT

**Corona and Mk II** — Place vehicle on level surface. Bounce several times and allow suspension to settle. Check riding height dimensions (See Fig. 1) and if not within specifications, inspect suspension components. Replace or repair parts as required.