

VOLKSWAGEN

Type 1
Type 2
Dasher
Rabbit
Scirocco

DESCRIPTION

Brake system is hydraulically actuated, using a tandem master cylinder and on some models, a power brake unit. Type 1 models are equipped with drum brakes on all four wheels. All other models are equipped with disc brakes on the front wheels and drum brakes on the rear wheels. All models with disc brakes are equipped with a pressure regulator in the rear brake circuit. The pressure regulator limits pressure to the rear brakes when foot brake is applied, preventing rear wheel lock-up. All models are equipped with a mechanical parking brake, operating on the rear brakes.

ADJUSTMENT

DISC BRAKES

Disc brakes are self-adjusting; therefore, no adjustment in service is required.

DRUM BRAKES

Type 2 (Rear Brakes) — Turn adjusting nut for both shoes three notches at a time, alternating from one nut to the other, until both shoes are rubbing on brake drum. Turn both nuts back alternately, until brake drum just rotates freely.

All Others — Turn adjuster until a slight drag is felt when rotating brake drum. Back off adjuster 3-4 notches, or until drum is just free to rotate.

PARKING BRAKE

Type 2 & Dasher — Raise and support vehicle and ensure rear brakes are properly adjusted. From under vehicle, loosen parking brake cable lock nut(s). Pull parking brake handle up six notches (Type 2), or two notches (Dasher) and tighten cable adjusting nut(s) until rear wheels can just be turned by hand. Tighten lock nut(s) and ensure rear wheels rotate freely with parking brake fully released.

All Others — Raise and support vehicle and ensure rear brakes are properly adjusted. Pull back rubber (plastic) boot at base of parking brake handle and loosen parking brake cable lock nuts. Pull handle up three notches and tighten each adjusting nut until rear wheels just lock. Tighten lock nuts and refit rubber (plastic) boot. Ensure rear wheels rotate freely with parking brake fully released.

HYDRAULIC SYSTEM BLEEDING

Pressure Bleeding — Attach bleeder connector cap to cylinder reservoir, and pressurize system to 43 psi. Attach one end of bleeder tube to cylinder bleeder screw, and submerge opposite end of tube in a jar half full of clean brake fluid. Open each bleeder screw in turn, and allow fluid to flow into container until fluid flows with no sign of air in fluid.

Manual Bleeding — Attach one end of bleeder tube to bleeder screw, and submerge opposite end in a jar half full of clean brake fluid. Pump brake pedal several times, and with pedal at bottom of stroke, open bleeder screw. Close bleeder screw, then release pressure on brake pedal. Repeat procedure until fluid flows from bleeder tube with no sign of air in fluid.

REMOVAL & INSTALLATION

FRONT DISC BRAKE PADS

Removal, Girling — Raise and support vehicle, remove wheel. Pry off caliper spreader spring. Remove spring retainer bolt. Using pliers, pull out pad retainer pins. With a disc pad extractor tool, pull out pads. Inspect disc pads for wear or damage. Replace pads if lining thickness is less than .080" (2.0 mm).

Installation — To install Girling disc brake pads, reverse removal procedure and note: Tighten spring retainer bolt. Make sure spreader spring arrow faces upward.

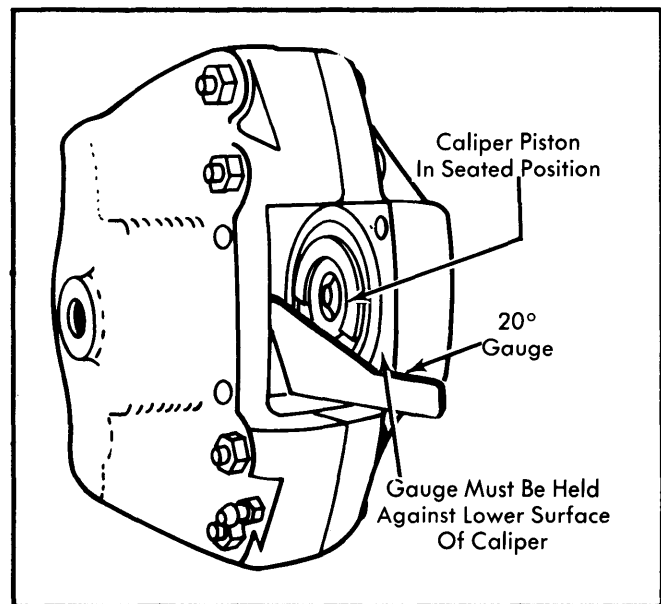

Fig. 1 Using a 20° Gauge to Properly Position Piston

Removal, ATE — Raise and support vehicle, remove wheel. Remove spring clips from retaining pins. Using a punch, drive out retaining pins. Remove damper spring. With a disc pad extractor tool, remove inner pad. Outer pad is positioned in a notch and must be moved out of notch before removal. Inspect disc pads for wear or damage. Replace pads if lining thickness is less than .080" (2.0 mm). Remove piston retaining plate and clean in denatured alcohol. Inspect plate for damage and replace as necessary.

Installation — Using a suitable piston retaining device, push piston to bottom of cylinder bore. Check position of piston using a 20° gauge. Install piston retaining plate, insert disc pads and a NEW damper spring. Using a hammer, install retaining pins into caliper. Depress brake pedal several times to seat pistons and disc pads.

VOLKSWAGEN (Cont.)

DISC BRAKE CALIPER

Removal — Raise and support vehicle and remove wheel. Disconnect brake line from caliper and plug opening to prevent entry of dirt and foreign matter. Bend back locking tabs on mounting bolts at steering knuckle. Remove caliper mounting bolts and remove caliper assembly from vehicle.

Installation — To install, reverse removal procedure, using new lock plates and mounting bolts.

DISC BRAKE ROTOR

Removal — Raise and support vehicle, remove wheel. Remove caliper mounting bolts and hang caliper from tie rod with wire. Remove wheel bearing mounting hardware and carefully pull hub and rotor assembly (with outer bearing) from spindle. **NOTE** — On Type 2 models, if hub is stuck, DO NOT pound with hammer, screw bolts into three holes provided until assembly breaks loose. Rotor can be separated from hub by removing the Allen head bolts.

Installation — To install hub and rotor assembly, reverse removal procedure and adjust wheel bearings. See *Wheel Bearing Adjustment* in WHEEL ALIGNMENT Section.

FRONT BRAKE DRUM

Removal — Raise and support vehicle, and remove wheel. Remove retainer from speedometer cable. Remove dust cap from hub, then remove wheel bearing adjusting nut, and outer wheel bearing. Back off brake shoe adjusters, and remove hub and drum assembly from vehicle.

Installation — To install, reverse removal procedure. Adjust and lubricate wheel bearings, and adjust brake shoes.

REAR BRAKE DRUM

Removal (Type 1) — Remove cotter pin and castellated nut. Loosen castellated nut while vehicle is on ground. Raise and support vehicle, then take off wheel. Release parking brake and back off adjusters. Fit puller to drum and take off drum.

Installation — To install, reverse removal procedure and note: Make sure castellated nut is tightened with vehicle on floor.

Removal (Type 2) — Raise and support vehicle, remove wheel. With parking brake released, back off on brake shoe adjuster. Remove two Allen head screws and pull brake drum from wheel hub.

Installation — To install, reverse removal procedure and make sure Allen head screws are tight.

Removal (Rabbit, Scirocco, Dasher) — Raise and support vehicle. Back off brake shoe adjusters. Remove grease cap and cotter pin. Loosen, then remove adjustment nut and washer. Slide drum off spindle being careful not to drop outer bearing.

Installation — To install, reverse removal procedure and note: Clean spindle and threads. Make sure wheel bearing is lubricated. Adjust wheel bearings. See *Wheel Bearing Adjustment* in WHEEL ALIGNMENT Section. Adjust brake shoes.

BRAKE SHOES

Removal (Front) — Raise and support vehicle. Remove wheel, and brake drum. Remove brake shoe hold down pins and springs. Remove brake shoe return springs, and pry shoes from adjusting screws. Remove brake shoes from vehicle.

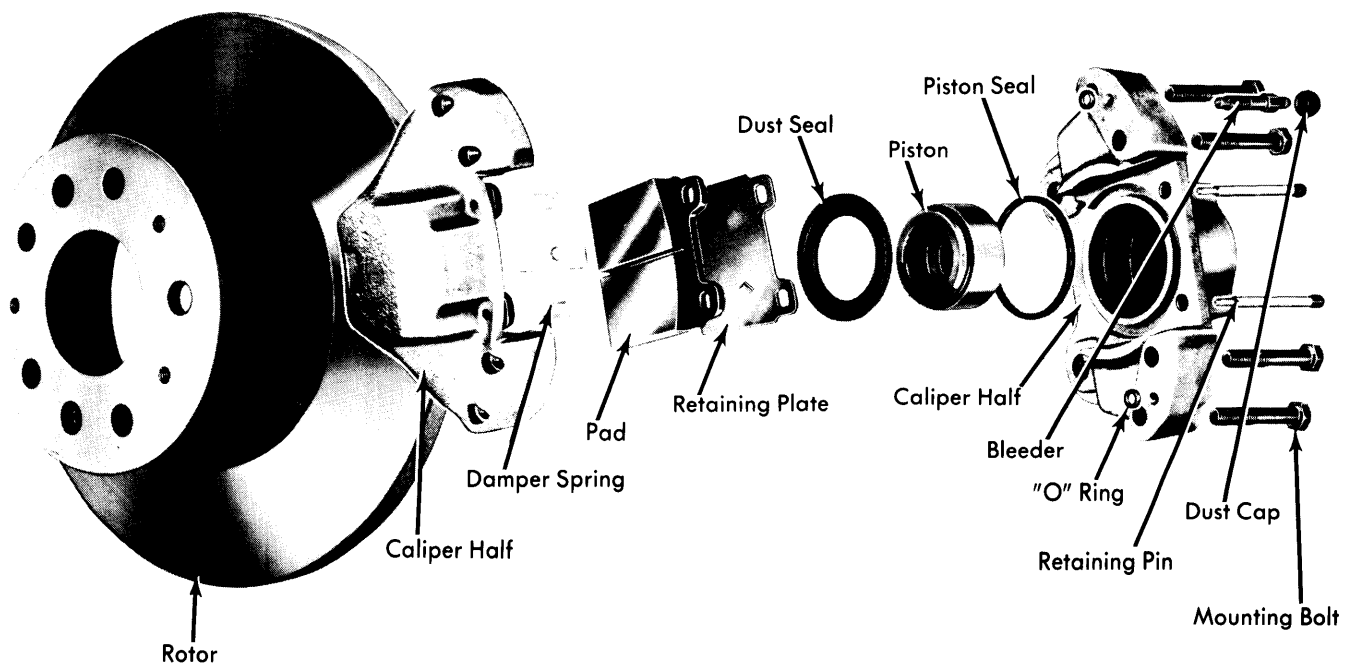

Fig. 2 Volkswagen Type 2 Front Disc Brake Assembly

VOLKSWAGEN (Cont.)

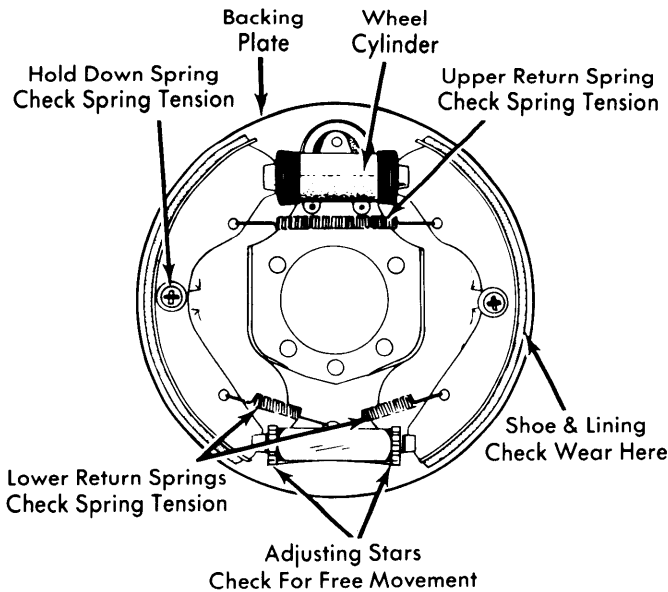

Fig. 3 Volkswagen Type 1 Front Brake Assembly

Removal (Rear) — Raise and support vehicle. Remove wheel, and brake drum. Remove brake shoe hold down pins and springs. Remove lower shoe return spring, and disconnect parking brake cable from lever. Remove brake shoes, connecting link, upper return spring, and clip from vehicle as an assembly. Separate shoes from attaching hardware.

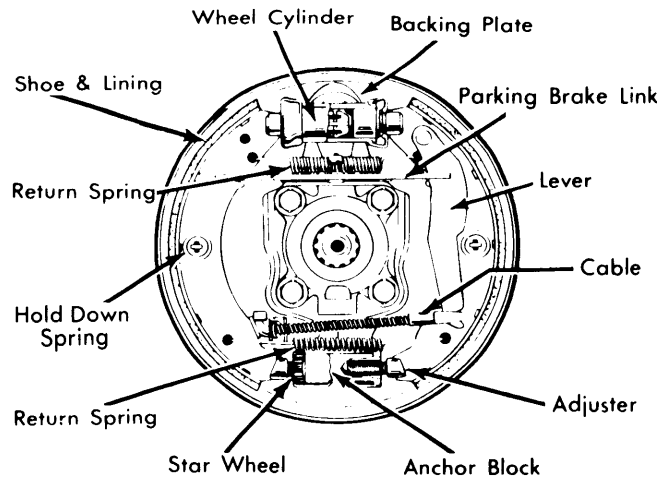

Fig. 4 Volkswagen Type 2 Rear Brake Assembly

Installation (All Models) — To install reverse removal procedure. Adjust brakes and bleed hydraulic system if necessary.

MASTER CYLINDER

NOTE — Removal and installation of all master cylinders is basically the same. The following variations may apply: Location of cylinder, removal of wheel for accessibility, number of fluid connections, and number of electrical connections.

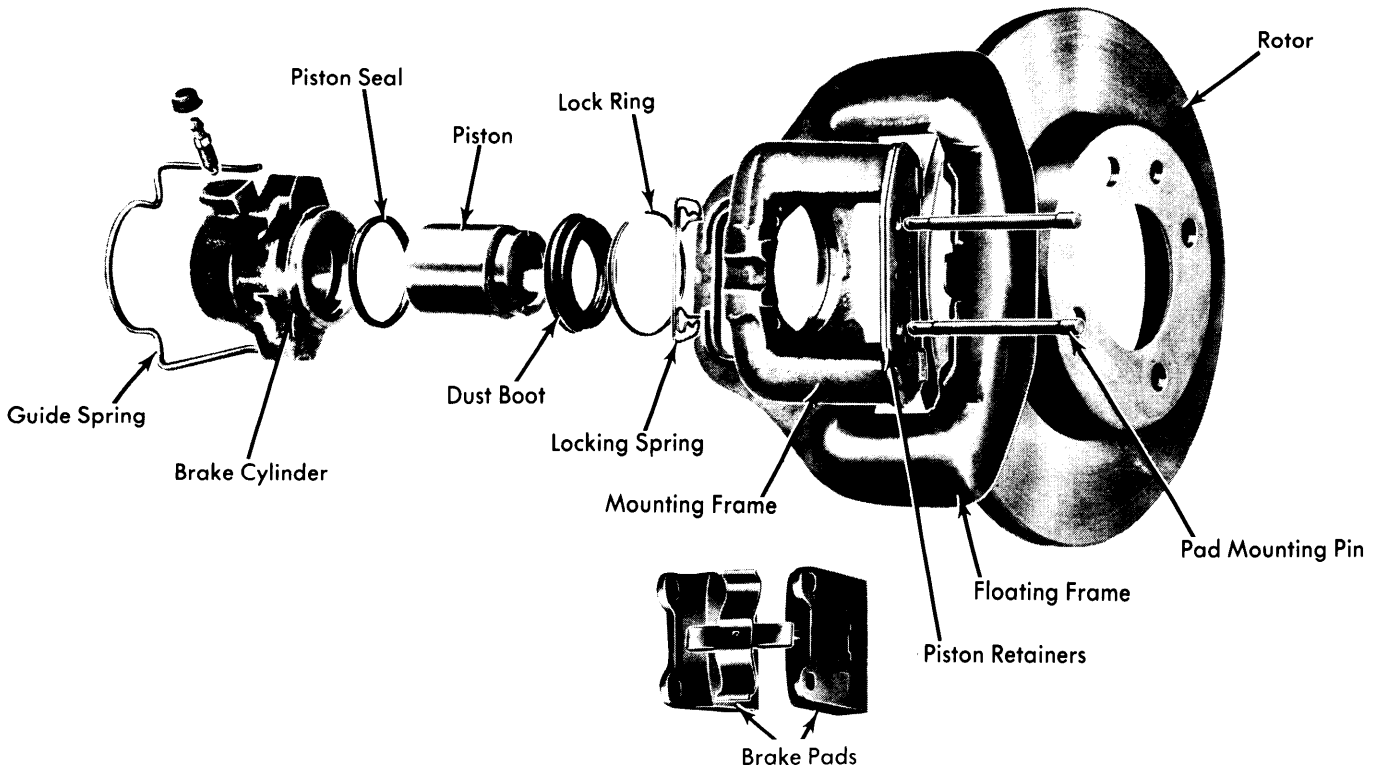

Fig. 5 Exploded View of ATE Disc Brake Assembly — Rabbit, Scirocco, Dasher

VOLKSWAGEN (Cont.)

Removal — Drain or siphon fluid from reservoir(s). Raise and support vehicle, and remove cover plate (if equipped). Disconnect fluid lines at master cylinder. Disconnect electrical connections at cylinder, and remove push rod at brake pedal connection. Remove master cylinder attaching bolts, and remove master cylinder from vehicle. **NOTE** — *If spacers are used on attaching bolts, do not allow spacers to drop into pedal assembly recess.*

Installation — To install, reverse removal procedure and note the following: On vehicles equipped with a power brake unit, install a new "O" ring seal between master cylinder and power unit. After installation, bleed hydraulic system.

POWER BRAKE BOOSTER

Removal & Installation — Remove master cylinder from power brake unit. Remove vacuum hoses and cover plate, then back off push rod lock nut at power booster end. Disconnect push rod at brake pedal, pull rod to one side, and unscrew push rod from booster. Remove booster attaching hardware, and pull booster out and back. To install booster, reverse removal procedure.

OVERHAUL

DISC BRAKE CALIPER

Disassembly, Type 2 — Remove disc pads and retaining plates from caliper assembly, then clamp mounting flange in a vise. Remove retainer and dust seal from caliper assembly. Install a piston retaining tool on one piston and a thin block of wood between tool and piston to be removed. Carefully apply air pressure to fluid inlet port and remove piston. Remove piston seal from groove with a pointed tool.

Inspection — Clean all parts in brake fluid. Check piston and caliper bore for wear or damage; replace as necessary. **NOTE** — *Manufacturer recommends replacing rubber parts during caliper overhaul.*

Reassembly — Apply light coat of brake paste to piston and seal. Fit seal in groove. Install piston and clamp at bottom of bore. Lightly coat inside of dust seal with paste and fit to piston. Using suitable tool (VW 442), press seal and piston into caliper. Fit retaining plate and position piston in bore. Repeat procedure on other half of caliper.

Disassembly; Rabbit, Scirocco, Dasher (ATE) — Remove disc pads. Pry mounting frame and piston assembly off floating frame. Separate guide spring and brake cylinder. Remove clamp and dust cap from brake cylinder, then withdraw piston. Compressed air may be used to force out piston.

Inspection — Clean all parts in brake fluid. Check piston and caliper bore for damage or wear; replace as necessary. **NOTE** — *Manufacturer recommends replacing all rubber parts during overhaul.*

Reassembly — To reassemble, reverse disassembly procedure and note following: Coat piston with brake paste. Use a vise to seat piston. Use a brass drift to fit brake cylinder to floating

frame. Make sure two grooves in mounting frame are pushed over ribs on floating frame. Ensure piston is in proper position.

Disassembly, Dasher (Girling) — Press brake cylinder out of yoke. Hold brake cylinder between two jaws of a vise with a slight gap. Blow compressed air into fluid port and force out pistons. With a pointed tool, remove sealing rings.

Inspection — Clean all parts in brake fluid. Check piston and caliper bore for damage or wear; replace as necessary. **NOTE** — *Manufacturer recommends replacing all rubber parts at time of overhaul.*

Reassembly — To reassemble, reverse disassembly procedure and note: Coat pistons and seals with brake paste before refitting.

WHEEL CYLINDER

Disassembly — With wheel cylinder removed from vehicle, remove dust boot(s), piston(s), expander spring, and cups.

Inspection — Clean all parts with clean brake fluid or denatured alcohol. Check piston and cylinder bore for out-of-round, corrosion, or damage.

Reassembly — To reassemble, reverse disassembly procedure, using new rubber components. Replace piston(s) and spring as necessary. Use brake cylinder paste on pistons and cups.

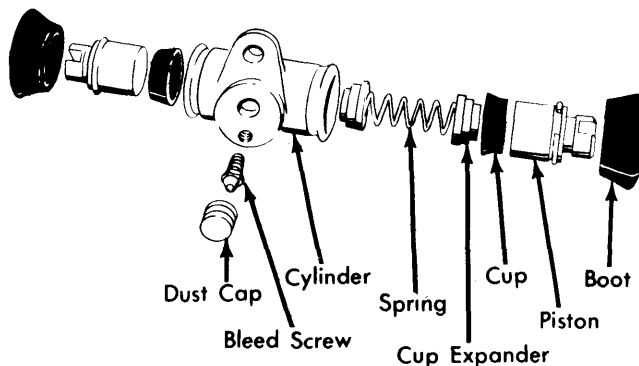

Fig. 6 Volkswagen Type 1 Wheel Cylinder Exploded View

MASTER CYLINDER

Disassembly — Remove front brake circuit piston stop screw. On Type 2 vehicles with power booster, remove snap ring and stop washer. On all other models, remove dust boot, stop ring, and stop washer. Remove both pistons and springs from cylinder by tapping open end of cylinder on a wood surface, or by carefully applying air pressure to front brake circuit fluid port with all other openings plugged. Remove all externally mounted fittings and switches from cylinder housing.

Inspection — Clean all parts with clean brake fluid or denatured alcohol. Check all pistons and cylinder for out-of-round, corrosion, or damage. If light honing will not remove blemishes from cylinder, replace cylinder. Inspect all other parts for scoring, wear, corrosion, or other damage.

VOLKSWAGEN (Cont.)

Reassembly — 1) Install cups on pistons. Place cup washer, primary cup, support washer, spring retainer, and spring onto front piston, and insert piston assembly into cylinder bore. Assemble cup washer, primary cup, support washer, spring retainer, spring, and stop sleeve onto rear piston. Secure assembly with stroke limiting screw.

2) Except on Type 2 vehicles with power booster, install rear piston assembly into cylinder. Install stop washer, and locking ring. On Type 2 vehicles with power booster, install rear piston with washer, cup, plastic washer, second cup, and second washer into cylinder, followed by snap ring.

3) Install piston stop screw, pushing front piston assembly forward as required to clear stop screw hole. Install all externally mounted switches and fittings. Tighten all nuts and bolts.

POWER BRAKE UNIT & PRESSURE REGULATING VALVE

Replace these units as an assembly, do not try to overhaul units. When installing booster, use new boot, filter, damping washer, and sealing ring.

TIGHTENING SPECIFICATIONS

Application	Ft. Lbs. (mkg)
Master Cylinder-to-Booster	9 (1.3)
Master Cylinder-to-Frame	18 (2.5)
Piston Stop Screw	4-7 (.5-1.0)
Stop Light Switch	14 (2)
Caliper Mounting Bolts	
Type 2	116 (16)
Dasher, Rabbit, Scirocco.....	43 (6)
Slotted Axle Nut	253 (35)

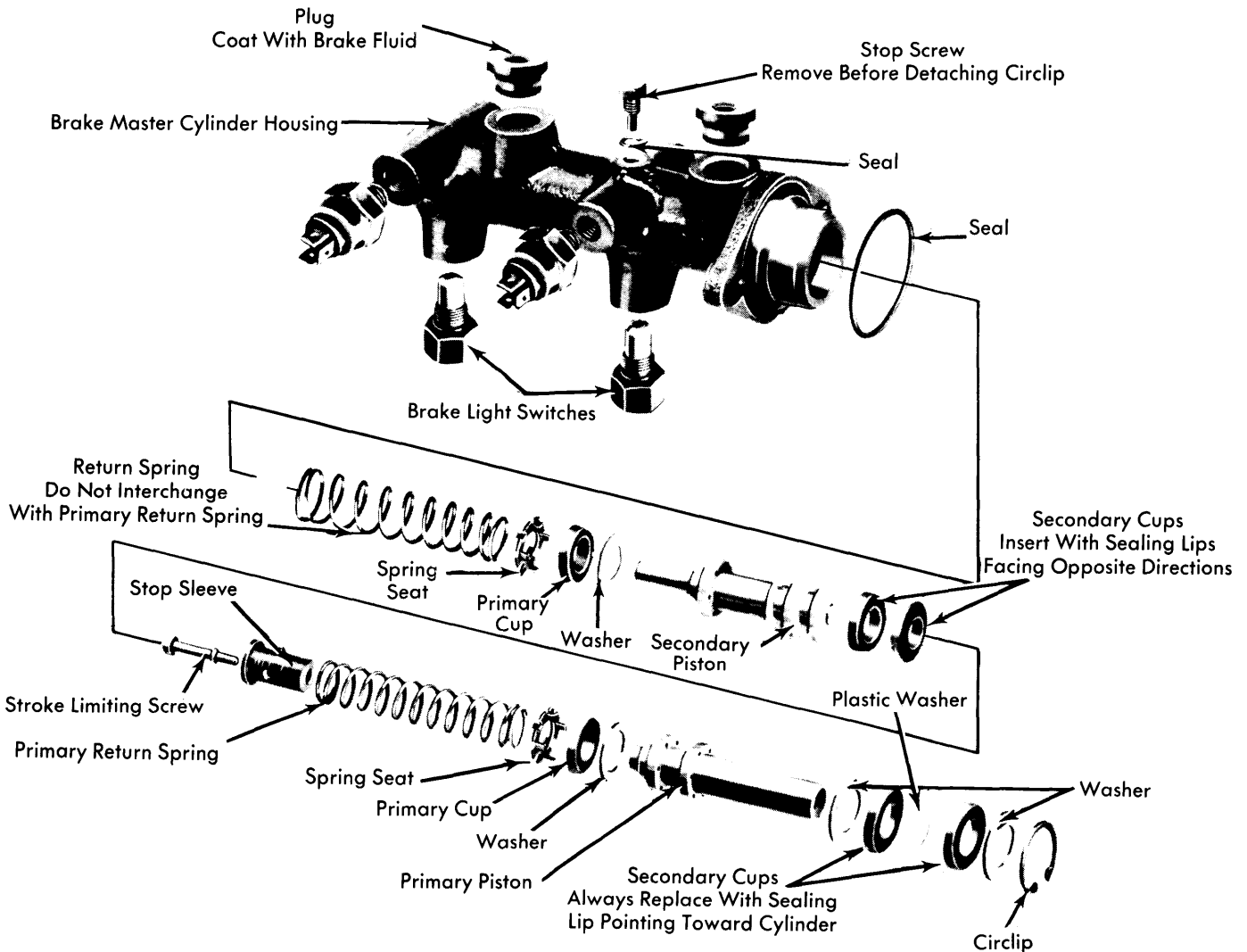

Fig. 7 Master Cylinder Component Relationship — Rabbit, Scirocco, Dasher

VOLKSWAGEN (Cont.)

BRAKE SYSTEM SPECIFICATIONS				
Application	Drum Diam. In. (mm)	Wheel Cylinder Diameter		Master Cylinder Diameter In. (mm)
		Front In. (mm)	Rear In. (mm)	
Type 1	9.055 (230)	.874 (22.2)	.678 (17.5)	.750 (19.05)
Type 2	9.921 (252)	2.126 ^① (54)	.937 (23.8)	.874 (22.2)
Dasher	7.87 (200)	①813 (20.6)
Rabbit & Scirocco	7.1 (180)	①

① — Front disc brakes.

DISC BRAKE ROTOR SPECIFICATIONS ①						
Application	Disc Diameter	Lateral Runout	Parallelism	Original Thickness	Minimum Refinish Thickness	Discard Thickness
Type 2	10.95 (278)	.004 (.10)	.0008 (.02)	.512 (13)	.472 (12)	.452 (11.5)
Dasher	9.41 (239)	.004 (.10)	.0008 (.02)	.472 (12)	.433 (11)	.410 (10.5)
Rabbit & Scirocco472 (12)	.433 (11)	.410 (10.5)

① — In. (mm)

BRAKE DRUM SPECIFICATIONS				
Application	Drum Diameter In. (mm)	Original Diameter In. (mm)	Maximum Refinish Diameter In. (mm)	Discard Diameter In. (mm)
Front Type 1	9.055 (230)	9.055 (230)	9.114 (231.5)
Rear Type 1	9.055 (230)	9.055 (230)	9.114 (231.5)
Type 2	9.921 (252)	9.921 (252)	9.980 (253)
Dasher	7.87 (200)	7.87 (200)	7.89 (200.5)	7.91 (201)
Rabbit & Scirocco	7.08 (180)	7.08 (180)	7.10 (180.5)	7.125 (181)