

BMW 6 CYLINDER

3.0
530i

DESCRIPTION

Brake system is hydraulically actuated, using a tandem master cylinder and a power brake unit. All models use four wheel ATE disc brakes. Front brakes are four piston caliper type and the rear use two piston fixed caliper type. Parking brake is cable actuated, operating conventional type brake shoes against a drum machined in rear disc brake rotor casting.

ADJUSTMENT

DISC PADS

Front and rear disc brake assemblies are self-adjusting, therefore, no adjustment in service is required.

PARKING BRAKE

Release parking brake lever, raise and support vehicle, and remove rear wheels. Insert a brake adjusting tool through .6" hole in rotor, turn adjuster until rotor can no longer be turned, then back off adjuster two or three teeth. Working inside driver compartment, tighten adjustment nuts on lever until parking brake holds vehicle securely before fifth ratchet stop is reached.

HYDRAULIC SYSTEM BLEEDING

NOTE — Manufacturer recommends replacing brake fluid in entire system once a year to avoid moisture build-up. Attach a pressure bleeder to master cylinder reservoir.

CAUTION — Do not exceed 29 psi. Raise and support vehicle and remove wheels. Attach a bleeder hose to bleeder screw, and immerse opposite end of hose into a container partially filled with brake fluid. Open bleeder screw, allow all air to escape, then close bleeder screw. Continue operation until all air has been expelled from system. **NOTE** — On front wheel four piston calipers, bleed lower inboard screw before bleeding lower outboard screw.

REMOVAL & INSTALLATION

DISC PADS

Removal — Raise and support vehicle and remove wheels. Drive out retaining pins toward inside of vehicle and remove cross spring. Using an extractor tool, remove disc pads from caliper assembly.

Installation — 1) **NOTE** — Replacement of disc pads should be done in complete sets only. Using a cylinder brush, clean guide surface and support surface in caliper. Siphon sufficient fluid from master cylinder reservoir to prevent overflowing, then press pistons to bottom of bores.

2) On rear two piston calipers, ensure machined position of piston face makes a 20° angle to lower caliper wall. Install disc pads, cross spring, and retaining pins. After installation, depress brake pedal several times to position pads against rotor.

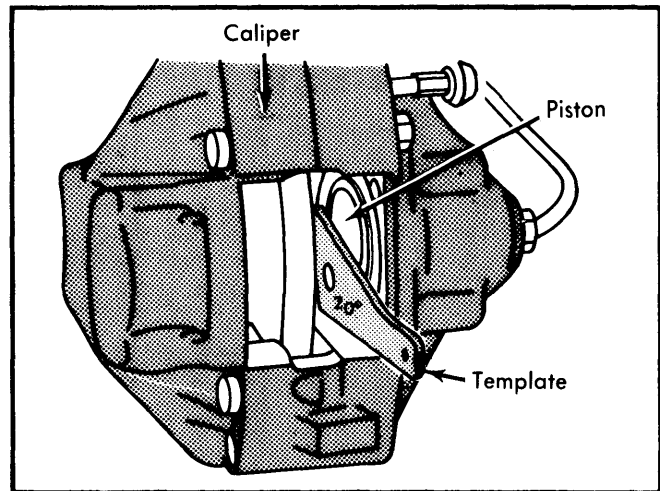

Fig. 1 Piston Alignment — Calipers With Dual Pistons

CALIPER ASSEMBLY

Removal — Remove master cylinder reservoir cap and plug fluid outlet lines. Raise and support vehicle and remove tire and wheel assembly. Disconnect hydraulic line(s), remove caliper mounting bolts, and separate caliper from backing plate.

Installation — Reverse removal procedure and bleed hydraulic system.

ROTOR

Removal & Installation (Front) — With caliper assembly removed, remove hub grease cap, cotter pin, and nut. Remove hub and rotor assembly. Remove Allen head bolts retaining rotor to hub and remove rotor. To install, reverse removal procedure, tighten all bolts and fittings evenly, and bleed hydraulic system if necessary. Adjust front wheel bearing. See *Wheel Bearing Adjustment* in **WHEEL ALIGNMENT** Section.

Removal & Installation (Rear) — Remove rear wheel and caliper assembly, then pull rotor out from axle shaft flange. To install, reverse removal procedure and note the following: Properly align holes in rotor with axle shaft flange. Tighten all bolts and fittings evenly and bleed hydraulic system, if necessary.

PARKING BRAKE SHOES

Removal — With rear caliper and rotor removed, disconnect lower return spring using brake spring pliers. Turn retaining springs 90° using removal tool, then set spring aside. Pull brake shoes apart at bottom and lift upward.

Installation — Reverse removal procedure and adjust parking brake shoes and cables.

MASTER CYLINDER

Removal — Remove master cylinder reservoir cap and plug fluid outlet lines. Remove hose fittings from master cylinder and raise above reservoir fluid level. Mark hydraulic lines for reassembly reference and disconnect from master cylinder. Remove nuts attaching cylinder to power unit, and separate master cylinder from power brake unit.

Brakes

BMW 6 CYLINDER (Cont.)

Installation — Reverse removal procedure and note the following: Make sure rubber "O" ring seal between master cylinder and power unit is not damaged. Check clearance between power unit thrust rod and master cylinder piston with Plastigage and, if necessary, set to .020" by inserting a shim behind plunger head. Bleed hydraulic system and check for fluid leaks.

POWER BRAKE UNIT

Removal, 3.0 — 1) Remove air cleaner and battery, disconnect oil reservoir from power steering (if equipped) and move to one side. Block brake fluid reservoir outlets and remove lines from master cylinder.

2) Remove lower left instrument panel housing and secure to one side. Remove brake pedal clevis pin, and disconnect vacuum hose from intake manifold. Remove hydraulic lines from master cylinder marking positions for reassembly reference. Remove nuts retaining power unit to support and remove power unit.

Installation — To install, reverse removal procedure, bleed hydraulic system and check following adjustments: Adjust push rod (A) length to 14.49-14.53" (368-369 mm). Adjust pedal height (B) to 9.65" (245 mm). Adjust exposed depth of brake light switch plunger (C) to .240-.280" (6-7 mm). See Fig. 3.

Removal, 530i — Siphon some brake fluid from master cylinder. Unbolt coolant reservoir and position out of way. Disconnect brake pedal push rod shaft. Disconnect vacuum hose at power brake unit (servo). Separate each brake line from master cylinder and mark each for reinstallation reference. Unbolt power brake unit holder and remove.

Installation — To install, reverse removal procedure, bleed hydraulic system, and check following adjustments: Adjust pedal height (B) to 9.05" (230 mm) for manual transmission models and 8.66" (220 mm) for automatic transmission models. Adjust exposed depth of brake light switch plunger (C) to .200" (5 mm). See Fig. 3.

Check Valve Replacement — Check valve is located in power unit vacuum line at intake manifold. To remove, loosen hose clamps, remove vacuum hoses, and remove valve. To install, reverse removal procedure, making sure arrow or black portion of valve faces intake manifold.

Filter Replacement — With power brake unit removed from vehicle, pull back rubber dust boot and remove retaining ring. Remove silencer and filter. To install, reverse removal procedure.

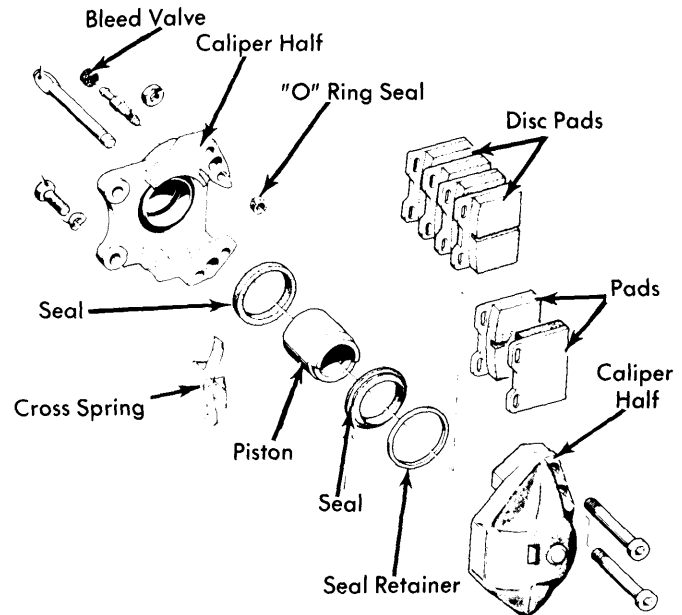

Fig. 2 Disassembled View of Dual Piston Rear Disc Brake

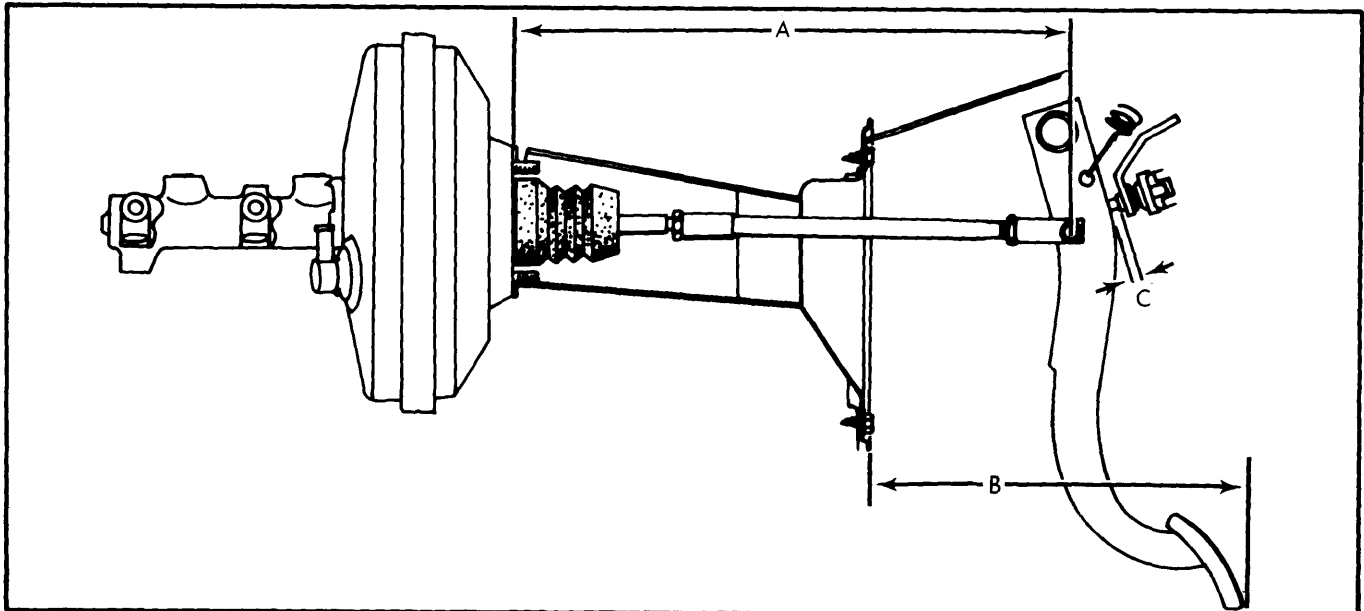

Fig. 3 Power Brake Unit Push Rod Measurement Locations

BMW 6 CYLINDER (Cont.)

OVERHAUL

BRAKE CALIPER

Disassembly — With caliper removed from vehicle and disc pads removed from caliper, remove clamping rings and rubber protecting caps. Hold one piston in place using a suitable clamp, insert a piece of wood in caliper cavity, then apply compressed air to fluid inlet and remove opposite piston. Remove sealing ring using a suitable plastic tool. Remove remaining piston(s) and seal(s) in same manner. **NOTE** — *DO NOT separate caliper halves unless a leak is detected.* To disassemble, remove expansion bolts, separate caliper halves, and remove sealing rings.

Cleaning & Inspection — Clean all parts in alcohol and check for wear or damage; replace parts as necessary.

Reassembly — Reassemble caliper (if separated) using new seals and expansion bolts. Tighten expansion bolts from inside out. Coat pistons and caliper bores with ATE brake cylinder paste (or equivalent), install sealing rings, then install pistons into bores. Make sure pistons are not tilted when inserting. On two piston calipers, make sure machined surface of piston face makes a 20° angle to lower caliper wall. Install rubber protecting caps and clamp rings.

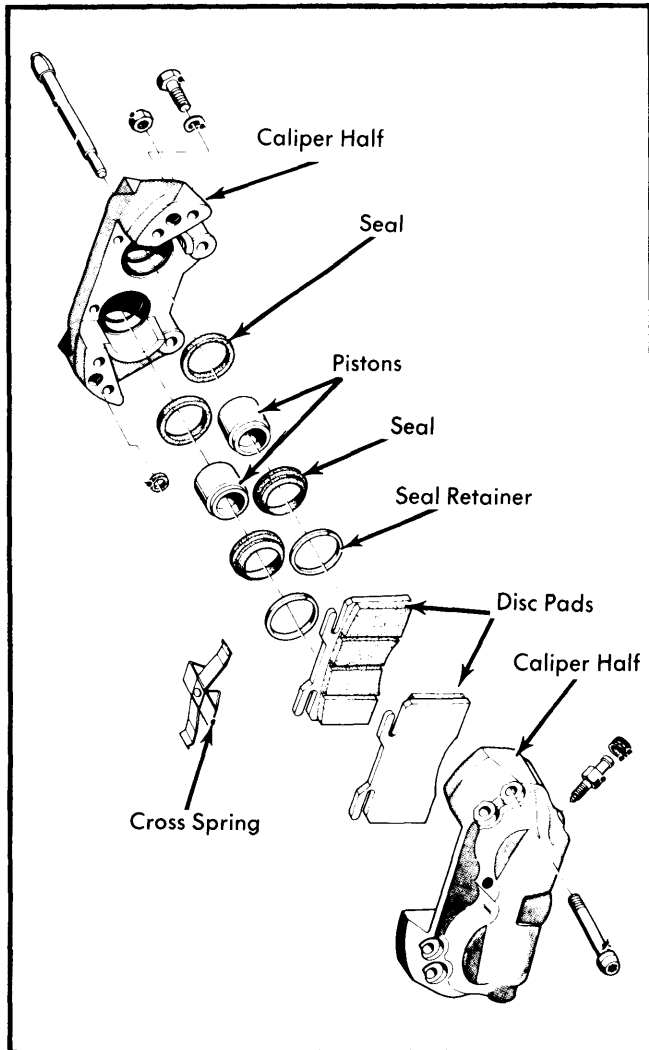

Fig. 4 Four Piston Front Disc Brake Caliper Assembly

MASTER CYLINDER

Disassembly — Push in on primary piston and remove secondary piston stop screw. Remove snap ring from end of cylinder and remove primary and secondary piston assemblies and return spring. Disassemble piston assemblies noting number and position of parts used.

Cleaning & Inspection — Clean all parts in alcohol and inspect for wear or damage. **NOTE** — *Cylinders with surface defects in bores must be replaced; do not overhaul.*

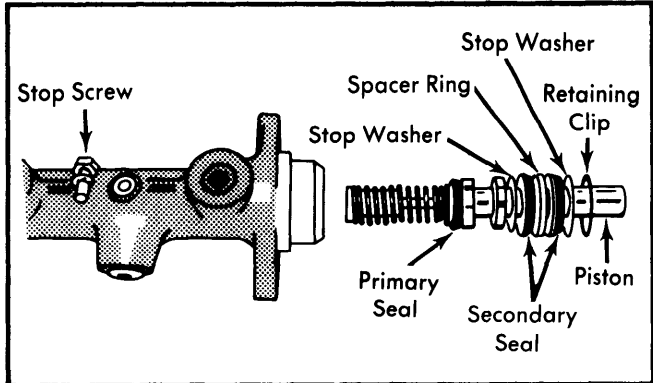

Fig. 5 Master Cylinder Primary Piston Assembly

Reassembly — Reassemble piston assemblies using thin coating of ATE brake paste. Install piston assemblies into cylinder bore using a suitable guide sleeve (BMW 34 3 000) to prevent damaging seals. Install secondary piston stop screw, making sure that piston is pushed fully forward before screw is installed and tightened. Install retaining ring in end of master cylinder bore.

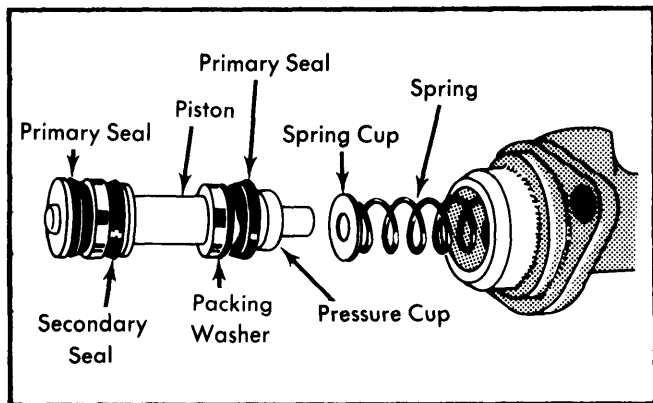

Fig. 6 Master Cylinder Secondary (Front) Piston Assembly

TIGHTENING SPECIFICATIONS

Application	Ft. Lbs. (mkg)
Caliper Mounting Bolts	
Front	58-69 (8-9.5)
Rear	43-48 (6-6.7)
Rotor-to-Wheel Hub	43-48 (6-6.7)
Brake Line-to-Caliper	9-12 (1.3-1.6)
Caliper Expansion Bolts	
Front.....	33-41 (4.6-5.7)
Rear	16 (2.2)

Brakes

BMW 6 CYLINDER (Cont.)

DISC BRAKE ROTOR SPECIFICATIONS						
Application	Disc Diameter In. (mm)	Lateral Runout In. (mm)	Parallelism In. (mm)	Original Thickness In. (mm)	Minimum Refinish Thickness In. (mm)	Discard Thickness In. (mm)
3.0						
Front	10.708 ^① (272)	.008 ^② (.2)	.0008 (.02)	.866 (22)827 (2)
Rear	10.708 ^① (272)	.008 ^② (.2)	.0008 (.02)	.748 (19)709 (18)
530i						
Front	10.708 ^① (272)	.008 ^② (.2)	.0008 (.02)	.499 (12.7)460 (11.7)
Rear	10.708 ^① (272)	.008 ^② (.2)	.0008 (.02)	.374 (9.5)334 (8.5)

① - ±.008" (.2 mm).

② - Installed on vehicle.