

OPEL RACK & PINION

All Models

DESCRIPTION

Steering gear is a rack and pinion type. Gear housing is held to crossmember by rubber bushing and clamps. Pinion shaft is seated in upper portion of gear housing and is supported by a needle bearing in upper housing and a bushing in lower housing. Pinion is not adjustable. Rack and pinion are held in mesh by a thrust spring and shell.

ADJUSTMENT

STEERING GEAR BACKLASH

Set gear to high point by positioning front wheels straight-ahead. Flexible coupling bolt holes will be positioned parallel to the rack. Thread adjusting screw into gear housing until a resistance is felt. Back off screw $\frac{1}{8}$ - $\frac{1}{4}$ turn. Tighten lock nut. Fill area under pinion shaft rubber boot with gear lubricant and slide boot into position.

REMOVAL & INSTALLATION

STEERING GEAR

Removal — Remove splash shield from lower deflector panel and both side members. Remove clamp bolt securing flexible coupling to steering shaft. Detach tie rods from steering arms. Unbolt, then remove gear assembly and tie rods from vehicle.

NOTE — If fasteners or attaching parts are replaced, it is imperative that ones of equivalent grade are used.

Installation — To install, reverse removal procedure, noting the following: First set gear and steering wheel in center positions, and ensure slot of lower steering mast matches bolt hole of flexible coupling pinion flange.

OVERHAUL

STEERING GEAR

Disassembly — 1) Clamp gear assembly in padded vise. Disconnect left and right tie rod ends from axial joints (at lock nuts). **NOTE** — Ball joint of tie rod end is maintenance-free; if defective, it must be replaced as an assembly. Unclamp and remove both rubber bellows.

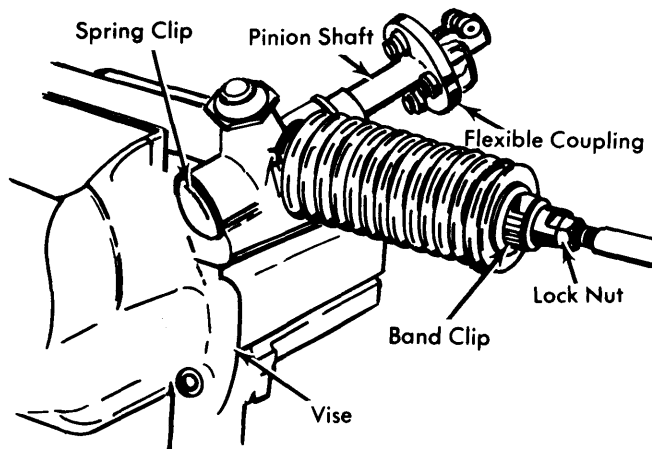

Fig. 1 Removing Tie Rod Ends from Axial Joint

2) Disconnect ball stud of axial joint from rack (lock plate and stop plate). **CAUTION** — Securely hold rack while detaching axial joint, or rack teeth will be damaged. Axial joint is maintenance-free and must be replaced as assembly, if defective.

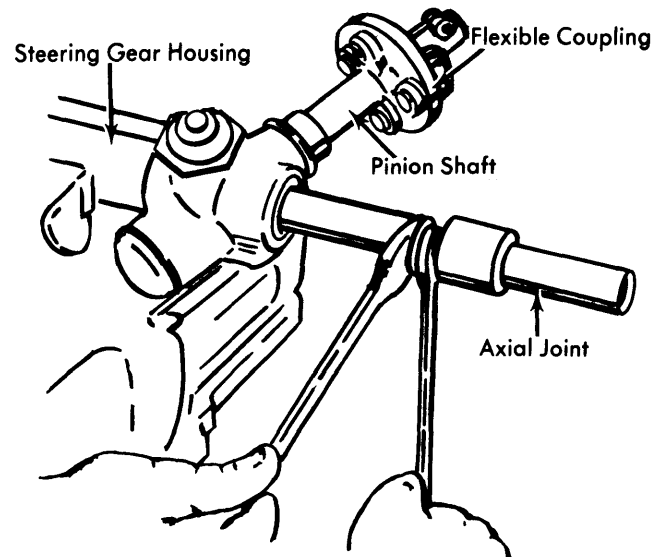

Fig. 2 Separating Axial Joint

3) Loosen adjusting screw lock nut, remove adjusting screw; withdraw thrust spring and bearing. Remove sheet metal cap from gear housing and remove hex nut from pinion. Do not turn pinion in end position. Pull pinion and rack from housing.

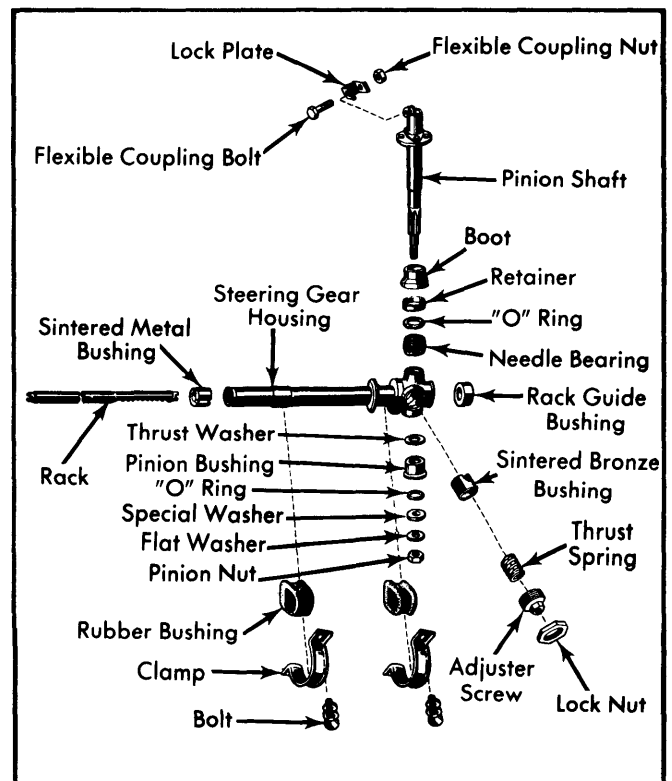

Fig. 3 Exploded View of Opel Steering Gear Assembly

Steering Gears & Linkage

OPEL RACK & PINION (Cont.)

Assembly — 1) With gear housing in padded vise, place new "O" rings onto retainer and pinion shaft bushing. Install thrust washer onto pinion bushing. Coat all moving parts with gear oil. Fill long end of housing with approximately 1 ¼ oz. of gear oil.

2) Insert long, smooth end of rack into short end of housing until rack ends protrude evenly from housing. Ensure that three air channels of sintered bushing are not blocked by lubricant.

3) Reassemble pinion shaft into gear assembly so that spline in pinion shaft meshes with twelfth tooth of rack. Use special pinion mounting sleeve (J-21712) during pinion installation to avoid damage to "O" ring in pinion bushing. Ensure pinion is positioned such that bolt hole in flexible coupling is on top and parallel to rack.

4) Reassemble special washer, flat washer, and new pinion nut onto pinion shaft. **CAUTION** — Pinion nut must be tightened to 20 Ft. Lbs. (2.7 mkg). Do not exceed this specification or gear jam may result.

5) Place sintered bronze bushing into gear housing and fill adjusting hole with gear lubricant. Reassemble thrust spring, adjuster screw, and lock nut on gear assembly.

6) Screw ball stud of axial joint together with stop plate onto both ends of rack (hold rack from turning). Slide rubber bellows into position and clamp such that clamp screws are facing same direction as adjuster screw.

TIGHTENING SPECIFICATIONS

Application	Ft. Lbs. (mkg)
Flexible Coupling Clamp.....	19 (2.63)
Axial Joint Ball Stud-to-Rack.....	65 (8.99)
Gear Housing-to-Crossmember.....	29 (4.01)
Adjusting Screw Lock Nut.....	49 (6.77)
Pinion Lock Nut.....	20 (2.77)
Tie Rod-to-Steering Arm.....	29 (4.01)