

## AUDI FOX RACK & PINION

Fox

### ADJUSTMENT

#### STEERING GEAR FREE PLAY

**With Adjusting Screw** — On models which have an adjusting screw in the gear cover plate, free play adjustment may be made using this screw. Loosen lock nut and tighten screw until it touches thrust washer. Tighten lock nut.

**NOTE** — Should this adjustment not eliminate free play, make further adjustment as described in the following paragraph.

**Without Adjusting Screw** — Free play adjustment for vehicles without an adjusting screw in the gear cover plate may be made as follows: Remove shim pack from beneath cover plate. Measure total thickness of shim pack, then reduce shim pack thickness by .002" (.05 mm) by removing one shim. Replace remaining shim pack to check steering for proper movement by turning steering from lock to lock. Smooth movement without free play should be felt. Repeat adjustment if necessary (remove an additional shim).

**CAUTION** — Do not turn gear hard against either lock when vehicle is raised off ground or damage may result.

### REMOVAL & INSTALLATION

#### STEERING GEAR

**Removal** — After removing both tie rod mounting bolts from rack, pry tie rods off steering gear. Remove lower instrument panel trim. Loosen bottom steering column mounting bolt and pry off clip. Drive bottom of column off gear, using a brass mandrel. Remove gear mounting bolts from body. Turn front wheels to right lock and remove steering gear through opening in right wheel well.

**Installation** — Before installing steering gear in vehicle, install the slider (in which both sealing sleeves are welded into the cup — see illustration). Install steering gear. To facilitate installation of tie rods, remove one bolt from the slider, install tie rod, and reinstall bolt. Repeat procedure for other tie rod. After tightening bolts, secure with lock plate.

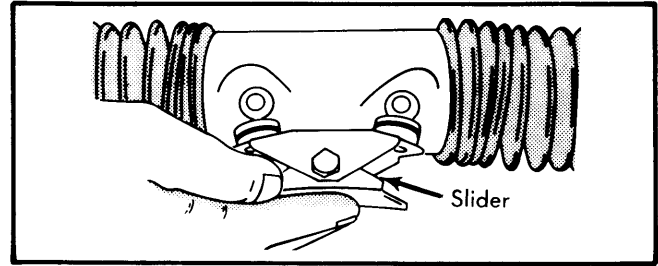

Fig. 2 Proper Position for Reinstallation of Slider

#### STEERING DAMPER

**NOTE** — Replacement of steering damper is the only service procedure recommended. Do not attempt repairs on this unit.

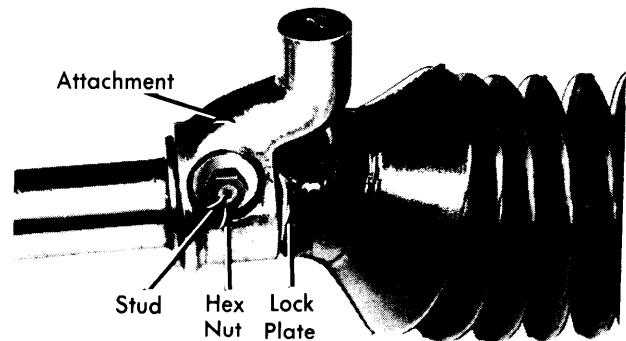

Fig. 3 Assembled View of Damper Attachment

**Installation** — When reinstalling, first place boot over track rod and attachment. Slide attachment onto track rod, aligning hole for stud with groove in track rod. Insert stud, attach and tighten hex nut. When damper is installed, distance from center of outer rack mounting bracket to center of inner damper mounting bracket should be 11.3" (287 mm).

### OVERHAUL

**NOTE** — Manufacturer does not recommend overhaul of this rack and pinion steering unit. If unit is determined defective, replace as assembly.

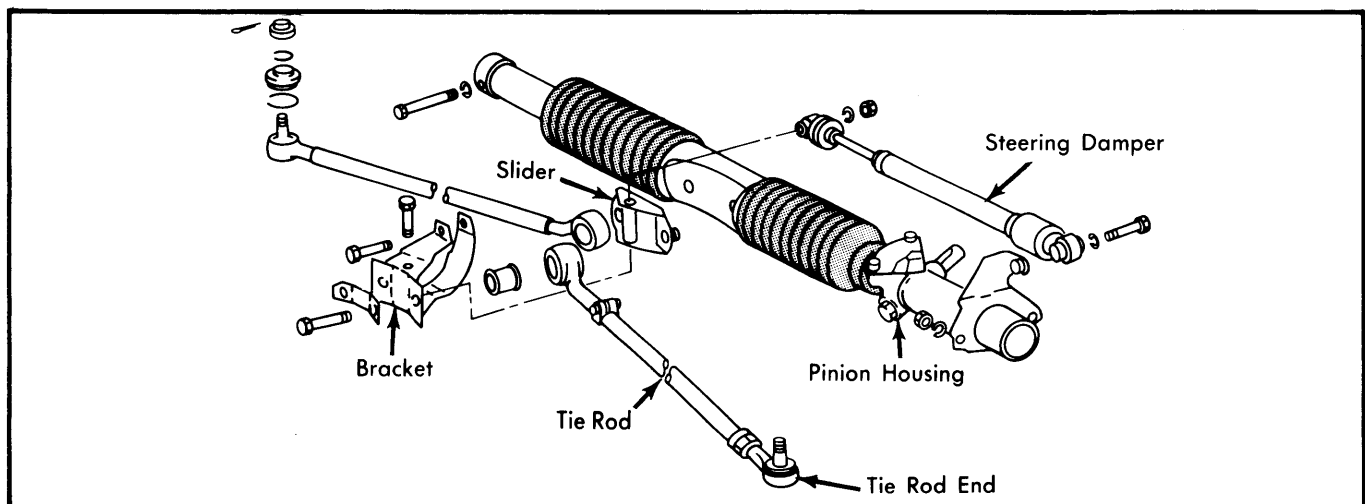

Fig. 5 Audi Fox Rack and Pinion Assembly