

OPEL

All Models

DESCRIPTION

Steering column is a ball type energy absorbing unit with a plastic pin type shaft. Column and shaft will collapse during a front end collision by the shearing of the injected plastic pins. The column is attached at the instrument panel and by a flexible joint at the steering gear.

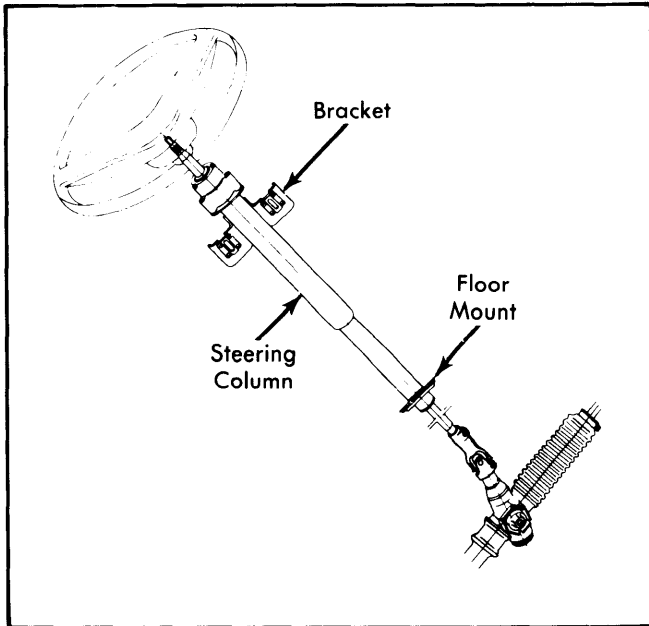

Fig. 1 Steering Column Assembly

REMOVAL & INSTALLATION

Removal — Disconnect battery negative cable. Remove flexible joint bolt and two lower column guide bolts. Remove two column-to-instrument panel nuts and disconnect electrical connections. Withdraw column and shaft assembly.

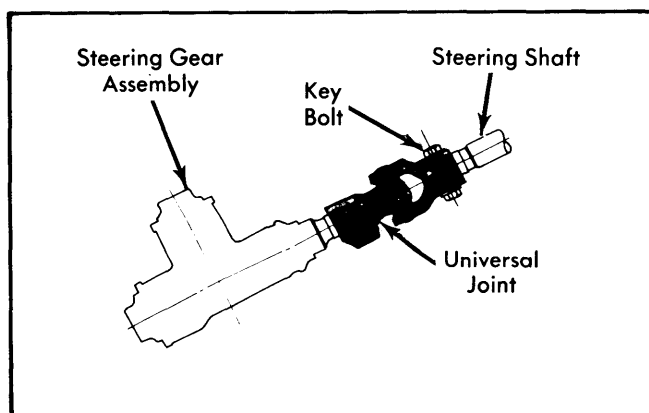

Fig. 2 Flexible Joint

Installation — Install steering column assembly and loosely install two upper column-to-instrument panel nuts. Insert steering shaft into flexible coupling and torque key bolt nut to specification. Slide lower column guide down and bolt to floor pan. Position front wheels straight ahead and install steering wheel, making sure the turn signal cancelling pin is in the hole in the back of steering wheel. Install steering wheel washer and nut, then torque nut to specification.

OVERHAUL

Disassembly — 1) Remove two horn button retaining screws, disconnect horn contact, then remove steering wheel nut and washer. Use suitable steering wheel puller and remove steering wheel. Remove screws from upper and lower column covers and hazard warning switch and remove switch unit.

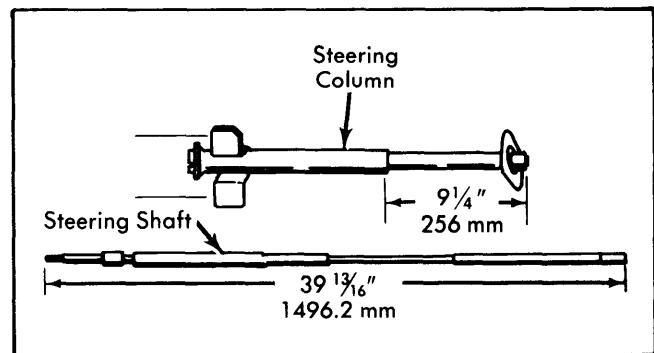

Fig. 3 Column and Shaft Measurements

2) Remove two retaining screws and take out windshield washer and wiper switch. Remove snap ring, washer and three attaching bolts on column flange, then remove lock cylinder housing, lower washer and shaft. Pry out lower column rubber bushing with a screwdriver.

Inspection — Check measurement of lower column and steering column shaft for correct measurement (See Fig. 3). If not to specifications replace component.

Assembly — 1) Assemble flat washer, lock cylinder housing, washer and snap ring on the shaft. Then install shaft assembly in the steering column and install lock cylinder retaining screws.

2) Install windshield wiper/washer switch and combination turn signal, headlight dimmer, and hazard warning flasher switch. Install upper and lower column covers and hazard warning button.

TIGHTENING SPECIFICATIONS

Application	Ft. Lbs. (mkg)
Key Bolt	18 (2.49)
Steering Wheel Nut	22 (3.04)