

ARROW & COLT

Arrow
Colt

DESCRIPTION

Collapsible steering system is comprised of a two-piece (upper and lower) column shaft, joined by a collapsible section. This section contracts axially under impact without affecting turning motion. Upper column cover incorporates slits, allowing it to collapse under impact.

REMOVAL & INSTALLATION

Removal – Remove air cleaner. Unbolt clamp retaining shaft to gear box. Remove horn pad, steering wheel nut and pull steering wheel. Unscrew tilt lock knob, detach column cover and remove combination switch assembly. Draw out each switch connector and detach switch. Remove floor dust cover. Loosen tilt bracket retaining bolt and withdraw steering column assembly.

Installation – 1) Be sure shaft can easily be turned within the column, insert column assembly, and position against instrument panel. Connect shaft to steering gear housing mainshaft with clamp bolt head upward. Position tilt bracket such that a measurement of 3.70-3.74" (84-95 mm) exists from upper end of steering shaft to upper end of column tube. Placement of shims between rear edge of bracket and instrument panel will assist in giving correct measurement.

2) Position front wheels in straight-ahead position, install steering wheel, and tighten retaining nut to specification. Be sure maximum free play at circumference of steering wheel does not exceed .04" (1.02 mm).

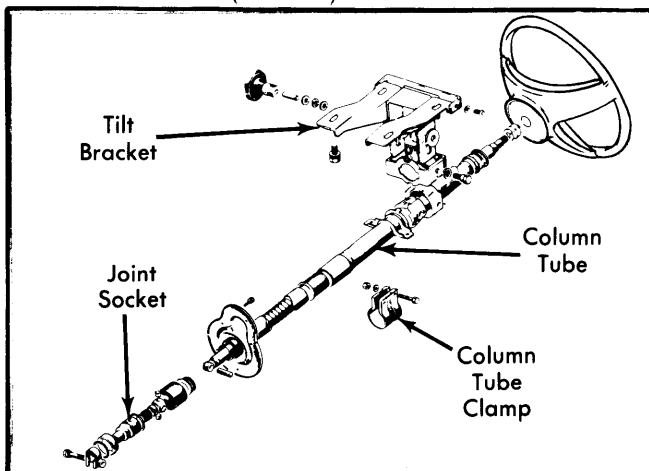

Fig. 1 Exploded View of Steering Column Assembly

OVERHAUL

Disassembly – 1) Pull lower shaft bearing out of column and remove shaft. Remove cover from the steering shaft joint socket, remove the stopper, and withdraw the retainer. With steering shaft upright, pull out joint retaining pin, using a magnet. Remove joint socket.

2) Loosen column tube clamp, draw out column tube, and remove the column bushing. When removing the tilt bracket, cut a slot in head of retaining studs, then unscrew studs, and remove steering lock. Lightly tap the tilt bracket with a wooden hammer to drive the bracket assembly from the upper end of column tube.

Assembly – 1) Place joint socket (bearing) on shaft lower end with flanged surface upward and lubricate socket, dust cover and ball seat. Insert pin in same manner as removal. Set gear mainshaft in straight-ahead position, attach and tighten socket clamp. Install both column tube bushings. Position and torque bushing stoppers against column ends.

2) Install tilt bracket on column, with spacers between column and tilt bracket, then insert bolt. Install a lock washer between two plain washers on bolt and tighten tilt knob. Install steering wheel lock. Check lock function with ignition key then tighten retaining bolt until head shears off.

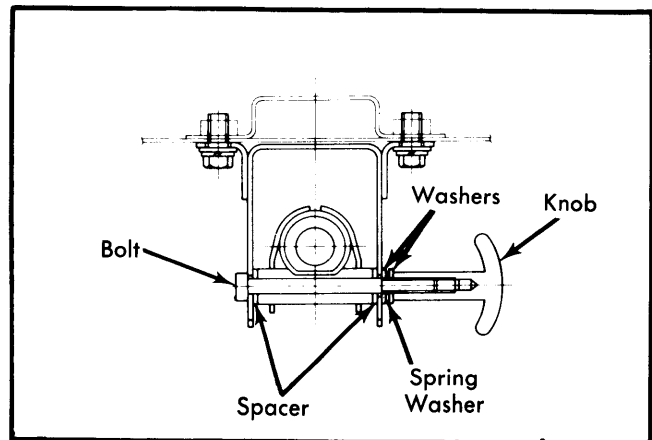

Fig. 2 Tilt Bracket Installation

NOTE – During any service operations of collapsible columns or components avoid jarring or leaning on any portion of column.

TIGHTENING SPECIFICATIONS

Application	Ft. Lbs. (mkg)
Steering Wheel Nut	25-33 (3.5-4.5)
Steering Wheel Lock	
Shear-Head Bolts	⓪5-9 (.7-1.2)
Shaft Clamp Bolt	15-18 (2.0-2.5)

⓪ – Breaking torque.