

PORSCHE 911

911

DESCRIPTION

Independent torsion bar type rear suspension. Torsion bars are mounted inside rear crossmember tube and anchored in center by a splined hub. Outer end of torsion bars mount into splined hubs integral with spring plates which connect at ends to control arms. Control arms pivot in mounts integral with body and also serve as rear wheel bearing carriers. Hydraulic shock absorbers mount between control arms and inner fender panel. A stabilizer bar is installed on some models.

ADJUSTMENT

WHEEL ALIGNMENT SPECIFICATIONS & PROCEDURES

See *Wheel Alignment Specifications & Procedures* in **WHEEL ALIGNMENT** Section.

REMOVAL & INSTALLATION

SHOCK ABSORBERS

Removal — 1) Raise vehicle and place safety stands in a position so weight of vehicle is still on rear wheels. Remove rubber cap from upper mount (accessible from inside engine compartment) and remove nut from shock absorber stem.

2) Remove bolt securing shock absorber to control arm and remove shock absorber. Remove rod cover and rubber buffer from shock absorber.

Installation — Inspect rubber buffer for wear or cracking and replace if necessary. Make sure that stop disc grooves face bottom of shock absorber when assembling. Install rubber buffer and cover and reverse removal procedure to install remaining components. Tighten upper and lower mounts.

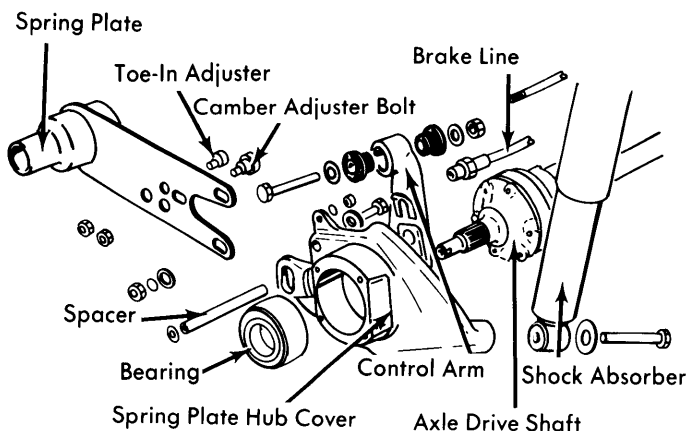

Fig. 1 911 Rear Suspension Assembly Expanded View

CONTROL ARM

Removal — 1) Raise vehicle and place safety stands under body. Remove rear wheels. Detach brake system components from rear wheel hub. See *Porsche* in **BRAKE** Section. Remove axle hub cotter pin and nut. Remove Allen head bolts from axle shaft flanges and remove axle shaft.

2) Using a suitable driver, remove rear wheel hub from control arm. Remove cotter pin and nut from parking brake cable and pull cable out toward center of vehicle. Remove bolts securing parking brake assembly to control arm and remove assembly.

3) Raise torsion bar spring plate to take tension from shock absorber with a suitable tool. Remove lower shock absorber mount. Remove bolts securing spring plate to control arm. Disconnect brake hose from bracket on control arm. Remove nut from control arm pivot bolt and drive bolt out with a punch. Remove control arm from vehicle.

Installation — Reverse removal procedure and note the following: Use new self-locking nuts and tighten all bolts and nuts. Check wheel alignment and bleed brake system.

TORSION BAR & SPRING PLATE

Removal — 1) Raise vehicle and place safety stands under body. Remove wheel and tire. Raise torsion bar spring plate using suitable equipment. Remove lower shock absorber mounting bolt. Remove bolts securing spring plate to control arm. Pull back on control arm to separate from spring plate.

2) Remove torsion bar hub cover bolts and remove cover by prying off with a screwdriver. Remove torsion bar tensioner tool. Remove plug from body, remove spring plate and withdraw torsion bar. If torsion bar is broken, opposite side torsion bar will have to be removed in order to drive out broken piece.

Installation — 1) Inspect all components for wear or damage. Coat torsion bar with lithium grease before installing. Torsion bars are marked left and right; install accordingly. Coat rubber components with glycerin paste. Install torsion bar and spring plate in correct position. See *Porsche* in **WHEEL ALIGNMENT** Section for proper torsion bar setting procedure.

2) Install hub cover and start three bolts that are accessible. Raise spring plate until remaining bolt can be installed. Reverse removal procedure for remaining components. Check rear wheel alignment.

TIGHTENING SPECIFICATIONS

Application	Ft. Lbs. (mkg)
Control Arm Pivot Bolt	87 (12.0)
Spring Plate-to-Control Arm Bolts.....	65 (9.0)
Camber Adjusting Bolt.....	43 (6.0)
Tracking Adjusting Bolt.....	36 (5.0)
Lower Shock Absorber Mount.....	54 (7.5)
Hub Nut	235 (32.5)
Axle Shaft Allen Head Bolts	
M10-8G	34 (4.7)
M8-12K	31 (4.3)
M10x55-12K	60 (8.3)
Torsion Bar Hub Cover Bolts	34 (4.7)