

SUBARU

1400

REMOVAL & INSTALLATION

DESCRIPTION

Suspension is strut type, utilizing a hydraulic shock absorber/coil spring assembly forming a strut. Strut is secured at top to body and at bottom to steering knuckle. Steering knuckle pivots on ball joint attached to lower control arm. Lower control arms are attached to front crossmember. Radius rods are welded to lower control arms and attached to rear crossmember with rubber bushings, washers, and nuts. A stabilizer bar is also used and attached to rear crossmember and to radius rods with clamps and rubber bushings.

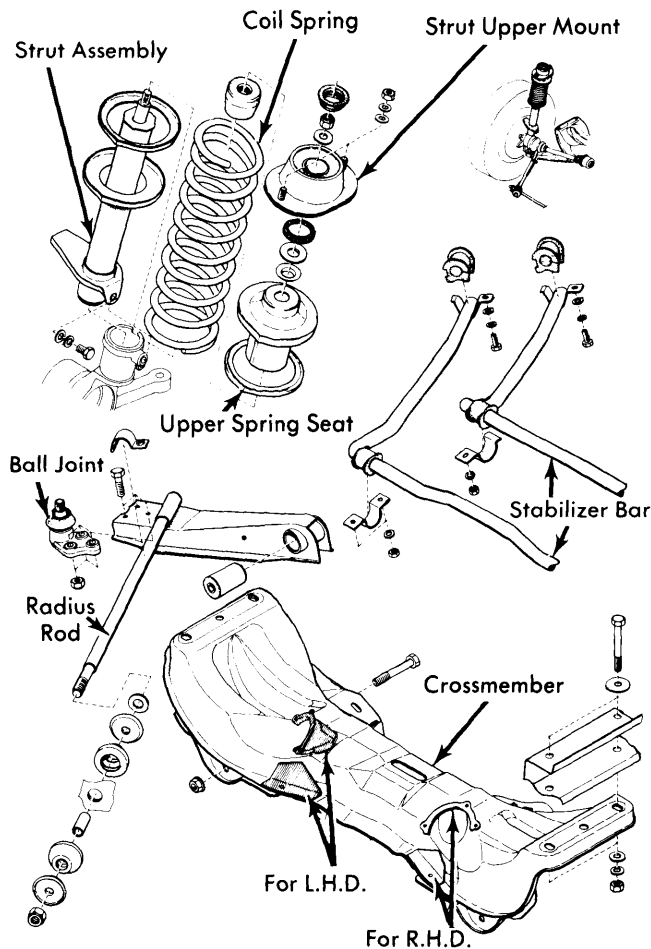

Fig. 1 Exploded View of Front Suspension Assembly

ADJUSTMENT

WHEEL ALIGNMENT SPECIFICATIONS & PROCEDURES

See appropriate story in WHEEL ALIGNMENT Section.

WHEEL BEARING ADJUSTMENT

See appropriate story in WHEEL BEARING ADJUSTMENT Section.

BALL JOINT CHECKING

See appropriate story in BALL JOINT Section.

FRONT SUSPENSION

Removal – 1) Disconnect battery ground cable. Disconnect parking brake cable bracket on control arm. Remove axle nut and pull brake drum off using a suitable puller (925200000). Disconnect flex brake lines from steel brake lines. Separate backing plate assembly from steering knuckle. On vehicles equipped with disc brakes, disconnect parking brake cable from caliper. Remove outer cable clip and remove cable bracket from housing mount.

2) Drive pins out of "U" joints at transaxle. Remove control arm pivot bolt. Disconnect stabilizer bar-to-radius rod clamps, then remove radius rod-to-rear crossmember attaching nut, washer, and rubber bushing. Remove tie rod stud nut and separate tie rod from steering knuckle using a puller. Remove strut assembly upper mounting nuts, pull "U" joint from transaxle and remove complete suspension assembly. Follow same procedure for removal of opposite side suspension assembly.

Installation – To install suspension assembly, reverse removal procedure. Tighten control arm-to-crossmember attaching bolt with weight off of front wheels. Replace all self-locking nuts with new ones during installation. Check wheel alignment. Bleed brake system.

STRUT ASSEMBLY

Removal – Raise front of vehicle and support with safety stands. Remove wheels. Remove bolt securing strut assembly to steering knuckle. Disconnect tie-rod from steering knuckle. Pull down on control arm, separating strut assembly from steering knuckle. Remove upper strut assembly mounting nuts and remove strut assembly.

Installation – To install strut assembly, reverse removal procedure. Tighten all bolts and nuts to specifications and check wheel alignment.

STRUT ASSEMBLY OVERHAUL

Disassembly – Install strut assembly in a suitable holding fixture and spring compressor (925160000). Compress coil spring with compressor until upper spring seat is clear of spring. Hold upper mount by attaching a suitable holding tool (925170000) to bolts and remove nut from center shaft. Pull strut mount from rod, remove thrust washer with oil seal and thrust bearing. Pull off upper spring retainer. Loosen spring compressor and remove spring when completely released.

Inspection – Push and pull center shaft in and out of strut assembly. Pressure should be equal during both strokes. Replace strut assembly if defective. Check outer layer of thrust washer for cracks or wear. Check sliding surface of thrust bearing for wear or cracking. Inspect sealing lip of oil seal for damage.

Assembly – To assemble strut, reverse disassembly procedure. Apply grease to sealing lip of seal. Position thrust washer so that machined surface is facing coil spring. Tighten upper strut mount nut to specification.

SUBARU (Cont.)

STABILIZER BAR

Removal — Raise front of vehicle, and support with safety stands. Remove clamps securing stabilizer bar to radius rod. Remove clamps attaching stabilizer bar to rear crossmember.

Installation — Check all bushings for wear or damage and replace as necessary. Check stabilizer bar for possible cracking. To install, reverse removal procedure.

LOWER CONTROL ARM

Removal — Raise front of vehicle, support with safety stands, and remove wheel and tire. Disconnect brake cable bracket from control arm. Disconnect stabilizer bar from radius rod. Disconnect radius rod from rear crossmember. Remove control

arm-to-front crossmember attaching bolt. Remove ball joint-to-steering knuckle attaching nut and separate from knuckle. Remove control arm from vehicle.

Installation — Check ball joint for wear or damage. Check pivot bushing for wear or damage. To install control arm, reverse removal procedure.

TIGHTENING SPECIFICATIONS

Application	Ft. Lbs.(mkg)
Brake Backing Plate-to-Knuckle	21-32(3.0-3.5)
Tie Rod Strut Nut	18-21(2.5-3.0)
Strut-to-Steering Knuckle	21-28(3.0-4.0)
Strut Center Shaft Nut	43-54(6.0-7.5)