

## MAZDA RX3, RX4 &amp; 808

RX3  
RX4  
808

## DESCRIPTION

Independent strut type suspension with coil springs. Strut assemblies are mounted between lower control arms and upper fender panels. Strut assemblies consist of; a shock absorber built into strut outer tube, a coil spring mounted on outside of strut outer tube, and a steering knuckle integral with bottom of strut tube. Lower control arms pivot in mounts connected to crossmember and connect at outer ends to strut assemblies by means of ball joints. A stabilizer bar is mounted to front chassis members and connects at ends to lower control arms.

## ADJUSTMENT

## WHEEL ALIGNMENT SPECIFICATIONS &amp; PROCEDURES

See *Wheel Alignment Specifications & Procedures* in *WHEEL ALIGNMENT* Section.

## WHEEL BEARING ADJUSTMENT

See *Wheel Bearing Adjustment* in *WHEEL ALIGNMENT* Section.

## BALL JOINT CHECKING

See *Ball Joint Checking* in *WHEEL ALIGNMENT* Section.

## REMOVAL &amp; INSTALLATION

## STRUT ASSEMBLY

**Removal** — Raise vehicle and place safety stands under body. Remove wheel and tire. Remove nuts retaining strut assembly to fender panel, accessible from inside engine compartment. Remove fluid pipe to shock absorber and plug with cap to prevent dirt from entering system. Remove brake caliper and rotor (disc). **NOTE** — See appropriate article in *BRAKE SYSTEMS* Section for brake components removal. Remove two bolts from bottom of steering arm and remove strut assembly from vehicle.

**Installation** — To install, reverse removal procedure and tighten all nuts and bolts. Do not use more than two adjusting plates at one side when installing coil spring.

## CONTROL ARM

**Removal** — Raise vehicle and support with safety stands. Remove wheel and tire. Remove nut from tie-rod end stud and separate tie-rod from steering arm using a suitable puller (49 0118 850C). Remove bolts securing steering arm to strut tube. Remove nut securing stabilizer bar to control arm. Remove pivot bolt and separate control arm from crossmember. Pull out on strut assembly and remove control arm from vehicle. Remove cotter pin and nut from ball joint stud and separate from steering arm using a suitable puller (49 0727 575). If ball joint is damaged and requires removal, remove set ring and dust seal and press out of control arm using a suitable mandrel (49 0370 860).

**Installation** — Inspect control arm for distortion or wear. Thoroughly clean ball joint and mounting bore in control arm before assembling. Press ball joint into control arm using a suitable mandrel (49 037 860). Place steering arm on ball joint and tighten nut. Reverse removal procedure to install remaining components.

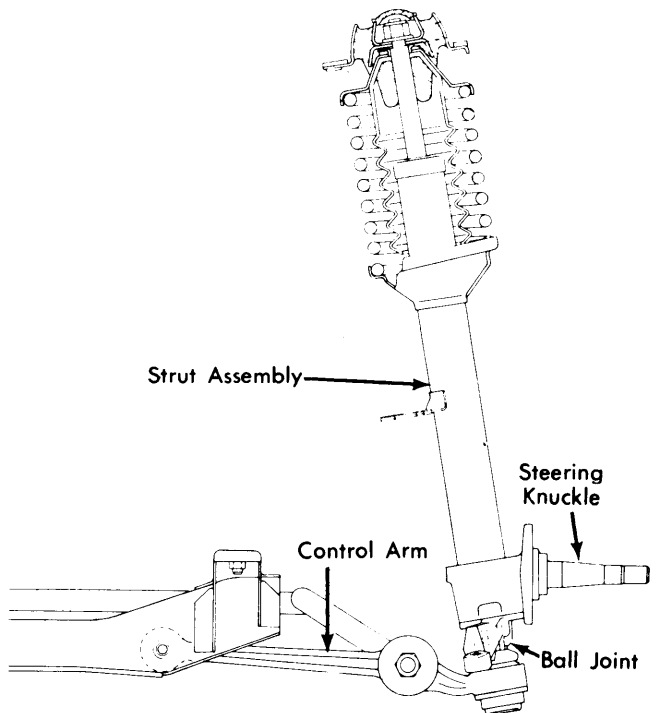
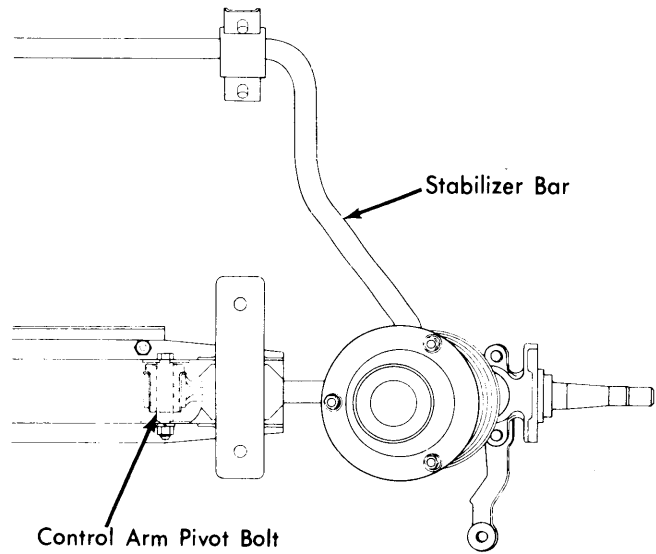

Fig. 1 Mazda Strut Front Suspension Assembly

## OVERHAUL

## STRUT ASSEMBLY

**Disassembly** — Clamp strut in a vise. Using a suitable spring compressor (49 0223 640A or 49 0223 641), compress coil spring. Remove nut from top of piston rod and remove upper support, spring seat, coil spring, dust seal, damper stopper, and dust cover. Using a suitable wrench (49 0259 700A), remove cap nut from top of strut tube. Remove "O" ring from inside strut tube, then pull out piston rod and pressure tube assembly. Slide piston rod guide, back-up ring, stopper and stopper guide from piston rod. Remove base valve assembly from bottom of pressure tube. Remove bolt and nut from valve

## MAZDA RX3, RX4 & 808 (Cont.)

assembly, and remove valve seat, relief valves, base valve casing and relief valves. Slide piston rod from pressure tube and secure upper portion of piston rod in a vise. Remove nut from piston rod, and slide off washer, centering valve, relief valves, piston check valves, check valve springs, and washer. Remove piston ring from piston.

**Inspection** — Check piston rod for wear, damage or scoring. Piston rod diameter should be more than .785" (19.94 mm). Use a dial indicator and suitable "V" blocks to ensure that piston rod run-out is not more than .006" (.15 mm). Inspect all valves and washers for wear or damage and replace as necessary. Check relief valve and check valve to ensure that flatness is less than .0008" (.02 mm). Check that inner diameter of pressure tube is 1.184" (30.07 mm) and check that tube run-out is less than .008" (.2 mm). Inspect cap nut for damaged threads and oil seal lip for wear or damage. Check that flatness for base valve is .0008" (.02 mm).

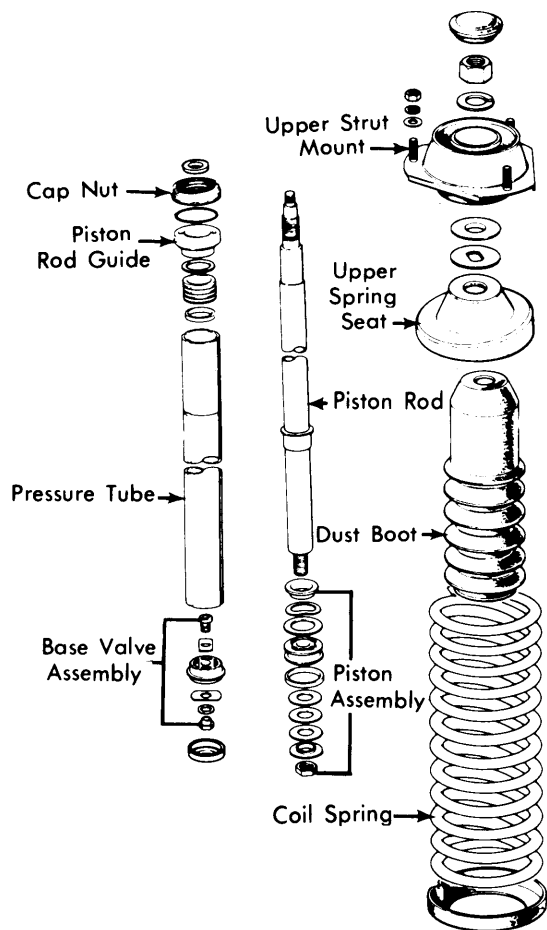

**Reassembly** — Position upper end of piston rod in a vise and install components in reverse of removal order. **NOTE** — Make sure piston is installed with constant orifice side up. Tighten nut to specification and stake around edge of nut to keep from working loose. Install four relief valves on bolt and install in base valve casing. Place five relief valves, washer, and nut, then tighten nut to specification. Stake in center of nut to prevent from working loose. Install piston rod into pressure tube from bottom and place stopper guide on piston rod with grooves toward base valve. Place stopper and back-up ring on piston rod. Insert base valve in bottom of pressure tube. Place one oil stop ring 5.12" (130 mm) from bottom and second oil stop ring 2.36" (60 mm) from bottom. Place pressure tube assembly in strut tube and fill with 9.1 ounces of shock absorber oil. Insert rod guide into strut tube along with "O" ring. Place oil seal guide (49 0370 590) on end of piston rod and install cap nut. Tighten temporarily making sure piston rod is pulled out to end of stroke. Push piston rod to bottom of stroke and tighten cap nut. Install coil spring and components in reverse of removal order and tighten nut.

Fig. 2 Exploded View of Typical Strut Assembly (RX3 & 808 Shown)

### TIGHTENING SPECIFICATIONS

Application	Ft. Lbs. (mkg)
Control Arm Pivot Bolt .....	29-40(4.0-5.5)
Ball Joint Stud Nut .....	43-51(5.9-7.1)
Piston Rod Nut .....	10(1.4)
Base Valve Nut .....	1(.14)
Cap Nut .....	36-43(5.0-5.9)