

VOLKSWAGEN

TYPE 1

Sedan
Super Beetle

TYPE 2

Transporter
Dasher
Rabbit
Scirocco

DESCRIPTION

Brake system is hydraulically actuated, using a tandem master cylinder and on some models, a power brake unit. Type 1 models are equipped with drum brakes on all four wheels. All other models are equipped with disc brakes on the front wheels and drum brakes on the rear wheels. All models with disc brakes are equipped with a pressure regulator in the rear brake circuit. The pressure regulator limits pressure to the rear brakes when foot brake is applied, preventing rear wheel lock-up. All models are equipped with a mechanical parking brake, operating on the rear brakes.

ADJUSTMENT

DISC BRAKES

Disc brakes are self-adjusting, therefore, no adjustment in service is required.

DRUM BRAKES

Type 2 (Rear Brakes) — Turn adjusting nut for both shoes three notches at a time, alternating from one nut to the other, until both shoes are rubbing on brake drum. Turn both nuts back alternately, until brake drum just rotates freely.

All Others — Turn adjuster until a slight drag is felt when rotating brake drum. Back off adjuster 3-4 notches, or until drum is just free to rotate.

PARKING BRAKE

Type 2 & Dasher — Raise and support vehicle and ensure rear brakes are properly adjusted. From under vehicle, loosen parking brake cable lock nut(s). Pull parking brake handle up six notches (Type 2), or two notches (Dasher) and tighten cable adjusting nut(s) until rear wheels can just be turned by hand. Tighten lock nut(s) and ensure rear wheels rotate freely with parking brake fully released.

All Others — Raise and support vehicle and ensure rear brakes are properly adjusted. Pull back rubber (plastic) boot at base of parking brake handle and loosen parking brake cable lock nuts. Pull handle up three notches and tighten each adjusting nut until rear wheels just lock. Tighten lock nuts and refit rubber (plastic) boot. Ensure rear wheels rotate freely with parking brake fully released.

HYDRAULIC SYSTEM BLEEDING

Pressure Bleeding — Attach bleeder connector cap to cylinder reservoir, and pressurize system to 43 psi. Attach one end of bleeder tube to cylinder bleeder screw, and submerge opposite end of tube in a jar half full of clean brake fluid. Open each bleeder screw in turn, and allow fluid to flow into container until fluid flows with no sign of air in fluid.

Manual Bleeding — Attach one end of bleeder tube to bleeder screw, and submerge opposite end in a jar half full of clean brake fluid. Pump brake pedal several times, and with pedal at bottom of stroke, open bleeder screw. Close bleeder screw, then release pressure on brake pedal. Repeat procedure until fluid flows from bleeder tube with no sign of air in fluid.

REMOVAL & INSTALLATION

FRONT DISC BRAKE PADS

Removal — Raise and support vehicle, and remove wheel. Using a punch, drive out pad retaining pins and remove spreader spring. Using a suitable extractor tool, remove pads from caliper. Inspect pads for wear or damage, and replace if lining thickness is less than .08".

Installation — Using a suitable piston retaining device, push pistons to bottom of cylinder bores. Remove piston retaining plate and clean all parts with denatured alcohol. Inspect all parts for damage. Check position of piston using a 20° gauge. Install piston retaining plate, insert disc pads and a NEW spreader spring. Using a hammer, install retaining pins into caliper. Depress brake pedal several times to seat pistons and disc pads.

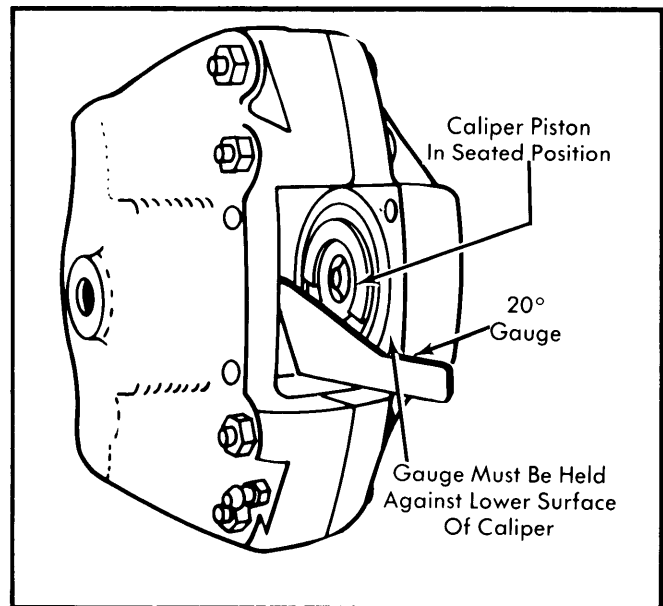

Fig. 1 Using a 20° Gauge to Properly Position Piston

DISC BRAKE CALIPER

Removal — Raise and support vehicle and remove wheel. Disconnect brake line from caliper and plug opening to prevent entry of dirt and foreign matter. Bend back locking tabs on mounting bolts at steering knuckle. Remove caliper mounting bolts and remove caliper assembly from vehicle.

Installation — To install, reverse removal procedure, using new lock plates and mounting bolts.

VOLKSWAGEN (Cont.)

DISC BRAKE ROTOR

Removal (Type 1) — Raise and support vehicle; remove wheel. Remove caliper assembly. Remove retainer from speedometer cable. Remove dust cap and clamp nut. Remove rotor and wheel hub assembly from vehicle complete with wheel bearings.

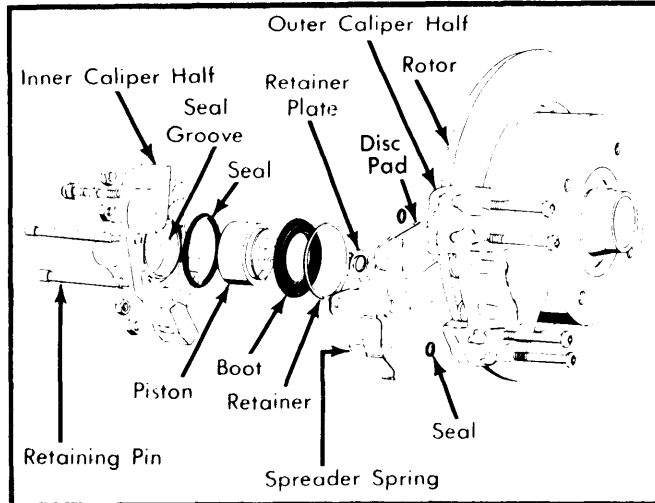

Fig. 2 Disc Brake Assembly Components — Type 2

Removal (All Others) — Raise and support vehicle; remove wheel. Remove caliper assembly and support out of way.

NOTE — Do not allow caliper assembly to hang from hydraulic hose. Remove Allen head screws securing rotor to wheel hub and remove rotor from hub.

Installation (All) — To install, reverse removal procedure, and tighten all nuts and bolts.

FRONT BRAKE DRUM

Removal — Raise and support vehicle, and remove wheel. Remove retainer from speedometer cable. Remove dust cap from hub, then remove wheel bearing adjusting nut, and outer wheel bearing. Back off brake shoe adjusters, and remove hub and drum assembly from vehicle.

Installation — To install, reverse removal procedure. Adjust and lubricate wheel bearings, and adjust brake shoes.

REAR BRAKE DRUM

Removal (Type 2) — Raise and support vehicle and remove wheel. With parking brake fully released, back off on brake shoe adjuster. Remove two Allen head screws and pull brake drum from wheel hub.

Removal (All Others) — Remove axle nut cotter pin, and loosen slotted axle nut. Raise and support vehicle and remove wheel. Back off brake shoe adjuster(s), and remove brake drum from vehicle using a suitable puller.

Installation (All Models) — Clean axle splines and apply a light coat of chassis lubricant to splines. To install drum, reverse removal procedure and tighten Allen head screws (Type 2), or axle nut (all others). Adjust brake shoes and parking brake.

BRAKE SHOES

Removal (Front) — Raise and support vehicle. Remove wheel, and brake drum. Remove brake shoe hold down pins and springs. Remove brake shoe return springs, and pry shoes from adjusting screws. Remove brake shoes from vehicle.

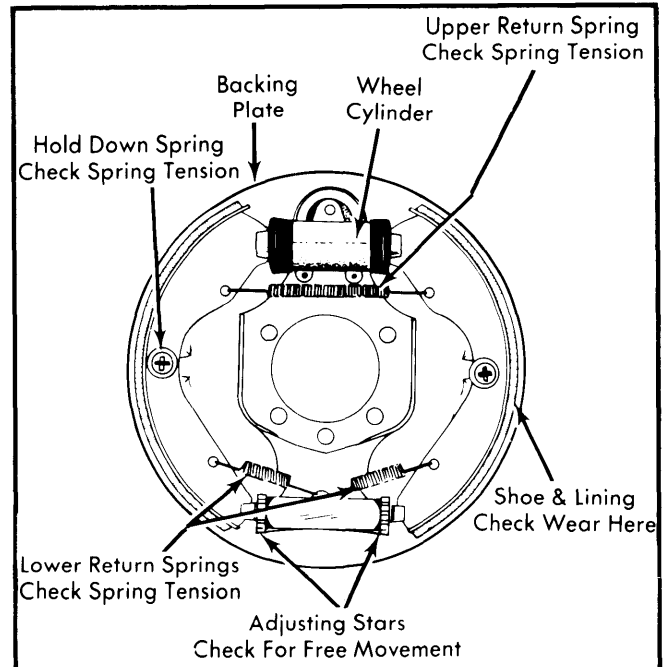

Fig. 3 Volkswagen Type 1 Front Brake Assembly

Removal (Rear) — Raise and support vehicle. Remove wheel, and brake drum. Remove brake shoe hold down pins and springs. Remove lower shoe return spring, and disconnect parking brake cable from lever. Remove brake shoes, connecting link, upper return spring, and clip from vehicle as an assembly. Separate shoes from attaching hardware.

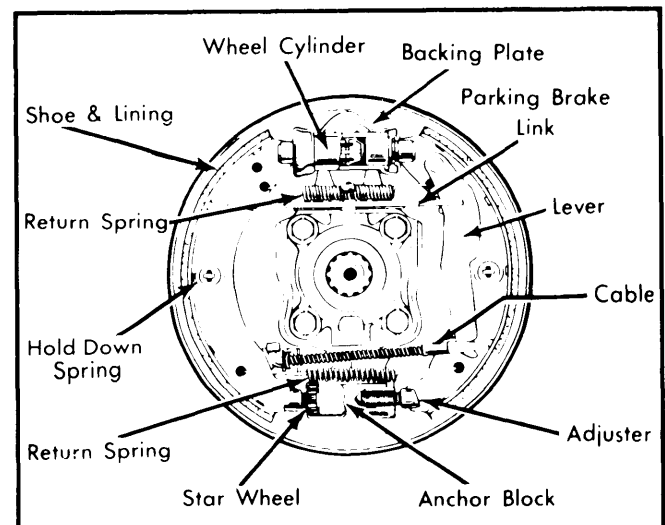

Fig. 4 Volkswagen Type 2 Rear Brake Assembly

VOLKSWAGEN (Cont.)

Installation (All Models) — To install reverse removal procedure. Adjust brakes and bleed hydraulic system if necessary.

MASTER CYLINDER

NOTE — Removal and installation of all master cylinders is basically the same. The following variations may apply: Location of cylinder, removal of wheel for accessibility, number of fluid connections, and number of electrical connections.

Removal — Drain or siphon fluid from reservoir(s). Raise and support vehicle, and remove cover plate (if equipped). Disconnect fluid lines at master cylinder. Disconnect electrical connections at cylinder, and remove push rod at brake pedal connection. Remove master cylinder attaching bolts, and remove master cylinder from vehicle. **NOTE** — If spacers are used on attaching bolts, do not allow spacers to drop into pedal assembly recess.

Installation — To install, reverse removal procedure and note the following: On vehicles equipped with a power brake unit, install a new "O" ring seal between master cylinder and power unit. After installation, bleed hydraulic system.

POWER BRAKE BOOSTER

Removal & Installation — Remove master cylinder from power brake unit. Remove vacuum hoses and cover plate, then back off push rod lock nut at power booster end. Disconnect push rod at brake pedal, pull rod to one side, and unscrew push rod from booster. Remove booster attaching hardware, and pull booster out and back. To install booster, reverse removal procedure.

OVERHAUL

NOTE — Some Dasher models may be equipped with Girling type disc brake calipers instead of Teves type as earlier models all were.

DISC BRAKE CALIPER

Disassembly (Exc. Type 2) — Remove disc pads and pry mounting frame and piston assembly off floating frame. Remove brake cylinder and guide spring from floating frame. Remove clamp and dust cap from brake cylinder, then withdraw piston. **NOTE** — If necessary, apply compressed air to fluid inlet to remove piston. Remove seal from cylinder.

Disassembly (Type 2) — Remove disc pads and retaining plates from caliper assembly, then clamp caliper mounting flange in a vice. Remove retainer and dust seal from caliper assembly. Install a suitable piston retaining tool on one piston, and place a thin rubber or wood lock between tool and piston to be removed. Carefully apply air pressure to fluid inlet port and remove piston. Remove seal from cylinder.

Inspection (All Models) — Clean all parts with clean brake fluid only. Check parts for wear or damage and replace as necessary. **NOTE** — Manufacturer recommends replacing rubber parts whenever caliper has been disassembled.

Reassembly (All Models) — To reassemble, reverse disassembly procedure and note the following: Apply brake cylinder paste to piston and cylinder. Ensure piston is not cocked in cylinder. After piston and dust seal are installed in caliper assembly, repeat procedure for remaining piston.

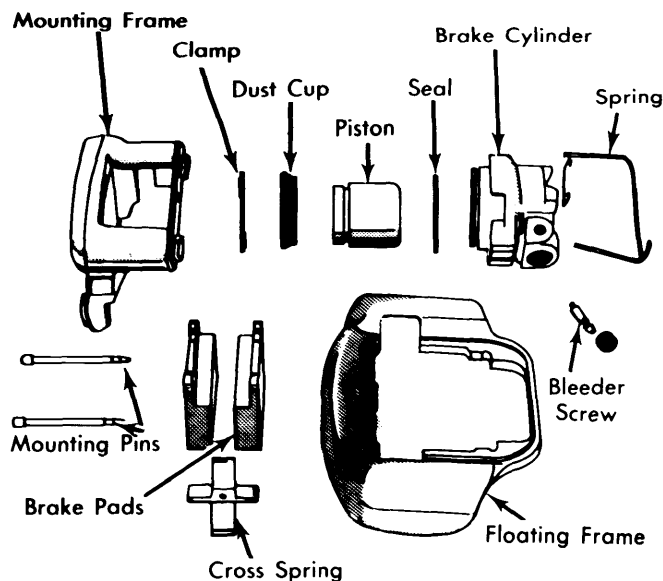

Fig. 5 Disc Brake Caliper Assembly — Dasher, Rabbit, Scirocco

WHEEL CYLINDER

Disassembly — With wheel cylinder removed from vehicle, remove dust boot(s), piston(s), expander spring, and cups.

Inspection — Clean all parts with clean brake fluid or denatured alcohol. Check piston and cylinder bore for out-of-round, corrosion, or damage.

Reassembly — To reassemble, reverse disassembly procedure, using new rubber components. Replace piston(s) and spring as necessary. Use brake cylinder paste on pistons and cups.

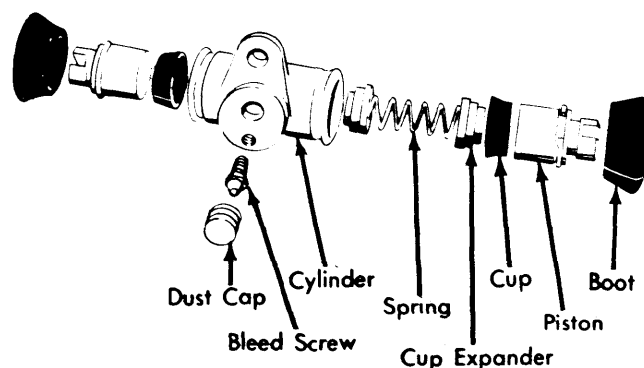

Fig. 6 Volkswagen Type 1 Wheel Cylinder Exploded View

MASTER CYLINDER

Disassembly — Remove front brake circuit piston stop screw. On Type 2 vehicles with power booster, remove snap ring and stop washer. On all other models, remove dust boot, stop ring, and stop washer. Remove both pistons and springs from cylinder by tapping open end of cylinder on a wood surface, or by carefully applying air pressure to front brake circuit fluid port will all other openings plugged. Remove all externally mounted fittings and switches from cylinder housing.

Brakes

VOLKSWAGEN (Cont.)

Inspection — Clean all parts with clean brake fluid or denatured alcohol. Check all pistons and cylinder for out-of-round, corrosion, or damage. If light honing will not remove blemishes from cylinder, replace cylinder. Inspect all other parts for scoring, wear, corrosion, or other damage.

Reassembly — 1) Install cups on pistons. Place cup washer, primary cup, support washer, spring retainer, and spring onto front piston, and insert piston assembly into cylinder bore. Assemble cup washer, primary cup, support washer, spring retainer, spring, and stop sleeve onto rear piston. Secure assembly with stroke limiting screw.

2) Except on Type 2 vehicles with power booster, install rear piston assembly into cylinder. Install stop washer, and lock ring. On Type 2 vehicles with power booster, install rear piston with washer, cup, plastic washer, second cup, and second washer into cylinder, followed by snap ring.

3) Install piston stop screw, pushing front piston assembly forward as required to clear stop screw hole. Install all externally mounted switches and fittings. Tighten all nuts and bolts.

POWER BRAKE UNIT & PRESSURE REGULATING VALVE

Replace these units as an assembly, do not try to overhaul units. When installing booster, use new boot, filter, damping washer, and sealing ring.

TIGHTENING SPECIFICATIONS	
Application	Ft. Lbs. (mkg)
Master Cylinder-to-Booster	9 (1.3)
Master Cylinder-to-Frame	18 (2.5)
Piston Stop Screw	4-7 (.5-1.0)
Stop Light Switch	14 (2)
Caliper Mounting Bolts	
Type 2	116 (16)
Dasher, Rabbit, Scirocco	43 (6)
Slotted Axle Nut	253 (35)

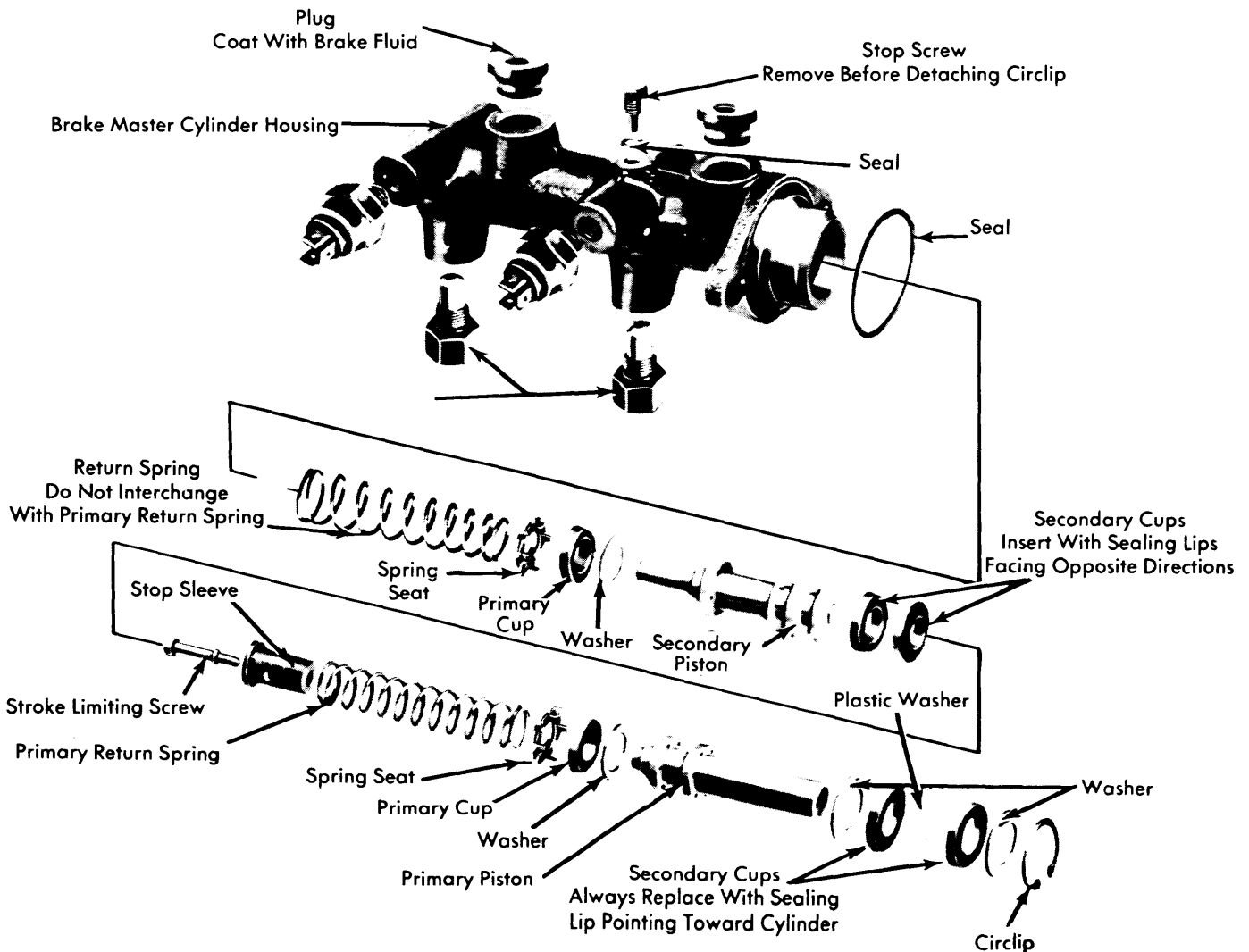

Fig. 7 Master Cylinder Component Relationship — Rabbit, Scirocco, Dasher

VOLKSWAGEN (Cont.)

BRAKE SYSTEM SPECIFICATIONS				
Application	Drum Diam.	Wheel Cylinder Diameter		Master Cylinder Diameter
		Front	Rear	
Type 1 Sedan	9.055 (230)	.874 (22.2)	.678 (17.5)	.750 (19.05)
All Others937 (23.8)	.678 (17.5)	.750 (19.05)
Type 2	9.921 ^① (252)	②	.937 (23.8)	.874 (22.2)
Dasher	7.87 ^① (200)	②813 (20.6)
Rabbit & Scirocco	7.1 (180)	②

- ① - Rear Drum.
② - Front Disc Brake.

DISC BRAKE ROTOR SPECIFICATIONS						
Application	Disc Diameter	Lateral Runout	Parallelism	Original Thickness	Minimum Refinish Thickness	Discard Thickness
Type 2	10.95 (278)	.004 (.10)	.0008 (.02)	.512 (13)	.472 (12)	.452 (11.5)
Dasher	9.41 (239)	.004 (.10)	.0008 (.02)	.472 (12)	.433 (11)	.410 (10.5)
Rabbit & Scirocco472 (12)	.433 (11)	.410 (10.5)

BRAKE DRUM SPECIFICATIONS				
Application	Drum Diameter	Original Diameter	Maximum Refinish Diameter	Discard Diameter
Front Type 1 (Exc. Sedan)	9.768 (248)	9.768 (248)	9.823 (249.5)	...
Sedan	9.055 (230)	9.055 (230)	9.114 (231.5)	...
Rear Type 1	9.055 (230)	9.055 (230)	9.114 (231.5)	...
Dasher	7.87 (200)	7.87 (200)	7.89 (200.5)	7.91 (201)
Rabbit & Scirocco	7.08 (180)	7.08 (180)	7.10 (180.5)	7.125 (181)