

MERCEDES BENZ

230
240D
280
300
450

DESCRIPTION

All models incorporate four wheel disc brake systems. Brakes are manufactured by either Bendix or Teves. Disc brake calipers are actuated by a power assisted, dual piston master cylinder. Parking brakes are cable actuated, internal expanding shoe type. Rear brake rotors house parking brake shoes.

ADJUSTMENT

DISC BRAKES

Disc brakes are self-adjusting, therefore no adjustment in service is required.

PARKING BRAKE

Remove one wheel lug bolt at each rear wheel. Raise and support vehicle, and rotate wheels until lug bolt hole is positioned over parking brake adjuster (approximately 45° in upward and forward direction from wheel center). Using a screwdriver inserted through lug bolt hole, turn adjuster until wheel cannot be turned by hand. Back off adjuster until wheel can be turned by hand without restriction.

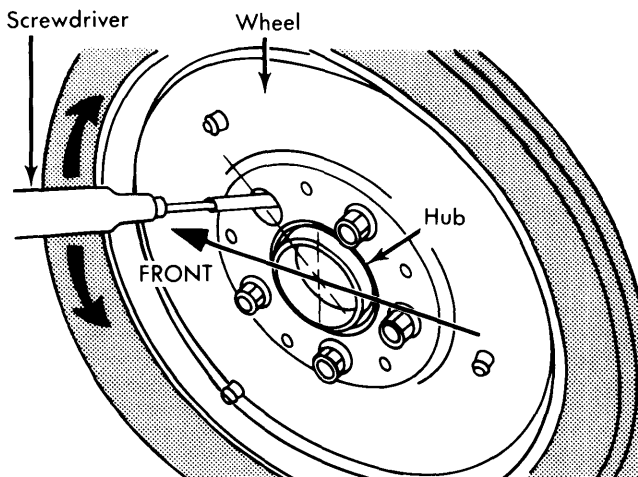

Fig. 1 Fitting Parking Brake Adjuster Tool Into Adjusting Mechanism

HYDRAULIC SYSTEM BLEEDING

Beginning with cylinder farthest from master cylinder, attach one end of bleeder tube to bleeder screw, and submerge opposite end in a jar half full of clean brake fluid. Pump brake pedal several times, and with pedal at bottom of stroke, open bleeder screw. Close bleeder screw when fluid stops flowing from tube, then release pressure on brake pedal. Repeat procedure until fluid flowing from tube shows no sign of air.

REMOVAL & INSTALLATION

DISC PADS

Removal — Raise and support vehicle with safety stands, remove wheels. If equipped, remove shaft cover plate from caliper. Drive out retaining pins toward inside of vehicle and

remove cross spring. Using a suitable extractor tool, remove disc pads from caliper assembly.

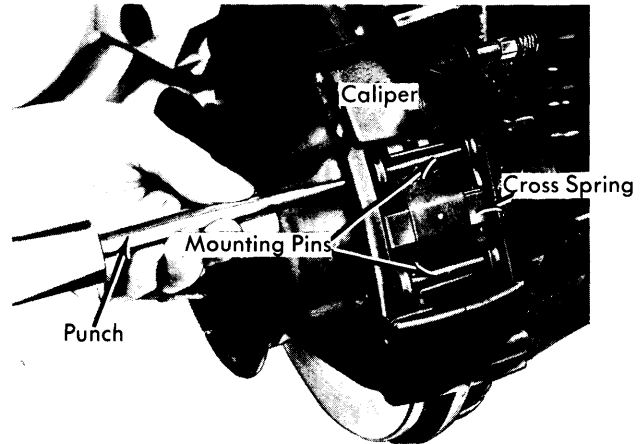

NOTE — Drive Pin In Toward Vehicle

Fig. 2 Knocking Out Disc Pad Mounting Pins On Teves Model Brakes

Installation — Using a cylinder brush, clean disc pad guide surface in caliper. Siphon sufficient fluid from master cylinder reservoir to prevent overflowing, then press pistons to bottom of bores. Install disc pads, cross spring, retaining pins and cover plate (if equipped). After installation, depress brake pedal several times to position pads against rotor.

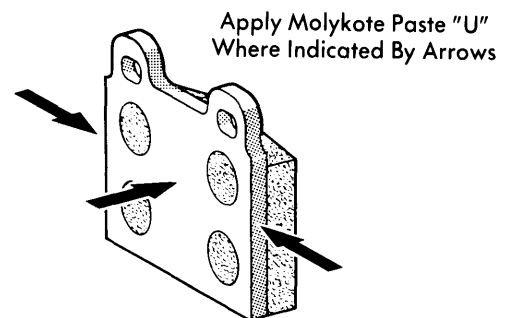

Fig. 3 Typical Mercedes Benz Disc Brake Pad Illustration Shows Molykote Application Points.

BRAKE CALIPER

Removal — Raise and support vehicle, and remove wheel. Disconnect brake lines at caliper assembly, and plug lines to prevent entry of foreign matter. Remove caliper attaching bolts, and remove caliper assembly from vehicle.

Installation — To install caliper assembly, reverse removal procedure. Tighten all nuts and bolts, and bleed hydraulic system.

BRAKE ROTOR

Removal & Installation (Front) — With caliper assembly removed, remove hub grease cap. Remove contact spring for radio shielding, loosen socket screw on clamping nut on wheel

MERCEDES BENZ (Cont.)

spindle, remove clamping nut and washer, then remove wheel hub and rotor assembly. Remove Allen head bolts securing rotor to hub and remove rotor. To install, reverse removal procedure, tighten all bolts and fittings evenly, and bleed hydraulic system if necessary. Adjust front wheel bearing. See *Wheel Bearing Adjustment* in **WHEEL ALIGNMENT** Section.

Removal & Installation (Rear) — Remove rear wheel and caliper assembly, then pull rotor out from axle shaft flange. To install, reverse removal procedure, tighten all bolts and fittings evenly, and bleed hydraulic system if necessary.

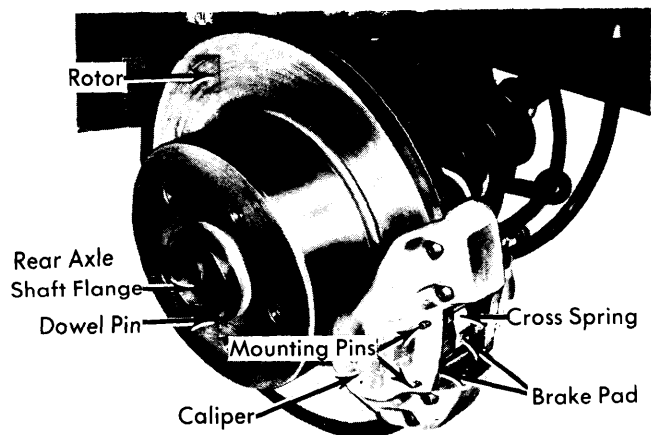

Fig. 4 Assembled View of Rear Hub and Caliper

MASTER CYLINDER

Removal — Drain master cylinder of brake fluid. Disconnect and plug brake lines, disconnect electrical wires. Remove bolts securing master cylinder to power booster and remove master cylinder.

Installation — Reverse removal procedure and note the following: Always replace rubber "O" ring seal between master cylinder and power unit. Bleed hydraulic system and check complete system for fluid leaks.

POWER BRAKE UNIT

Removal — Drain master cylinder brake fluid, and remove master cylinder from vehicle. Disconnect vacuum line at power booster, and disconnect push rod at brake pedal. Remove power brake unit attaching hardware, and remove assembly from vehicle.

Installation — To install, reverse removal procedure, tighten all nuts and bolts, and bleed hydraulic system.

OVERHAUL**BRAKE CALIPER**

Disassembly — With caliper removed from vehicle and disc pads removed from caliper, remove dust cap from piston housing. Hold one piston in place using a suitable clamp, then apply compressed air to fluid inlet and remove opposite piston. Remove piston seal from groove of cylinder bore. Remove remaining piston and seal in same manner. **CAUTION** — Do not separate caliper halves.

Cleaning & Inspection — Remove deposits on piston with a soft brass wire brush. **NOTE** — Do not use polishing or emery cloth on pistons, as they could damage chrome plated surface. Check cylinder bore of caliper for wear or damage. Small rust spots in bore can be removed with polishing cloth and heavier rust spots in front of piston seal groove with fine emery paper.

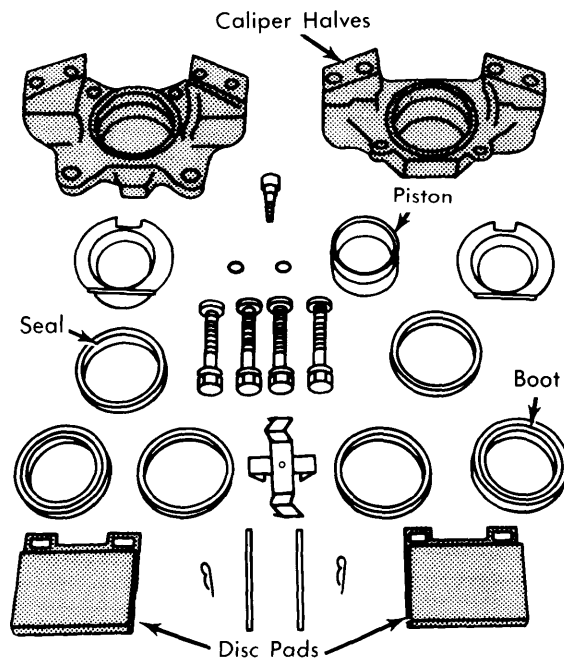

Fig. 5 Disassembled View of Typical Mercedes Benz Brake Caliper

Reassembly — Coat piston and caliper bore with ATE brake cylinder paste (or equivalent), install piston seal into groove of bore, then install piston. **NOTE** — Install piston so that elevation on piston is facing downward. Install dust cap. Install heat shield into piston with recess in shield fitting into elevation of piston. **NOTE** — Elevation should project at least .004" (.1 mm) above shield.

MASTER CYLINDER

Disassembly — Remove fluid reservoir from master cylinder. Remove check valves from cylinder housing. Push piston into cylinder bore slightly, and remove forward piston stop screw. Remove lock ring from open end of cylinder bore. Remove rear piston, washer, seals, and rings from cylinder. Remove front piston and spring from cylinder. Disassemble front piston by removing connecting screw.

Inspection — Clean all parts with alcohol or brake fluid. Check bore in housing and piston for scoring and rust. Small rust spots in housing may be removed with polishing cloth. Scored or badly rusted parts cannot be repaired, replace complete master cylinder.

Reassembly — Reverse disassembly procedure and bleed hydraulic system.

TIGHTENING SPECIFICATIONS

Application	Ft. Lbs. (mkg)
Front Caliper Mounting Bolts.....	83 (11.5)
Rear Caliper Mounting Bolts.....	65 (9)
Master Cylinder Attaching Bolts.....	9-10 (1.2-1.4)
Rotor-to-Wheel Hub Bolts.....	83 (11.5)
Hydraulic Line Fittings.....	11 (1.5)

MERCEDES BENZ (Cont.)

- 1 Container plug
- 3 Piston (push rod circuit)
- 4 Stop washer
- 5 Locking ring
- 6 Vacuum seal
- 7 Intermediate ring
- 8 Bearing ring
- 9 Filling washer
- 10 Primary sleeve
- 11 Supporting ring
- 12 Spring retainer
- 14 Connecting screw
- 15 Stop screw
- 17 Compression spring
- 18 Ring sleeve
- 19 Spring plate
- 20 Piston(intermediate piston)
- 21 Compression spring
- 22 Housing
- 23 Splash guard
- 24 Strainer
- 25 Closing cover
- 26 Compensating tank
- 27 Contact insert
- 28 O-ring
- 29 End cover
- 30 Float
- 31 Sealing ring
- A Leak hole
- B Filler hole
- C Compensating hole

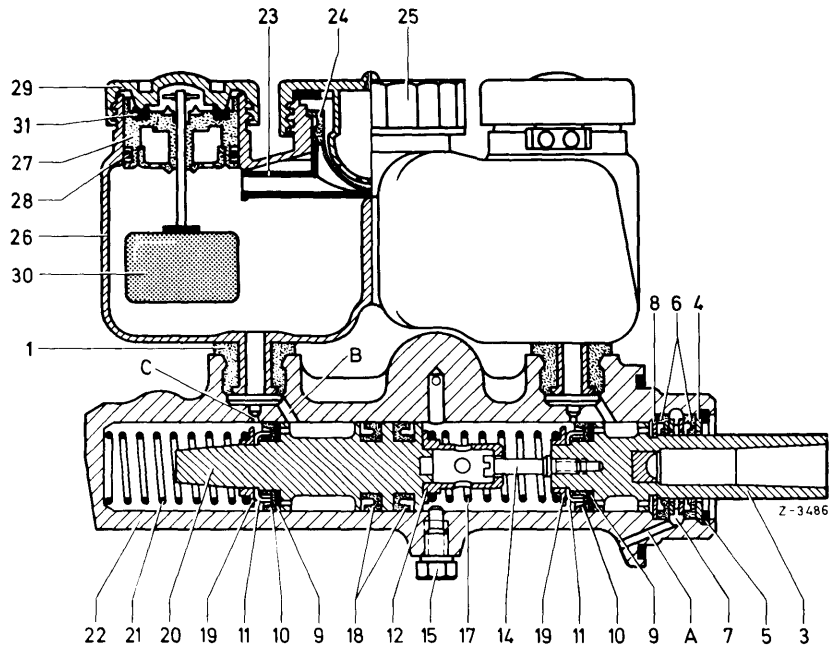

Fig. 6 Sectional View of Late Model Mercedes Benz Tandem Master Cylinder

DISC BRAKE ROTOR SPECIFICATIONS							
Application	Disc Diameter In. (mm)	Lateral Runout In. (mm)	Parallelism In. (mm)	Original Thickness In. (mm)	Minimum Refinish Thickness In. (mm)	Discard Thickness In. (mm)	
230 & 240D	Front	10.75 (273)	.0047 (.12)	.0008 (.02)	.496 (12.6)	.457 (11.6)	.435 (11.05)
	Rear	10.98 (279)	.0059 (.15)	.0008 (.02)	.394 (10)	.370 (9.4)	.355 (9.02)
280 Models	Front	10.94 (278)	.0047 (.12)	.0008 (.02)	.496 (12.6)	.457 (11.6)	.435 (11.05)
	Rear	10.98 (279)	.0059 (.15)	.0008 (.02)	.394 (10)	.370 (9.4)	.355 (9.02)
450 Models	Front	10.94 (278)	.0047 (.12)	.0004 (.01)	.866 (22)	.827 (21)	.815 (20.7)
	Rear	10.98 (279)	.0059 (.15)	.0004 (.01)	.394 (10)	.370 (9.4)	.355 (9.02)