

JAGUAR

XJ6 Sedan
XJ12 Sedan

DESCRIPTION

Brake system utilizes four wheel disc brakes and a tandem master cylinder connected to a power brake unit (servo). Front calipers are four piston type. Master cylinder provides separate hydraulic circuits for front and rear calipers. A pressure differential warning system is used and employs a self-centering shuttle. Front calipers are mounted on stub axle carriers and rear calipers are mounted inboard on differential housing, with rotors connected to differential drive shaft flanges. Each front caliper consists of four pistons (two outboard and two inboard), and each rear caliper consists of two opposing pistons. Parking brake consists of independent lever-operated calipers mounted on the rear service brake calipers. Parking brake calipers operate on service brake rotors.

ADJUSTMENT

DISC BRAKE PADS

Due to self-adjusting feature of calipers, no adjustment in service is required.

PARKING BRAKE

Parking Brake Caliper — Caliper is self-adjusting to compensate for pad wear, therefore, no adjustment is required.

Parking Brake Cable — Fully release lever. Loosen front yoke lock nut, and remove clevis pin securing yoke to bell crank lever. Ensure calipers are fully released. Turn back yoke on adjuster rod so a slight amount of slack is present when yoke is connected to lever. **CAUTION** — Binding may result if all slack is removed from cable. Connect yoke to lever, secure with clevis pin, and tighten lock nut.

HYDRAULIC SYSTEM BLEEDING

Keep hydraulic fluid reservoirs filled with clean brake fluid during bleeding operation. Attach a bleed tube to bleeder screw on left-rear brake caliper, and immerse opposite end of tube in a container partially filled with brake fluid. Loosen bleeder screw, operate pedal through full stroke until discharged fluid is free of air bubbles, and close bleeder screw. Repeat procedure on right-rear caliper and front calipers. Refill brake fluid reservoirs and check system for leaks.

REMOVAL & INSTALLATION

DISC PADS (SERVICE BRAKES)

Removal — Raise vehicle and remove wheels. Remove pin clips, pad retaining pins, anti-chatter springs (if equipped) and lining pads.

Installation — Draw out about half the brake fluid from reservoir(s). This will enable caliper pistons to be pushed back into cylinders without overflowing fluid. Lever pistons back, insert new pads, springs and replace retaining pins and clips. Check pads for freedom of movement within caliper. Check reservoirs for correct fluid level.

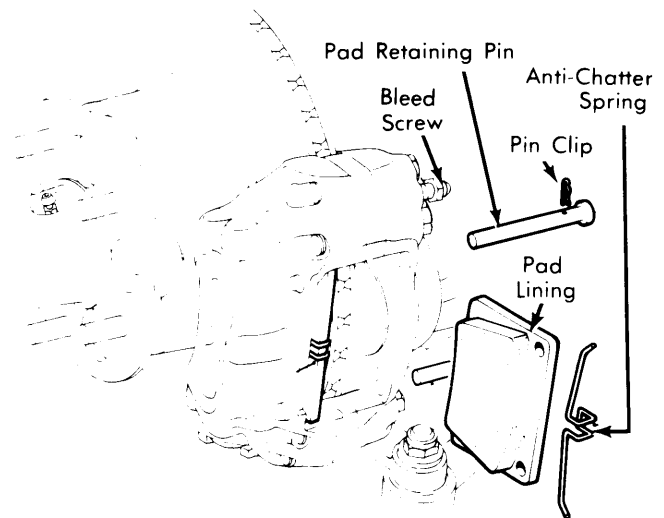

Fig. 1 Front Brake Caliper with Detail of Pad Removal

DISC PADS (PARKING BRAKE)

Removal & Installation — Parking brake calipers must be removed to replace disc pads. See *Parking Brake Caliper Removal & Installation*.

PARKING BRAKE CALIPER

Removal — Raise and support vehicle. Remove nuts and bolts attaching rear suspension mounting plate to rear suspension unit and remove plate from vehicle. Disconnect parking brake cable and return spring from caliper. Remove caliper mounting bolts and retraction lever, then slide caliper around rotor and remove through hole left by removal of suspension mounting plate. To remove disc pads, remove nut and spring washer securing pads to pad carriers and lift out pads.

Installation — To install, reverse removal procedure and note the following: If new pads are installed, or if caliper has been overhauled, adjust caliper by holding one pad carrier stationary and turning remaining carrier until there is a clearance of .75" (19.05mm) between disc pad surfaces. With caliper installed on rotor, but mounting bolts not installed, operate actuating lever until adjuster ratchet ceases to click, this will properly adjust pad clearance. Install remaining components and check operation of parking brake.

JAGUAR (Cont.)

SERVICE BRAKE CALIPER

NOTE — Do not separate caliper halves for repair, if a leak exist between halves, replace caliper.

Removal (Front) — Raise vehicle and remove wheels. Disconnect caliper fluid line and plug. Discard locking wire from mounting bolts, remove nuts and caliper. **NOTE** — Check position and number of shims between steering arm and caliper, if equipped with shims replace in same order.

Installation — Place caliper in position, install shims if equipped, secure bolts and lock with wire. Connect fluid line and bleed brakes.

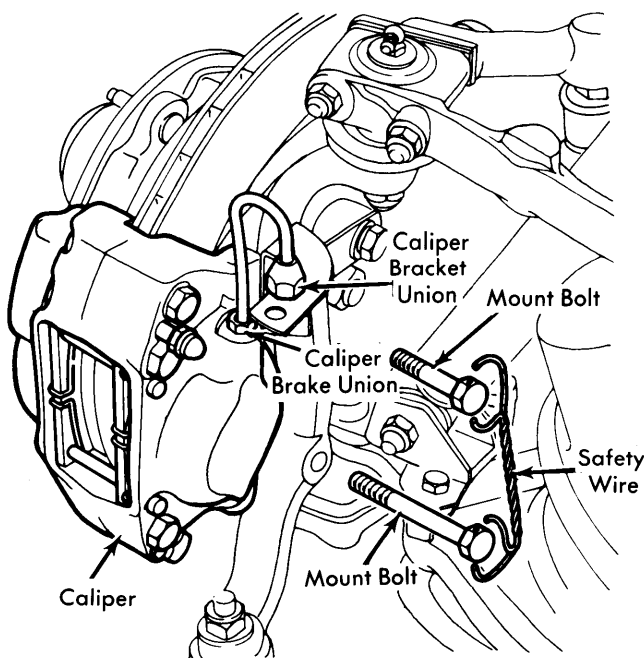

Fig. 4 Assembled View of Disc Brake Caliper with Detail for Removing

Removal (Rear) — Remove parking brake caliper and disc pads as previously outlined. Disconnect and plug hydraulic brake line from caliper and remove caliper mounting bolts lock wire. Remove mounting bolts, then slide caliper downward and remove from vehicle.

Installation — Place caliper in position, install shims if equipped, and secure bolts. Torque bolts to 49-55 ft. lbs. Check rotor for center between caliper. If necessary, adjust shims between drive flange and rotor. If shim adjustment is performed, rear wheel camber must be checked. See *Jaguar Rear Wheel Camber Adjustment* in **WHEEL ALIGNMENT** Section. Complete installation by reversing removal procedures.

BRAKE ROTOR

Removal (Front) — Remove brake caliper disc pads as previously outlined. Remove hub-to-rotor attaching bolts and washers. Remove hub dust cap, then remove cotter pin, axle nut and washer from axle stub and remove hub. Insert a punch

through access hole in splash shield and lightly tap on it to free water deflector. Remove rotor assembly by sliding it from caliper jaws and over axle stub.

Installation (Front) — To install, reverse removal procedure and note the following: Pack hub and wheel bearings with suitable grease and adjust wheel bearing end play. See *Wheel Bearing Adjustment* in **WHEEL ALIGNMENT** Section.

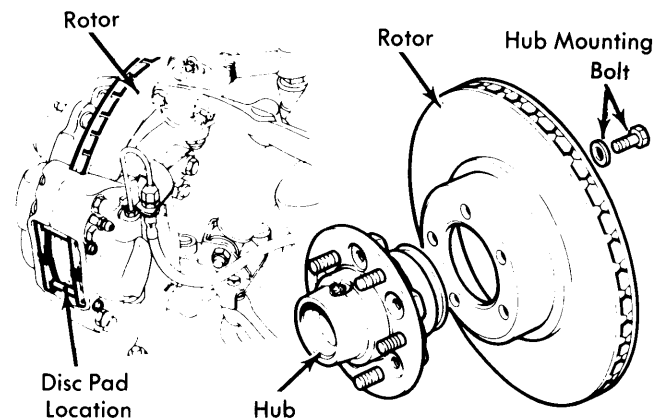

Fig. 5 Assembled View of Rotor and Detail of Hub and Rotor Separation

Removal (Rear) — Remove brake caliper as previously outlined. Disconnect shock absorber from lower mount and remove radius arm locking bolt and lower control arm outer grease fitting. Place stands under hub assembly and slide radius arm from anchor point. Loosen clamp and slide boot away from inner universal joint, then remove universal joint-to-rotor attaching bolts and separate universal joint from rotor. **NOTE** — Check number and position of camber shims between universal joint and rotor. Raise vehicle and remove rotor.

Installation (Rear) — To install, reverse removal procedure and note the following: Ensure caliper is centered on rotor; adjust by adding or removing shims from between rotor and axle housing output flange. Check rear wheel camber and adjust if necessary. See *Camber Adjustment* in **WHEEL ALIGNMENT** Section.

MASTER CYLINDER

Removal & Installation — Drain brake fluid reservoir, disconnect hydraulic lines and mark location for reassembly reference. Remove nuts and washers retaining cylinder to servo unit, remove vacuum line retaining strap, and separate cylinder from servo. To install, reverse removal procedure and bleed hydraulic system.

Installation — Reverse removal procedure and note following: Install new copper gaskets on fluid line fittings. Check brake pedal for free travel, .125" (3.17 mm), before resistance of master cylinder piston is felt. Adjust with lock nut on push rod. Check brake light switch for proper operation.

JAGUAR (Cont.)

SERVO ASSEMBLY

Removal & Installation (XJ6 & XJ12) – Remove right air cleaner and disconnect choke cable from right-front carburetor. Disconnect hydraulic lines and vacuum line. Disconnect electrical leads from fluid level warning switch. Remove reservoir and bracket assembly from pedal box. Remove nuts securing pedal box vertical mounting to firewall, lift heater vacuum pipe clear of studs, remove brake light switch, and remove bolts securing pedal box base mounting to firewall. Lift out pedal box, servo unit, and master cylinder as an assembly. Remove nuts securing servo to pedal box, remove rubber sealing plugs and remove clevis pin connecting servo operating rod to brake pedal lever. To install, reverse removal procedure and bleed hydraulic system.

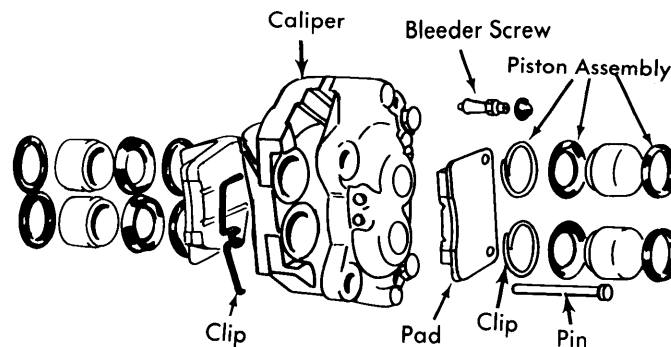

Fig. 2 Expanded View of Front Disc Brake Caliper

OVERHAUL

BRAKE CALIPER

NOTE – DO NOT separate caliper halves for service; pistons and seals may be changed without splitting caliper. If a leak is detected between caliper halves, replace caliper as a unit.

Disassembly – With disc pads removed, install a suitable piston clamp to retain outboard piston(s), then apply compressed air to fluid inlet port and remove inboard piston(s). Pull dust seal from piston(s) and caliper grooves. Carefully remove piston seal from cylinder. **NOTE** – Inboard piston(s) must be installed before outboard piston(s) can be removed.

Cleaning & Inspection – Clean all parts in alcohol and inspect for wear or damage. Check cylinder bore and pistons for scratches, rust or corrosion; replace all damaged parts.

Reassembly – Coat cylinder, piston and seal with brake fluid before installing. Place piston seal in bore. Install dust seal over cylinder groove and carefully insert piston through dust seal. Pull dust seal into groove in piston. Use piston clamp to press piston completely into cylinder. Repeat procedure for outer piston seal replacement. Install caliper as previously outlined.

MASTER CYLINDER

Disassembly – With master cylinder removed from vehicle, carefully pry hose adaptors from sealing grommets and grommets from master cylinder. Push in on primary piston and remove secondary piston stop pin from forward grommet housing. Remove spring lock, then tap flange end of cylinder to remove primary and secondary piston assemblies. Disassemble springs, spring seats, seals and washers from piston assemblies.

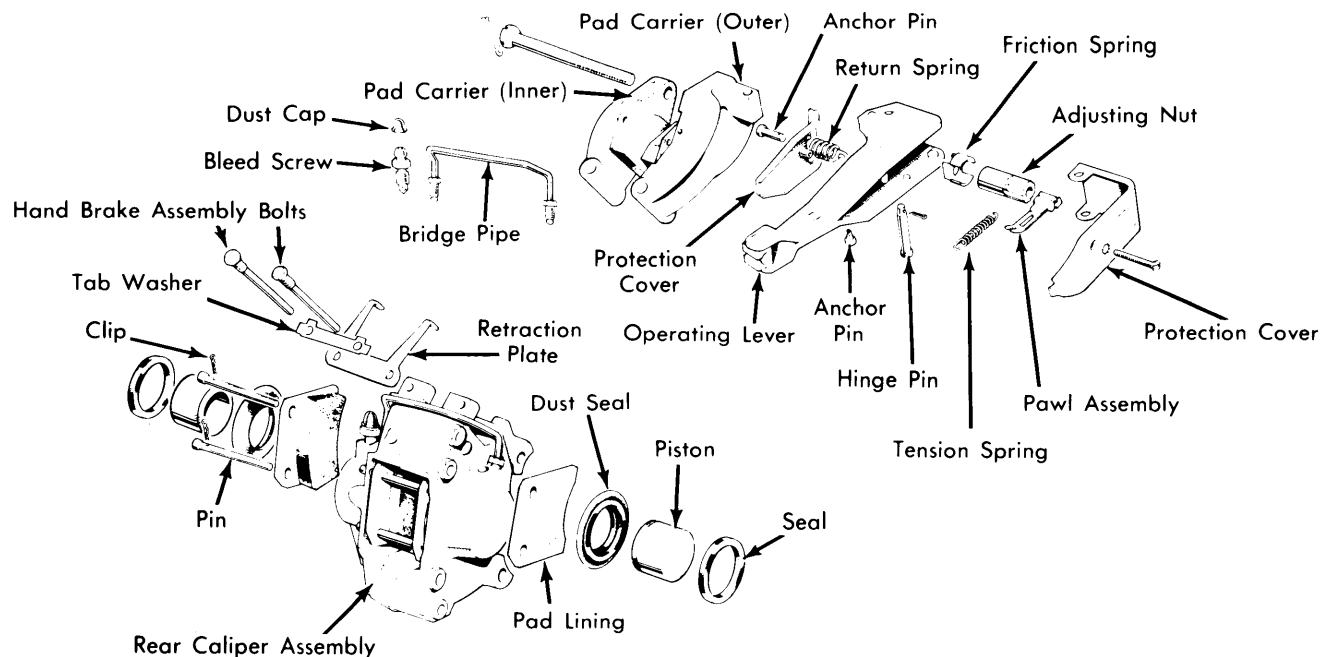

Fig. 3 Exploded View of Rear Disc Brake Caliper with Detail of Parking Brake Assembly

JAGUAR (Cont.)

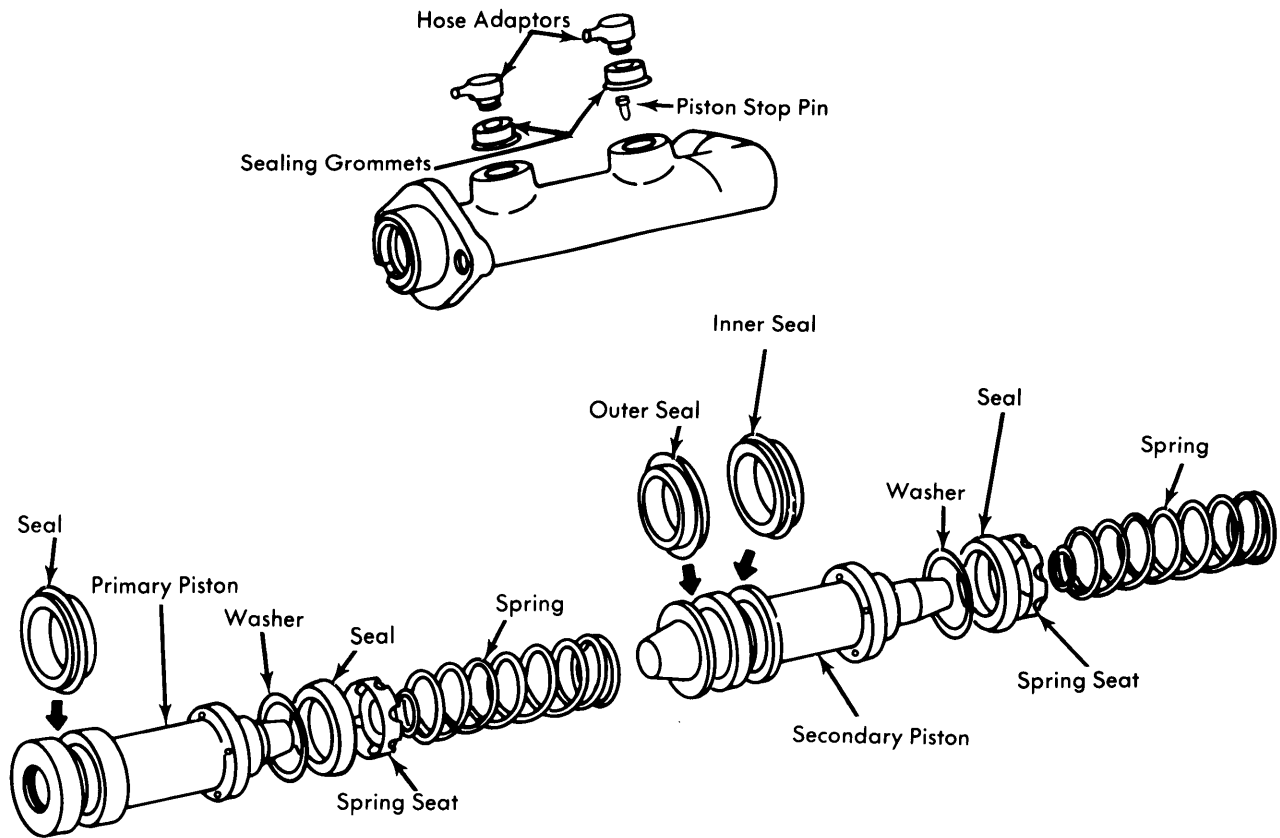

Fig. 6 Exploded View of Jaguar Dual Piston Master Cylinder

Cleaning & Inspection – Clean all parts in alcohol and dry with a lint-free cloth. Inspect pistons and bore for wear, scores, or corrosion; replace damaged parts as necessary.

Reassembly – To reassemble, reverse disassembly procedure and note the following: Lubricate all parts with clean brake fluid. Install secondary piston inner seal with lip facing away from primary piston and install outer seal with lip facing primary piston. Install primary piston seal with lip facing away from spring lock. Install master cylinder and bleed brake system.

TIGHTENING SPECIFICATIONS	
Application	Ft. Lbs. (mkg)
Pedal Box-to-Body	11-13 (1.5-1.8)
Caliper Mounting Bolts	
Front.....	50-60 (7.0-8.3)
Rear.....	49-55 (6.7-7.6)
Wheel Lug Nuts	40-60 (5.5-8.3)

DISC BRAKE ROTOR SPECIFICATIONS						
Application	Disc Diameter In. (mm)	Lateral Runout In. (mm)	Parallelism In. (mm)	Original Thickness In. (mm)	Minimum Refinish Thickness In. (mm)	Discard Thickness In. (mm)
All Models						
Front	11.18 (284)	.004 (.1)950 (24.1)
Rear	10.38 (263.5)	.004 (.1)500 (12.7)