

## CAPRI

### Capri II

### DESCRIPTION

The brake system is hydraulically operated, utilizing a tandem master cylinder and a power brake booster. Front disc brakes consists of rotors attached to wheel hubs, and dual piston floating caliper assemblies. Rear brakes are leading-trailing shoe/drum type, using a dual piston wheel cylinder. A pressure differential valve is used to distribute correct pressure to each rear brake wheel cylinder. Parking brake system is cable and rod operated, acting on rear brake assemblies.

### ADJUSTMENT

#### FRONT DISC BRAKE PADS

Front disc brakes are self-adjusting, therefore, no adjustment in service is required.

#### REAR BRAKE SHOES

Rear drum brakes are self-adjusting (actuated by parking brake linkage), therefore, no adjustment in service is required.

#### PARKING BRAKE LINKAGE

**NOTE** — It should only be necessary to adjust parking brake system in the event of wear on linkage components or replacement of parts. **DO NOT** adjust for rear brake wear.

Ensure parking brake is fully released, then raise and support vehicle. To adjust primary cable, engage keyed sleeve (A) into abutment slot (B), then turn adjuster nut (C) until all slack is removed from cable. Parking brake is properly adjusted when clearance between parking brake lever stop and brake backing plate is .039-.059" (1.0-1.5 mm).

#### BLEEDING HYDRAULIC SYSTEM

1) Fill master cylinder reservoir with brake fluid and maintain level throughout bleeding operation. **NOTE** — Piston in pressure differential valve is self centering and does not need to be held in central position while the brakes are being bled. Attach a hose to right front brake bleeder screw and immerse opposite end in a container partially full of brake fluid.

2) Open bleeder screw approximately one-half turn, depress brake pedal fully, then allow it to return to its off position. Continue depressing brake pedal, pausing after each return stroke to allow full recuperation of master cylinder, until fluid entering container is clean and free from air bubbles. Press brake pedal to the floor and hold it there while bleeder screw is tightened. Repeat operation on remaining brakes in the following sequence: left front, left rear and right rear.

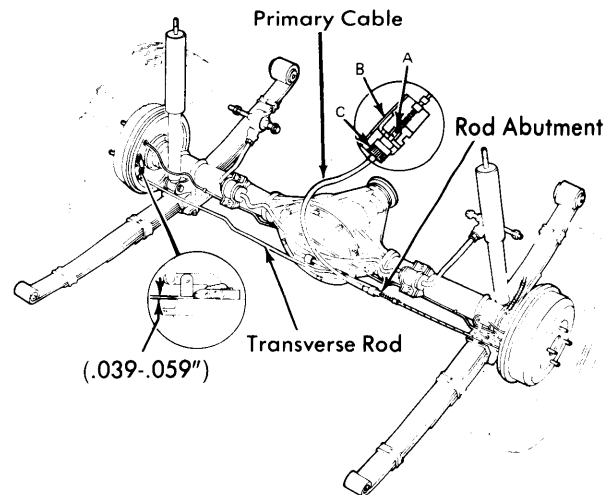

Fig. 1 Parking Brake Adjustment Points

### REMOVAL & INSTALLATION

#### FRONT DISC BRAKE PADS

**Removal** — Remove retaining pin clips and pins. Lift-out brake pads, tension springs and shim, (if equipped). **NOTE** — Clean any foreign matter from rotor. Ensure new pads are correct.

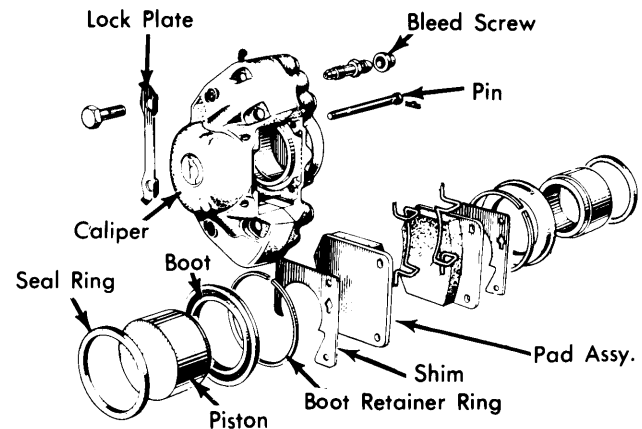

Fig. 2 Exploded View of Front Disc Brake Assembly

**Installation** — Press pistons to bottom of caliper bores. **NOTE** — Siphon sufficient fluid from master cylinder to prevent overflowing when pistons are pressed back into bores. Place tension springs on brake pads and shims, then install pads and shims into caliper assembly with arrow on shims pointing up. Install retaining pins and secure with pin clips. Pump brake pedal several times to position pads against rotor.

## CAPRI (Cont.)

## FRONT DISC BRAKE CALIPER

**Removal** — With disc pads removed from caliper, disconnect hydraulic line from caliper and plug openings. Bend up lock tabs, remove caliper retaining bolts, and detach caliper assembly.

**Installation** — Position caliper on steering knuckle, install new lock tabs, then install and tighten retaining bolts. Install disc pads and bleed hydraulic system.

## FRONT DISC BRAKE ROTOR

**Removal** — With caliper assembly removed, remove dust cap, cotter pin, adjusting nut, thrust washer, and outer bearing. Remove hub and rotor assembly, bend back lock tabs, remove attaching bolts, and separate rotor from hub. Discard lock tabs and bolts.

**Installation** — Thoroughly clean mating surfaces of hub and rotor, position rotor on hub aligning mating marks, and install and tighten lock tabs and retaining bolts. To complete installation, reverse removal procedure, tighten all bolts evenly and adjust wheel bearings. See *Wheel Bearing Adjustment in WHEEL ALIGNMENT* Section.

## REAR BRAKE SHOES

**Removal** — Raise and support vehicle and remove rear wheels. Ensure parking brake is fully released, then remove brake drum. Remove brake shoe hold down springs and pins, then pull shoes from bottom guides and remove lower spring. Pull primary shoe from wheel cylinder slot and self-adjuster arm, then undo spring and remove shoe. Unhook secondary shoe from parking brake lever, disconnect spring and remove shoe.

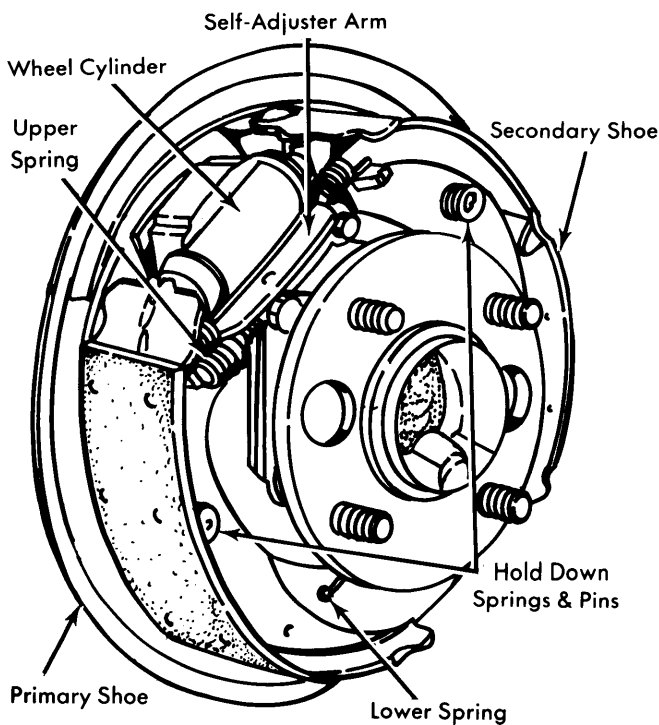

Fig. 3 Assembled View of Rear Drum Brake Components

**Installation** — Hook spring and parking brake lever to secondary shoe. Connect upper spring to both shoes and position primary shoe over self-adjuster arm. Connect lower spring to shoes, then install lower end of shoes into guides. Install hold down springs and pins. Ensure brakes are centered and install brake drum.

## REAR BRAKE WHEEL CYLINDER

**Removal** — Remove wheel, drum and brake shoe assemblies. Ensure there is no vacuum in booster system, then disconnect brake line from wheel cylinder. Remove wheel cylinder attaching bolts and lock washers and remove cylinder.

**Installation** — Place wheel cylinder into position, then connect brake line to cylinder and tighten fitting finger tight. Install and tighten cylinder attaching bolts with lock washers, then tighten brake line fitting. Install links in ends of cylinder, then install shoe and adjuster assemblies. Install brake drum and bleed hydraulic system.

## MASTER CYLINDER

**Removal** — Siphon fluid from reservoir, then disconnect hydraulic lines from master cylinder. Remove master cylinder-to-booster attaching nuts, then lift master cylinder from booster using care not to damage vacuum seal.

**Installation** — Position master cylinder and fluid seal onto push rod and start all brake line union nuts. Connect master cylinder to booster and tighten attaching nuts. Tighten brake line union nuts and fill master cylinder with brake fluid. Bleed hydraulic system and check operation of brakes.

## POWER BRAKE UNIT

**Removal** — Disconnect power unit push rod from brake pedal. Remove nuts retaining master cylinder to power unit and position master cylinder out of way. Remove vacuum hose from power unit, power unit-to-firewall retaining screws, and remove power unit from vehicle. Remove retaining bracket and gasket from power unit.

**Installation** — Reverse removal procedure and note the following: Assemble retaining bracket to power unit using a new gasket. Make sure seal ring is installed on master cylinder between cylinder and power unit.

## PRESSURE DIFFERENTIAL VALVE

**Removal** — Disconnect the five brake fluid lines from ports on valve and plug ends of the two lines from master cylinder. Disconnect electrical wiring from warning switch. Remove bolt attaching valve to left side of engine compartment and lift out valve.

**Installation** — Position valve in place in engine compartment and loosely install attaching bolt. Reconnect brake lines, then tighten attaching bolt. Fill master cylinder reservoir with brake fluid and bleed hydraulic system.

## CAPRI (Cont.)

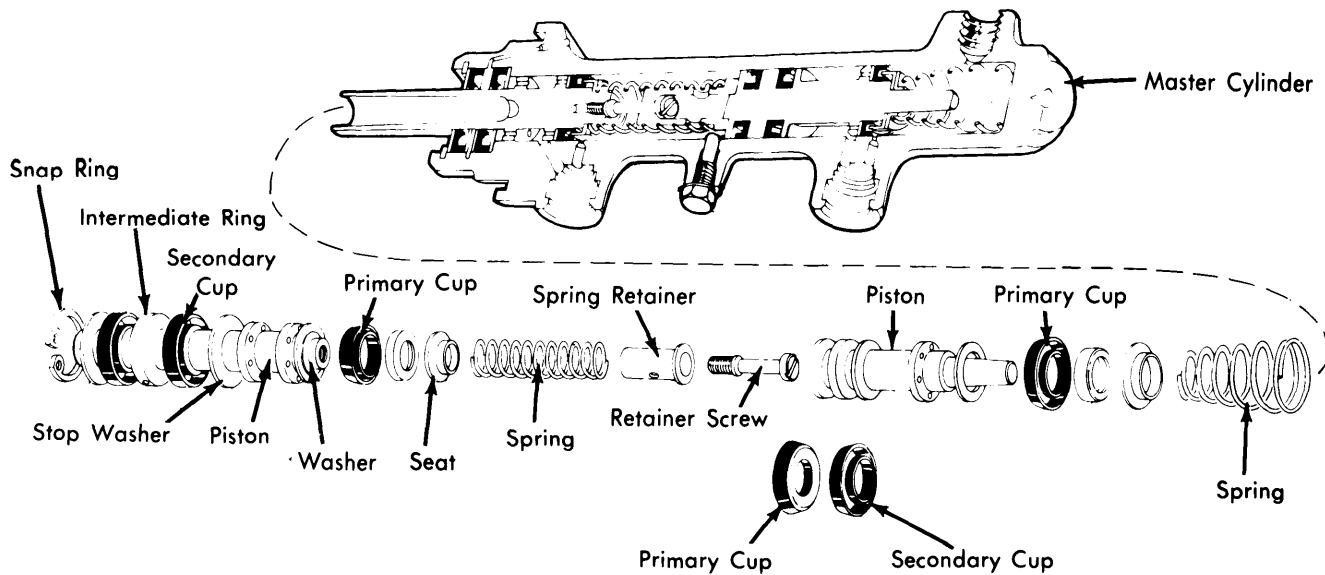

Fig. 4 Exploded View of Master Cylinder and Related Components

## OVERHAUL

### FRONT DISC BRAKE CALIPER

**Disassembly** — Partially remove one piston from cylinder bore, remove snap ring, and remove sealing bellows from piston skirt. Remove piston by applying air pressure or hydraulic pressure to fluid inlet in caliper. Remove sealing bellows from annular ring in cylinder bore, and remove piston sealing ring. Repeat operation for remaining piston. **NOTE** — *DO NOT separate caliper halves.*

**Cleaning & Inspection** — Clean pistons and cylinder bores in alcohol or brake fluid. **CAUTION** — *DO NOT use mineral based solvents.* Check all parts for wear, scoring, or other damage; replace parts as necessary.

**Reassembly** — Install piston seal and sealing bellows into caliper bore. Lubricate piston with brake fluid and install through sealing bellows (crown first). Install inner edge of bellows in piston skirt, push piston to bottom of cylinder, and install snap ring. Repeat operation for remaining piston.

### REAR WHEEL CYLINDER

**Disassembly** — Remove dust boots and slide out piston assemblies. Remove seal from piston and spring from cylinder bore. Remove bleeder screw.

**Cleaning & Inspection** — Ensure pistons and cylinder are free of dirt, burrs and scratches. Thoroughly clean and dry all parts with a lint free cloth. Replace parts as necessary.

**Reassembly** — Install bleeder screw and tighten to specifications. Install new seals on pistons. Slide one piston into cylinder bore, then insert spring and remaining piston from opposite end and install dust boots.

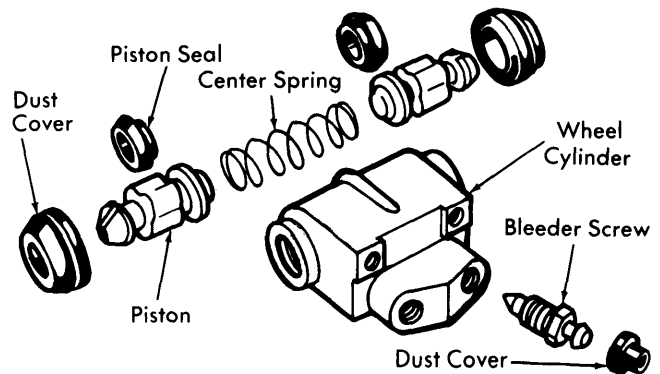

Fig. 5 Expanded View of Rear Wheel Cylinder Assembly

### MASTER CYLINDER

**Disassembly** — Remove reservoir from body. Loosen stop screw and push piston inward; remove snap ring. From primary chamber remove stop washer and primary piston assembly. With compressed air, force secondary piston assembly from its chamber.

**Cleaning & Inspecting** — While apart clean master cylinder and inner components with alcohol. Thoroughly dry all parts before reassembly.

**Reassembly** — Install secondary piston and replacement parts together in secondary chamber. Press piston inward and install stop screw. Release piston and let it contact stop screw. **NOTE** — *Length of stop screw must not change with new seal.* Reassemble primary piston and insert it into chamber. Position stop screw. **NOTE** — *Prevent burrs on secondary piston face by filling chambers with fluid before moving piston.* Install reservoir.

# Brakes

## CAPRI (Cont.)

### PRESSURE DIFFERENTIAL VALVE

**Disassembly** – Unscrew and remove warning switch. Remove retaining bolt, then using a small screwdriver, gently push piston assembly out of valve bore. Remove two rubber seals from piston and slide off sleeves.

**Cleaning & Inspection** – Thoroughly clean all parts and dry with a lint free cloth. Inspect all parts for wear or damage and replace as necessary. Inspect retaining clips on piston for wear and tightness and replace if necessary.

**Reassembly** – Slide sleeves on piston and install new rubber seals. Slide piston assembly into cylinder, then install retaining bolt. Install warning switch.

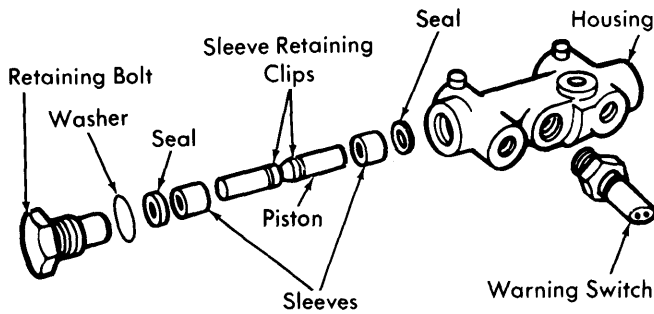

Fig. 6 Pressure Differential Valve Components

### TIGHTENING SPECIFICATIONS

Application	Ft. Lbs. (mkg)
Caliper Mounting Bolts .....	45-50 (6.2-6.9)
Rotor-to-Hub Bolts .....	30-34 (4.2-4.7)
Rear Backing Plate Bolts .....	15-18 (2.1-2.5)
Hydraulic Line Union Nuts.....	5-7 (.7-1.0)
Bleeder Screws.....	5-7 (.7-1.0)

### BRAKE SYSTEM SPECIFICATIONS

Application	Drum Diam. In. (mm)	Wheel Cylinder Diameter		Master Cylinder Diameter In. (mm)
		Front In. (mm)	Rear In. (mm)	
Capri II	9 (229)	2.125 ① (53.9)	.70 (17.8)	.....

① – Caliper bore diameter.

### DISC BRAKE ROTOR SPECIFICATIONS

Application	Disc Diameter In. (mm)	Lateral Runout In. (mm)	Parallelism In. (mm)	Original Thickness In. (mm)	Minimum Refinish Thickness In. (mm)	Discard Thickness In. (mm)
Capri II	9.625 (244.4)	.0035 (.089)	.0004 (.010)	.500 (12.7)	.460 (11.6)	.450 (11.3)