

SAAB POWER-ASSISTED RACK & PINION

99

DESCRIPTION

Power steering is added to some vehicles as optional equipment. The assembly consists of a rack and pinion steering gear with a servo valve which regulates the oil flow to a servo plunger on the rack. The hydraulic pressure is generated by an oil pump which is driven by a belt attached to the crankshaft pulley. A separate oil reservoir located by the right wheel housing supplies the system with hydraulic oil. The steering gear is permanently lubricated with oil. A tube running between the two ends of the steering gear housing leads the oil past the hydraulic portion of the rack.

REMOVAL & INSTALLATION

Removal — 1) Raise and support front of vehicle. Remove front wheels. Detach tie rod end assemblies from the control arms, using a suitable tool (899540). Unscrew left tie rod end assembly from tie rod.

2) Turn steering wheel a full turn to the left. Remove left cover under the instrument panel and move up the rubber bellows to expose the universal joint. Remove column support bolt. Unscrew delivery hose from pump. Plug hose and pump hole. Remove return hose from tube. Plug hose and tube.

3) Disconnect the speedometer cable from the transmission. From the left side, remove two retaining screws from steering gear, and remove the intermediate piece. On the right side, remove the yoke and intermediate piece. Move steering gear down slightly so the clamp screw holding the universal joint to the steering gear can be removed. Withdraw the universal joint.

4) Move steering gear over to right far enough so that the left tie rod can be bent down through the body opening while twisting the valve housing backward. Take steering assembly out down and to the right.

Installation — Installation is a reversal of removal procedure; however, tie rod ends are to be connected after gear assembly has been fully installed. Adjust toe-in.

OVERHAUL

POWER STEERING GEAR

Disassembly — 1) Clean exterior of gear assembly thoroughly before beginning work. Back off lock nut and remove tie rod end assemblies. Loosen clamps and take off rubber bellows. Bend up lock plate between end piece and rack.

2) Clamp toothed end of rack in a vise. Unscrew lock nut for radial adjustment of rack and adjusting screw. Withdraw adjusting screw retaining plate, spring, "O" ring, and plunger. Remove tubes between the servo valve and the two sides of the servo cylinder.

3) Unscrew three lock nuts and detach valve housing and servo valve with pinion. Keep servo valve in a clean plastic bag. Remove locking screw for ring nut (see illustration). Clamp gear end of housing vertically in padded vise and remove the ring nut using a suitable spanner (899596).

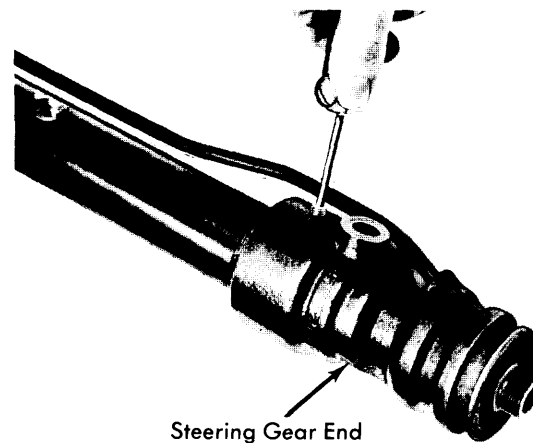

Fig. 1 Removing Ring Nut Locking Screw from Steering Gear End

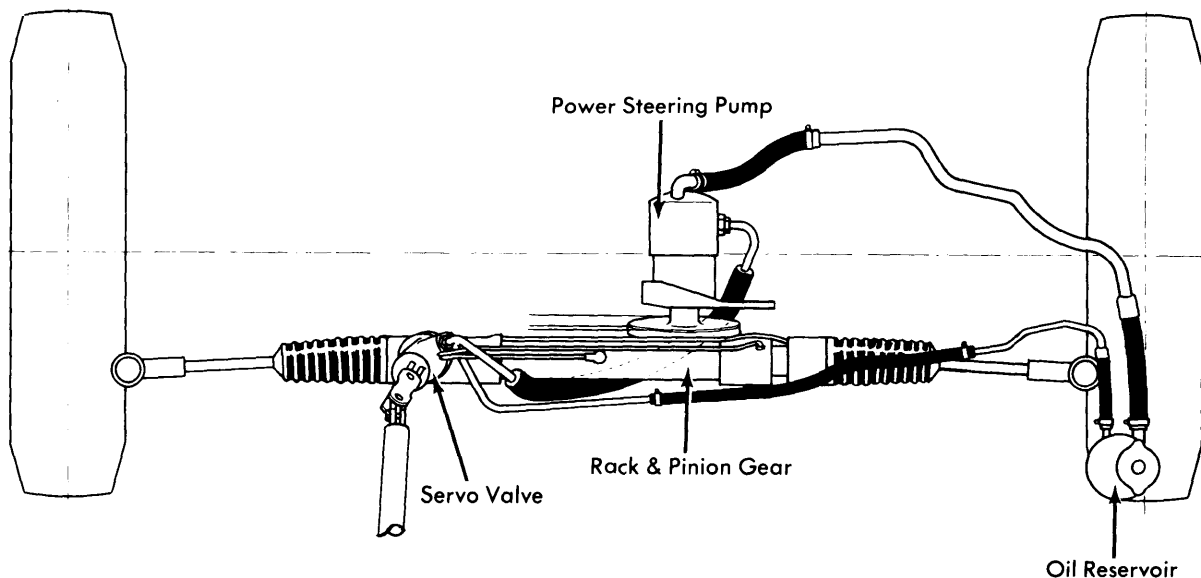

Fig. 2 Assembled View of Saab Power Steering Gear Components

Power Steering

SAAB POWER-ASSISTED RACK & PINION (Cont.)

4) Remove steering gear end from the cylinder and the rack while removing the bleeder tube. Set aside loose cone in hole for oil tube. Remove sealing ring, washer, and servo seal from steering gear end. Pull rack out of steering gear housing. Remove knurled sleeve, servo seal, and washer from cylinder. Remove plunger seal and snap ring. **NOTE** — *Plunger cannot be detached from rack.*

Assembly — 1) Apply Loctite to needle bearing seat and push in the needle bearing, if it has been removed. Fit snap ring and new teflon ring onto rack plunger. Slide knurled sleeve onto rack. Fit servo seal on fitting sleeve using the special cone tools (899593 and 899594). Slide sleeve with seal past teeth on rack. Remove tools. Turn notch in seal toward servo plunger.

2) Push rack into servo cylinder until knurled sleeve can be seen in hole for tube connection. Use a screwdriver to turn sleeve to expose its threaded hole. Screw in connecting screw temporarily to hold the washer in place. **NOTE** — *Do not tighten screw completely, or rack will be damaged.*

3) Insert servo seal into its seat. Turn notch in seal toward servo plunger. Slip on the washer. Turn smaller diameter of washer toward the servo seal. Fit flat sided seal. Put cone into tube connection hole and lock cone using special screw (899595). Cylindrical part of cone (inside steering gear end) serves to fix position of gear end in relation to servo cylinder. Screw fitting cone (899598) onto rack end and position steering gear end onto rack and servo cylinder while inserting the vent tube. Cylindrical portion of cone fits into "U" shaped recess in end of servo cylinder. Tighten ring nut with suitable wrench. Lock the nut with socket head screw.

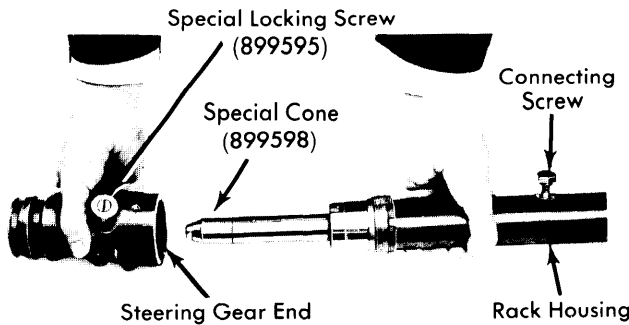

Fig. 3 Fitting Steering Gear End to Rack Housing

4) Install washer and seal between pinion and servo valve in gear housing. Position servo valve in housing. Position gasket between valve housing and gear housing. Insert sealing ring,

plastic washer, and lock ring in valve housing. Place installation tool (899597) over shaft end of valve. Attach valve housing.

5) Remove special locking screw (899595) from connection hole in steering gear end. Install tubes between servo valve and two sides of cylinder. Position new gaskets on banjo connection of the shorter tube to the cylinder. Install rack plunger, "O" ring, spring, cover, adjusting screw, and lock nut for radial adjustment of rack.

6) Clamp toothed end of rack in a padded vise, and install complete end pieces with thrust washer, spring, and lock washer. Lock the washer.

7) Adjust the radial play of the rack as follows: Screw in adjusting screw until resistance of the gear is felt. Back off screw 1/6 turn. Check that steering gear can be turned from lock to lock without jamming. Tighten adjusting screw lock nut.

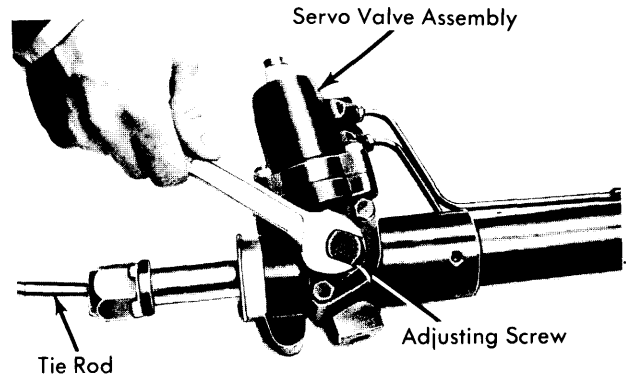

Fig. 4 Adjusting Rack Radial Play

8) Position rubber bellows and install (tighten) all clamps except one outer one. Hold steering gear vertically, with unclamped end up, and inject 6.5 fl. oz. of suitable EP 90 gear oil into the bellows. Attach remaining clamp. Install lock nuts and tie rod end assemblies.

TIGHTENING SPECIFICATIONS

Application	Ft. Lbs. (mkg)
Gear End Ring Nut	130-153 (16.5-17.5)
Valve Housing Lock Nuts	16.6 (2.3)
End Pieces (Inner Ball Joints)	47-54 (6.5-7.5)
Adjusting Screw Lock Nut	50-60 (7-8)