

BMW WORM & SECTOR

2002
3.0
530i

DESCRIPTION

STEERING GEARS

Steering gear is the worm and sector type. Worm gear is supported at each end by ball bearings and end play is controlled by shims between housing and cover. Sector shaft rotates in three needle roller bearings (two in gear housing, one in cover), and the two toothed sector shaft roller is meshed with worm gear. Sector shaft adjustment is controlled by adjustment screw in sector shaft cover.

STEERING LINKAGE

Linkage consists of a pitman arm, idler arm assembly, center link, and two tie rods. Outer ends of center link are connected to pitman arm and idler arm. Two adjustable tie rods connect inner ends of center link to steering arms located at the base of each suspension unit.

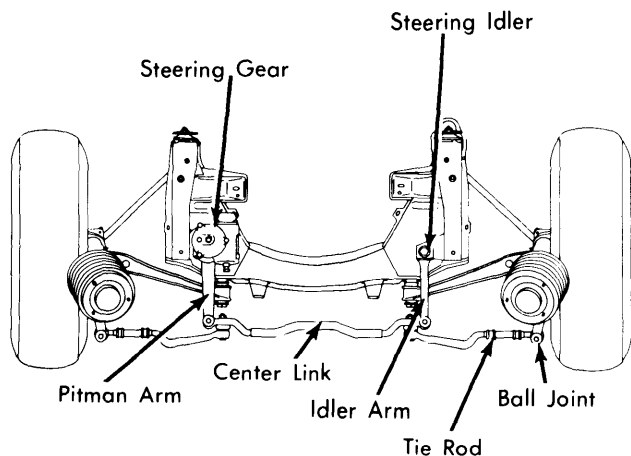

Fig. 1 Top View of BMW Steering Linkage

ADJUSTMENT

STEERING SHAFT

Steering gear assembly should be removed to adjust steering shaft. For adjustment procedure, see *Overhaul* in this article.

SECTOR SHAFT

Adjustment (In Vehicle) – 1) Disconnect steering linkage from pitman arm. Remove steering wheel center (cover). Count number of turns required to turn steering wheel from lock to lock, then turn wheel back half way to center steering gear.

Turn steering wheel about one turn to left. With a suitable torque wrench attached to steering wheel nut, turn wheel to right through the straight-ahead position and observe torque reading at this point. Torque required should be 6.9-10.4 INCH lbs. (8-12 cmkg).

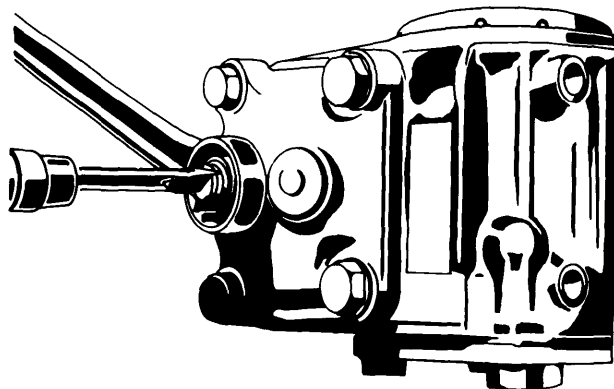

Fig. 2 Making the Sector Shaft Adjustment

2) To adjust, turn steering wheel about one turn to left. **NOTE** – In this position, worm cannot be pressed into its bearing at one end by the sector shaft roller, which may create the impression that no play is present. Loosen lock nut and turn adjusting screw until correct torque is obtained when steering wheel passes through the straight-ahead position. Tighten lock nut and recheck adjustment.

LUBRICATION

Steering Linkage – Ball joints are pre-lubricated and no routine maintenance is required.

Steering Gear Capacity – .63 pint for 2002 models and .93 pint for 3.0 and 530i models.

Gear Lubricant Type – S.A.E. EP 90.

REMOVAL & INSTALLATION

Removal, 2002 – Mark flexible coupling and steering gear shaft for reassembly reference. Loosen upper clamp bolt at coupling and remove lower bolt. Push coupling upward as far as possible. Disconnect steering linkage from pitman arm. Separate steering gear from front axle carrier and remove downward.

BMW WORM & SECTOR (Cont.)

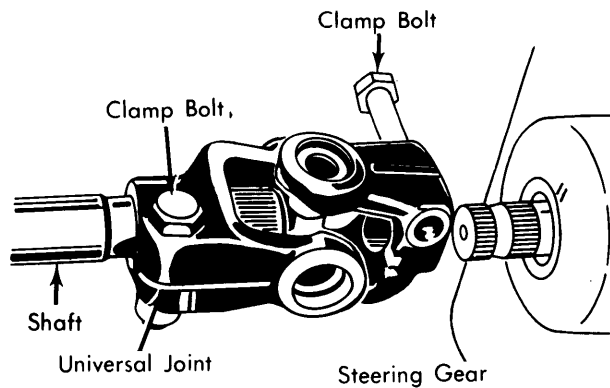

Fig. 3 2002 Lower Universal Joint Coupling at Worm Shaft

Removal, All Others — Mark universal joint and steering gear shaft for reassembly reference. Loosen upper clamp bolt at universal joint and remove lower bolt. Push universal joint upward as far as possible. Disconnect steering linkage from pitman arm. Separate steering gear from front axle beam and remove downward.

Installation — To install, reverse removal procedure.

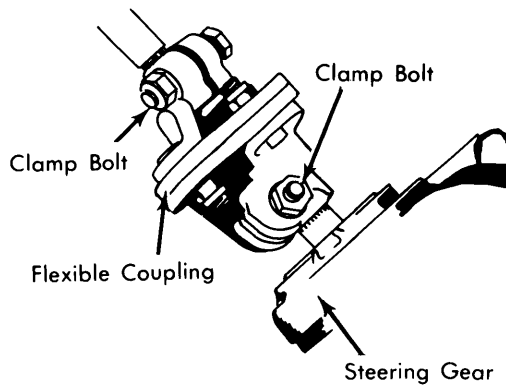

Fig. 4 3.0 and 530i Lower Flexible Coupling

OVERHAUL

Disassembly — Mark pitman arm and sector shaft for reassembly reference then, using a suitable puller, remove pitman arm. Remove cover with sector shaft. Remove end cover with shim pack, then drive worm shaft from housing with a plastic hammer. Remove oil seals from housing. Remove lock nut, then remove adjusting screw and sector shaft from cover.

Inspection — Clean all parts in a suitable solvent and blow dry with air. Inspection all parts for wear or damage and replace as necessary. **CAUTION** — When replacing sector

shaft bearings in housing, measure exact location of each bearing in bore before removal so that new bearings may be positioned correctly in bore. Install new oil seals in housing. Coat all through-bolts with a sealant before installation.

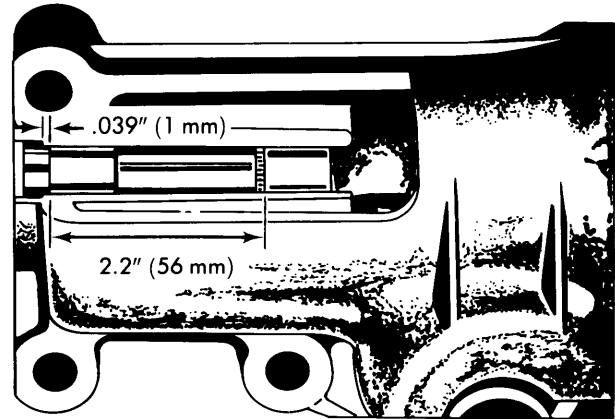

Fig. 5 Sector Shaft Bearing Location in Housing

Assembly — 1) Install steering worm, shim pack, and end cover. Install suitable torque wrench and rotate shaft while tightening end cover. Torque required to turn shaft should be .87-2.17 INCH lbs. (1.0-2.5 cmkg). Add or remove shims as required to obtain correct adjustment.

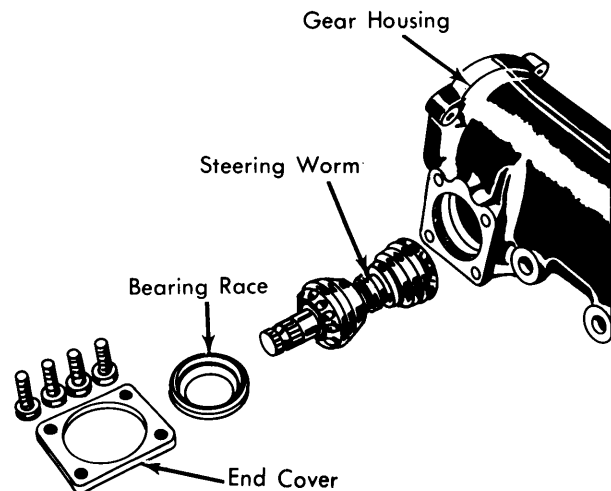

Fig. 6 Steering Worm Shaft and Related Components

2) Head of sector shaft adjusting screw is held in shaft by a washer and snap ring. End play between adjusting screw and sector shaft is controlled by thickness of washer. End play should be .002" (.05 mm). Replace washer if necessary with one of correct thickness to obtain desired end play.

Steering Gears & Linkage

BMW WORM & SECTOR (Cont.)

3) Install sector shaft and adjusting screw into housing cover, then install shaft into gear housing and tighten cover. Determine center position of sector shaft travel. Turn shaft to left, install a suitable torque wrench, then turn shaft to right and observe torque reading at center position. Torque required should be 6.9-10.4 INCH lbs. (8-12 cmkg). Turn adjusting screw until correct torque is obtained when sector shaft passes through center position. Tighten lock nut and recheck adjustment.

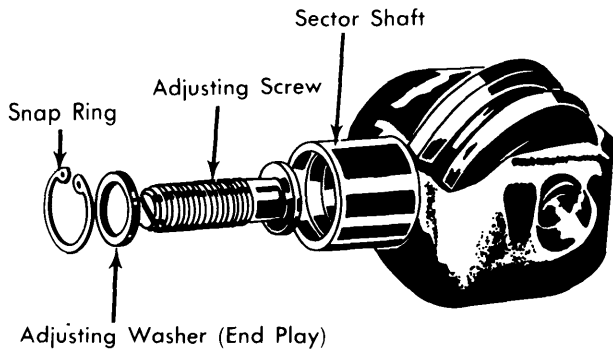

Fig. 7 Sector Shaft Adjustment Screw and Mounting Parts

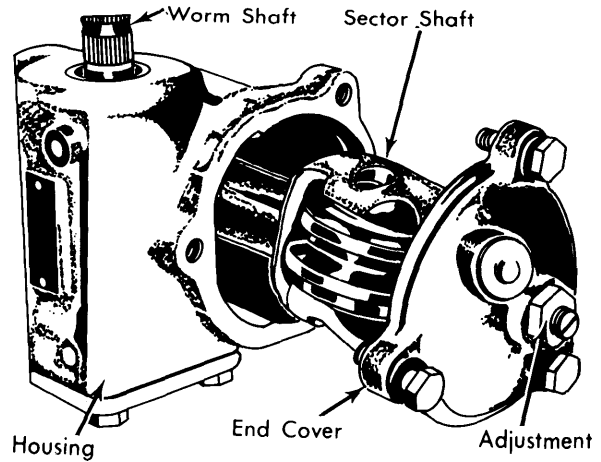

Fig. 8 Inserting Sector Shaft into Steering Gear Housing

TIGHTENING SPECIFICATIONS

Application	Ft. Lbs. (mkg)
Flexible Coupling Clamp	18-20 (2.49-2.77)
Universal Joint Clamp	18-20 (2.49-2.77)
Tie Rod Ball Joint	25-29 (3.46-4.01)
Center Link Ball Joint	25-29 (3.46-4.01)
Gearing Housing-to-Frame	31-35 (4.29-4.84)
Pitman Arm Nut	87-101 (12.03-13.97)