

TOYOTA COROLLA

Corolla

DESCRIPTION

Vehicles incorporate an energy absorbing steering column. The steering column is connected directly to the steering gear, having the steering worm as an integral part of the shaft. The column collapses on impact by shearing pin inserts. An expanded metal section of the column housing is also incorporated to assist in absorbing impact energy.

REMOVAL & INSTALLATION

STEERING COLUMN

Removal — 1) Working from inside engine compartment, remove bolt mounting steering mainshaft to steering gear box (Fig. 1). Before separating units, index mark for reinstallation and place front wheels in straight-ahead position.

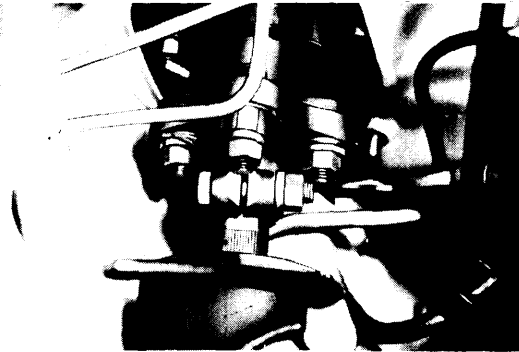

Fig. 1 Pinch Bolt Mounting Mainshaft to Steering Gear

2) Remove steering wheel and turn signal switch. See *Steering Wheel and Column Switch* in **STEERING** Section. From inside passenger compartment, remove bolts mounting hole cover to firewall. Remove nuts and bolts mounting the break-away bracket (Fig. 2) then withdraw steering column assembly into passenger compartment and free from vehicle.

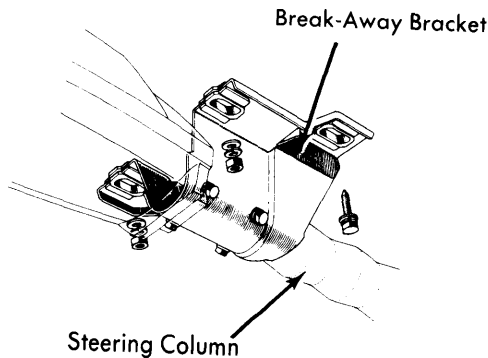
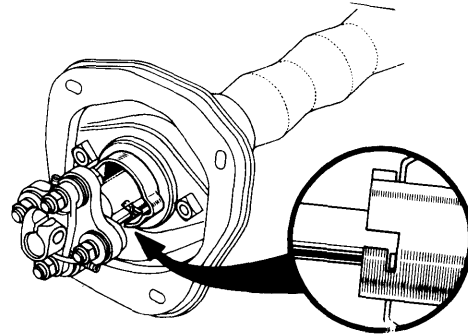

Fig. 2 Relative Position of Break-Away Bracket and Hardware

Installation — Working from inside passenger compartment, insert steering column assembly through column hole in firewall. Align index marks made during removal and tighten pinch bolt. Fit break-away bracket, but leave bolts finger tight. Position column hole cover in place with a new "O" ring seal. Push in column tube until fully seated, then tighten nuts mounting break-away bracket. Make sure hole cover locating pin contacts cover as shown in Fig. 3.



Locating Pin Making Proper Contact with Hole in Cover

Fig. 3 Proper Installation of Steering Column

OVERHAUL

STEERING COLUMN

Disassembly — Remove upper steering column bracket. From column tube, pull out mainshaft, then remove dust seal. From lower end of mainshaft, remove flexible coupling unit. Remove bolts attaching column plate, rotate column tube counterclockwise and remove it from column hole cover.

Inspection — Check mainshaft for out-of-alignment and looseness in plastic pin. Inspect column tube for deformation. Look closely at flexible coupling for deterioration, also check dust seal "O" ring for damage.

Reassembly — To reassemble components, reverse disassembly procedure and note the following: Apply a light coat of grease to both sides of "O" ring.

TIGHTENING SPECIFICATIONS

Application	Ft. Lbs. (mkg)
Steering Gear-to-Frame	22-33 (3.04-4.56)
Pitman Arm-to-Sector Shaft	58-87 (8.02-12.0)
Column Tube Clamp	22-33 (3.04-4.56)
Steering Wheel Nut	14-22 (1.94-3.04)