

DATSUN 280Z

280Z

DESCRIPTION

The steering column assembly used on the 280Z is a safety, collapsible type. A rubber coupling is used to prevent road vibrations from reaching the steering wheel. Two universal joints are incorporated between the steering gear and steering wheel to give the most suitable steering wheel position and angle. The column is a steel ball type which is designed to compress on impact, absorbing the collision shock.

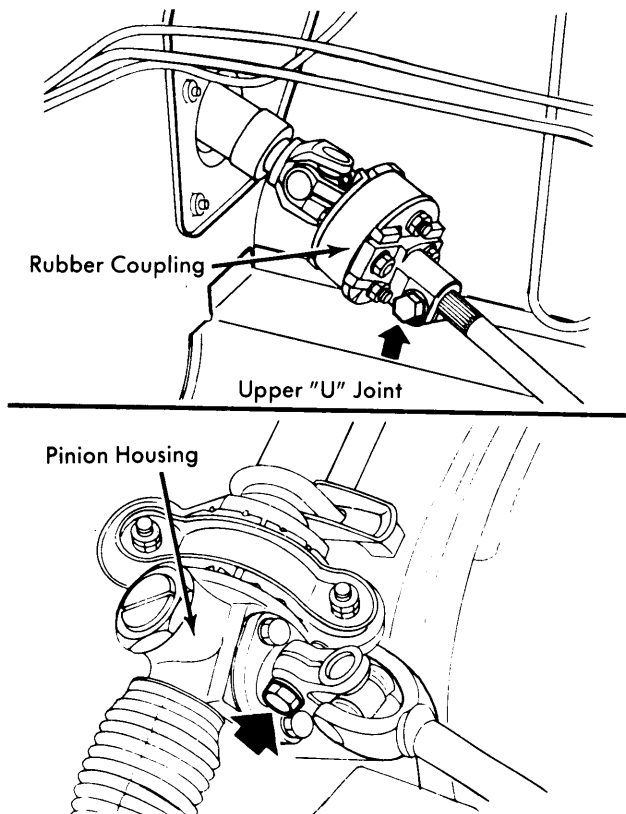

Fig. 1 Details of Steering Column Universal Joints & Couplings

Inspection — Check for smoothness of rotation at all steering components. Inspect jacket tube for deformation or breakage (replace if necessary). Check column shaft spring for proper tension: free length, 1.075" (27.3 mm); loaded length, .059" @ 66 lbs. (15 mm @ 30 kg). Measure distance from upper end of tube collapsible section to lower side of column support clamp. If this measurement is less than 6.933" (176.1 mm), collapsing of column has occurred and column should be replaced. Also inspect inserts in column support clamp. If they protrude beyond the clamp, damage to column may be suspected.

Installation — Install lower joint section after installation of steering column. Set front wheels in straight-ahead position, line up slits of universal joints with punch mark on upper end of steering shaft (punch mark should be on top), then connect column and tighten bolts as required. After installation, ensure steering wheel rotates smoothly.

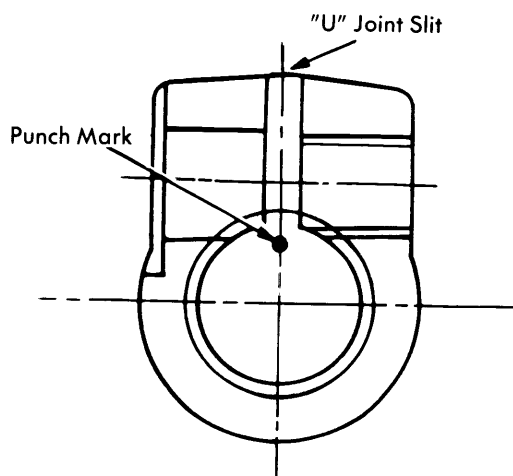

Fig. 2 Detail Showing Punch Mark Alignment

STEERING COLUMN UNIVERSAL JOINTS & COUPLING

REMOVAL & INSTALLATION

NOTE — During any service procedure involving the steering assembly, do not hammer or exert extreme pressure on the steering column or damage to the collapsible section may result.

Removal — Disconnect column assembly from lower joint shaft at rubber coupling (remove clamp bolt). Remove steering wheel. See *Datsun under STEERING WHEEL & COLUMN SWITCHES* in this section. Detach column shroud halves and remove lighting switch assembly. Unscrew bolts retaining column tube flange plate to toeboard. Support steering column at upper end and remove column clamp bolts. Draw out steering column assembly from passenger compartment side. Loosen clamp bolt at pinion shaft and remove lower steering joint section.

OVERHAUL

NOTE — Refer to *Inspection* in this article for description of components which may be replaced; however, if damage to the collapsible section is suspected, steering column replacement is recommended.

TIGHTENING SPECIFICATIONS

Application	Ft. Lbs. (mkg)
Steering Wheel Nut	36-51 (5.0-7.0)
Column Clamp Bolt	6-8 (0.8-1.1)
Jacket Tube Bracket Bolt	4-5 (.54-.74)
Rubber Coupling Securing Bolt	12-14 (1.7-2.0)
Lower Joint-to-Rubber Coupling	17-20 (2.3-2.7)
Lower Joint-to-Pinion Shaft	29-36 (4.0-5.0)