

10-4 Steering Wheel & Column Switches

BMW (Cont.)

STEERING LOCK AND IGNITION SWITCH

Removal (4 Cylinder Models) – Remove steering column. See *Steering Columns In STEERING Section*. Disconnect battery ground strap. Remove outer tube casing. Chisel out shear bolts. Remove flat head retaining screw and pull out steering lock from steering column.

Installation – To install, reverse removal procedure and note the following. Ensure retaining screw properly engages locating hole in outer tube. Tighten shear bolts evenly.

Removal (6 Cylinder Models) – 1) Remove battery ground strap. Remove steering wheel as previously outlined. Remove steering column lower casing. Disconnect and remove turn signal wiper/washer switches at the switch plate.

2) Chisel off switch plate shear screws. Remove ignition lock screw and pull out ignition switch. Chisel off steering lock plate shear bolt, remove lock plate, and pull out steering lock.

Installation – To install, reverse removal procedure and note the following: Place steering in straight ahead position. Centralize turn signal indicator plate. Tighten all nuts and bolts evenly.

CAPRI

Capri

STEERING WHEEL

Removal – Align wheels in straight-ahead position. Remove two screws securing steering column shroud and detach both halves. Pry out steering wheel center emblem. Unscrew steering wheel nut. Note alignment marks on wheel and shaft. Pull off steering wheel, using hand pressure only.

Installation – To install, reverse removal procedure, noting the following: Realign positioning marks of steering wheel and shaft. Ensure turn signal cancelling cam is engaged in groove on underside of steering wheel.

TURN SIGNAL & IGNITION SWITCHES

Removal – Disconnect battery. Remove steering column shroud upper and lower halves. Remove turn signal switch retaining screws, disconnect electrical plug and remove turn signal switch. Place ignition key in the "O" position, then remove screws from the lower left trim panel. Disconnect electrical plug from emergency flasher then remove trim panel.

Disconnect ignition wires at connector then remove screws securing ignition switch to lock and remove ignition switch.

Installation – To install, reverse removal procedure, making sure that ignition key is in the "O" position and all wires are reconnected.

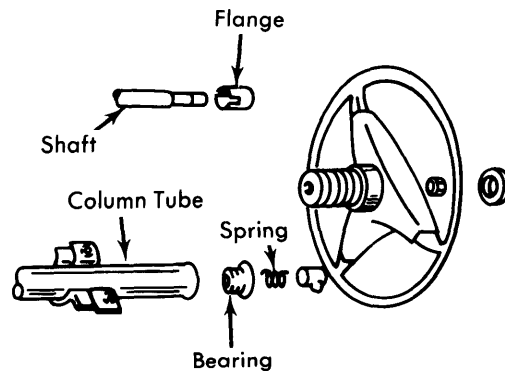

Fig. 1 Capri Steering Wheel Components

COLT

Colt

HORN BUTTON & STEERING WHEEL

Pry off horn pad. Mark relative position of steering wheel on the shaft for reassembly reference. Remove steering wheel nut, then use a suitable puller (CT-1126 with standard steering wheel; DT-1001 with sports type steering wheel) to detach the wheel. **CAUTION** – Do not use force to remove the wheel.

COMBINATION SWITCH

To remove the combination turn signal, wiper/washer, dimmer, and hazard warning switch assembly, proceed as follows: Remove steering wheel as outlined, then tilt steering wheel to its lowest position. Remove the combination switch and column cover. Disconnect wiring from the column switch and withdraw the column switch assembly.

COURIER

Courier

STEERING WHEEL, HORN BUTTON, TURN SIGNAL SWITCH

Disconnect battery ground cable. Remove horn button by turning counterclockwise. Remove contact spring. Mark relative position of steering wheel to shaft. Remove steering wheel nut, then pull wheel from shaft. Remove cancelling cam and snap ring. Disconnect combination turn signal/dimmer switch wires. To install, reverse removal procedure.

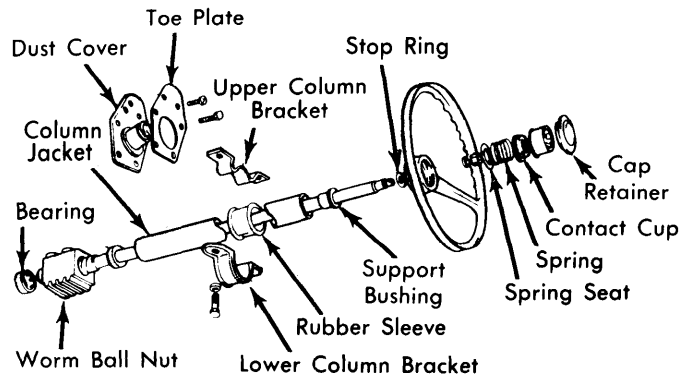

Fig. 1 Courier Steering Wheel and Column