

Rear Suspension

VOLKSWAGEN TYPE 1

Type 1
Sedan
Super Beetle
Karmann Ghia
"The Thing"

DESCRIPTION

Independent torsion bar type rear suspension. Torsion bars are mounted inside rear crossmember tube and anchor in center by means of a splined hub. Outer ends of torsion bars mount into splined hubs integral with spring plates which connect at ends to control arms. Control arms pivot in mounts connected to crossmember tube and also serve as rear wheel bearing carriers. Hydraulic shock absorbers mount between control arms and mount integral with rear crossmember tube.

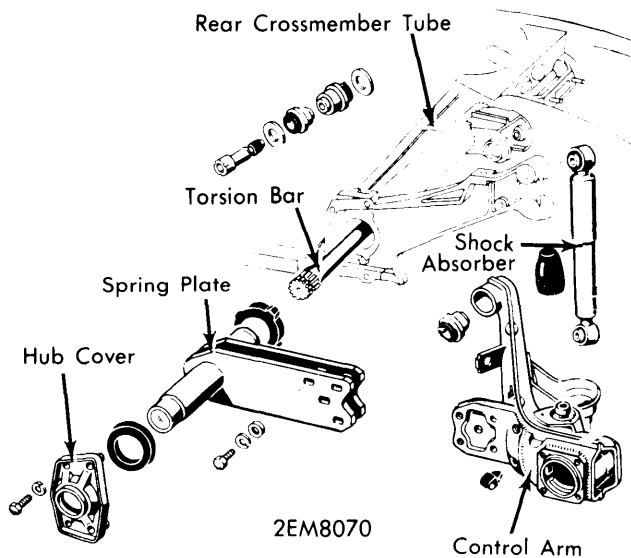

VOLKSWAGEN TYPE 1 REAR SUSPENSION

ADJUSTMENT

WHEEL ALIGNMENT SPECIFICATIONS & PROCEDURES — See Volkswagen Rear Wheel Alignment Specifications and Procedures in WHEEL ALIGNMENT Section.

REMOVAL & INSTALLATION

CONTROL ARMS

Removal — Remove cotter pin and loosen rear hub nut. Raise vehicle and place safety stands under body. Remove wheel and tire. Remove bolts securing outside axle shaft joint to flange and separate axle shaft from flange. Protect joint on

axle shaft by covering with a suitable protective cap. Remove axle shaft nut and remove brake system components from rear wheel hub. **NOTE** — See appropriate story in BRAKE SYSTEMS Section for removal. Mark location of spring plate in relation with control arm and remove bolts and nuts securing spring plate to control arm. Remove control arm pivot bolt and remove control arm from vehicle. Note location of adjusting washers when removing control arm from mount for installation.

Installation — Reverse removal procedure for installation. Tighten pivot bolt and lock in place by staking edge to metal shoulder on bracket. Ensure spring plate marks align with marks on control arm. Bleed brake system.

TORSION BARS & SPRING PLATES

Removal — Disconnect control arm from spring plate as previously outlined (control arm does not need removal from vehicle for removal of spring plate and torsion bar). Remove bolts securing hub cover and remove cover. Pry spring plate off lower stop. On sedan models five bolts must be removed from front of rear fender to allow removal of spring plate and torsion bar. Remove spring plate and withdraw torsion bar. If torsion bar is broken, opposite side torsion bar must be removed to drive out broken piece.

Installation — Inspect torsion bar and spring plate for wear or distortion. Inspect rubber mounts for cracking or wear. Torsion bars are marked left and right and should be installed accordingly. Coat torsion bar splines with grease and install in vehicle. Coat rubber supports with talcum powder. Make sure part of rubber support marked "Oben" is up. Install spring plate in correct position. **NOTE** — See appropriate story in WHEEL ALIGNMENT Section for torsion bar setting procedure. Install hub cover and secure with two bolts. Raise spring plate with a suitable spring compressor (VW655/3) and install remaining hub cover bolts. To install remaining components, reverse removal procedure. Check rear wheel alignment.

TIGHTENING SPECIFICATIONS

Application	Ft. Lbs. (mkg)
Shock Absorber Upper and Lower Mounts.....	50 (6.9)
Control Arm Pivot Bolt.....	87 (12.0)
Spring Plate-to-Control Arm.....	72-87 (10.0-12.0)
Spring Plate Hub Cover Bolts.....	25 (3.5)
Axle Shaft-to-Flange Bolts.....	25 (3.5)
Rear Axle Hub Nut.....	253 (35.0)