

Rear Suspension

FIAT 128

128 Sedan
128 Station Wagon
128 Sport L

DESCRIPTION

Independent type rear suspension utilizing a transverse leaf spring. Wheel bearing carriers are supported by control arms connected to chassis and by hydraulic double action shock absorbers connected at top to inner fender panel. Transverse leaf spring is connected to chassis at center and to control arms at outside.

ADJUSTMENT

WHEEL ALIGNMENT SPECIFICATIONS & PROCEDURES

See *Wheel Alignment Specifications & Procedures* in **WHEEL ALIGNMENT** Section.

WHEEL BEARING ADJUSTMENT

See *Wheel Bearing Adjustment* in **WHEEL ALIGNMENT** Section.

REMOVAL & INSTALLATION

SHOCK ABSORBER & CONTROL ARM

Removal - 1) Raise rear of vehicle, position safety stands under chassis and remove rear wheels. Disconnect and plug brake flex line. Disconnect parking brake cable from lever on back of backing plate. Position a jack under control arm, raise slightly and disconnect upper shock absorber mount, accessible from inside luggage compartment.

2) Remove outer mount pad securing spring to control arm. Remove nuts securing control arm pivot shaft to chassis. Lower jack and remove shock absorber and control arm. Note number and position of wheel alignment shims between control arm pivot shaft and body mount for installation.

Installation - To install control arm and shock absorber, reverse removal procedure. Bleed brake hydraulic system. Tighten control arm pivot shaft nuts with weight of vehicle on rear wheels.

CONTROL ARM BUSHINGS

Removal - Remove shock absorber and control arm as previously outlined. Remove pivot bolt securing control arm to bearing carrier and shock absorber mount. Remove inner pivot shaft nuts at control arm. Using a press and a suitable mandrel (A. 47057), press out on pivot shaft until bushing is partially removed. This allows for removing tool to properly center on opposite bushing. Using same procedure, remove other bushing. Remove control arm from press and extract remaining bushing. Remove bearing carrier bushings in control arm with a suitable puller (A. 47057).

Installation - 1) Using same tools as used for removal in addition to a suitable spacer (A. 74220) installed between inner legs of control arm, press bushings into control arm onto pivot shaft. Use same tool as used for removal to reinstall bearing carrier bushings into control arm.

2) When reconnecting control arm to bearing carrier, the correct shim thickness between control arm and shock absorber mount must be determined. See *Control Arm Shim Determination*. Reinstall control arm, bearing carrier and shock absorber as previously outlined. Tighten control arm to bearing carrier pivot bolt with weight of vehicle on rear wheels.

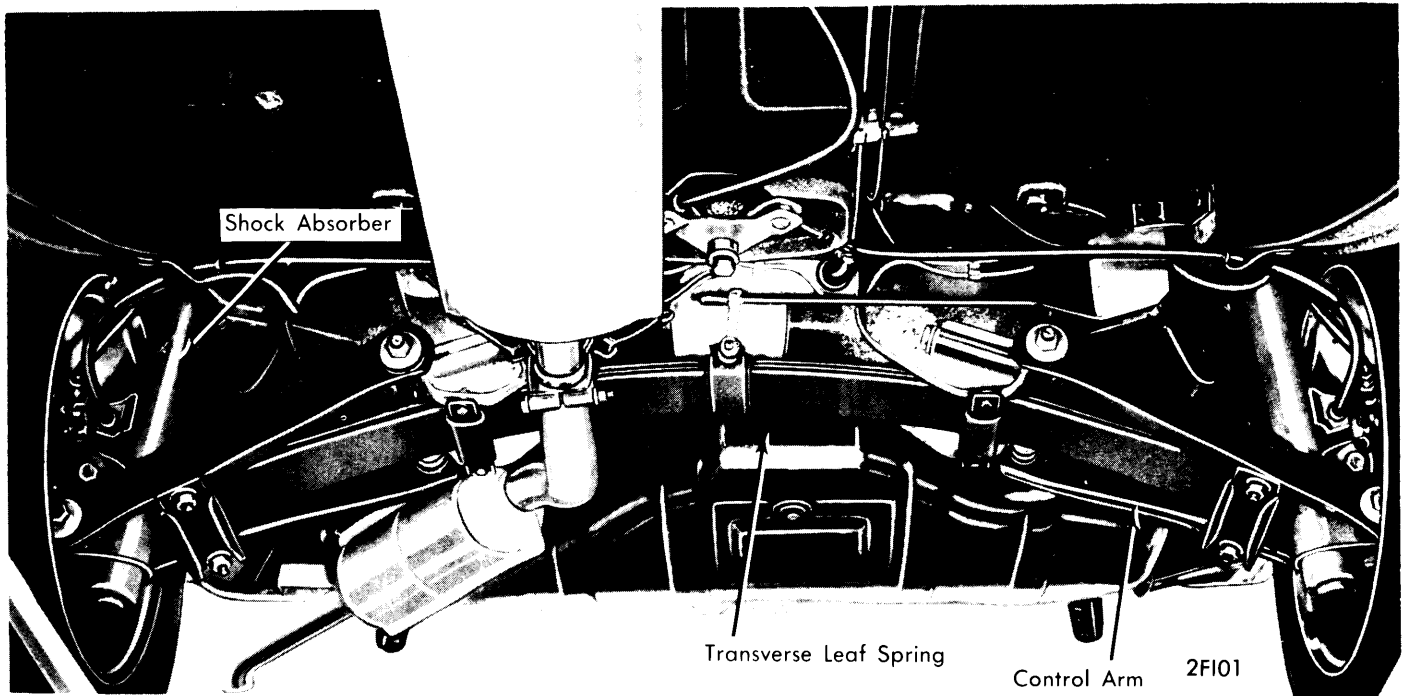

REAR SUSPENSION COMPONENTS

FIAT 128 (Cont.)

CONTROL ARM SHIM DETERMINATION

Measure distance ("A" see illustration) between outer bushings on control arm. Measure width ("B" see illustration) of shock absorber mount. Add .118" to the difference of measurements "A" and "B". This will give the thickness required for both shims. The thickness of each shim must not vary more than .020".

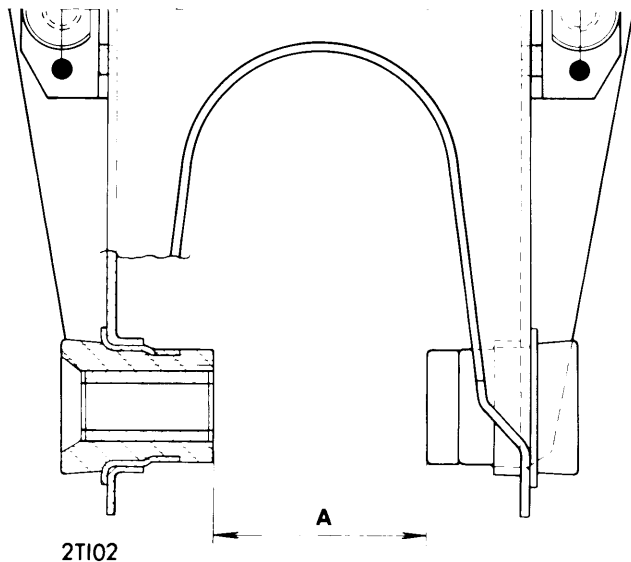

SHIM THICKNESS MEASURING POINT "A"

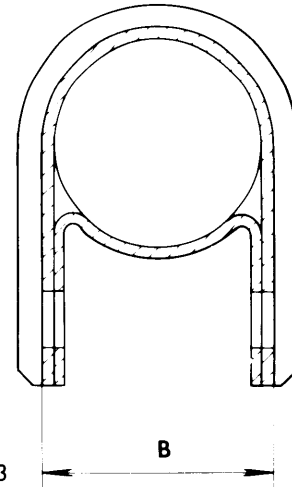

SHIM THICKNESS MEASURING POINT "B"

TRANSVERSE LEAF SPRING

Removal — Raise rear of vehicle, position on safety stands and remove wheels. Place a jack under left end of spring and raise enough to release spring from rubber mounting pad on control arm. Remove cotter pin and disconnect rod linking spring to brake regulator (if equipped). Remove mount for rubber pad on bottom of control arm and lower jack to release spring. Repeat same procedure for opposite side. Remove two guides securing spring to chassis and remove spring.

Installation — Inspect spring making sure there are not any cracked or broken leaves. Inspect all rubber mounts and inter leaf shims for wear or damage. To install transverse leaf spring, reverse removal procedure.

TIGHTENING SPECIFICATIONS

Application	Ft. Lbs. (mkg)
Rear Wheel Hub Nut.....	101 (14.0)
Leaf Spring Mounting Pad-to- Control Arm	22 (3.0)
Control Arm-to-Bearing Carrier Pivot Bolt	58 (8.0)
Control Arm-to-Chassis Pivot Bolt	36 (5.0)
Control Arm Pivot Shaft End Nuts	32 (4.4)
Upper Shock Absorber Mount	18 (2.5)
Lower Shock Absorber Mount.....	43 (6.0)
Brake Backing Plate Assembly-to- Bearing Carrier	18 (2.5)