

## VOLKSWAGEN TYPE 2

**Type 2**  
Transporter

### DESCRIPTION

Independent ball joint type suspension with torsion bars. Front axle beam consists of two horizontal tubes held together at ends by endplates welded to tubes. Torsion bars are mounted inside tubes and anchor in center. Torsion arms are connected to end of torsion bars and mount to steering knuckles by means of ball joints. Hydraulic shock absorbers are mounted between lower torsion arms at bottom and to axle beam endplates at top. A stabilizer bar is mounted to lower torsion arms. Complete front axle assembly is removable.

### ADJUSTMENT

#### WHEEL ALIGNMENT SPECIFICATIONS & PROCEDURES

See *Wheel Alignment Specifications & Procedures* in *WHEEL ALIGNMENT* Section.

#### WHEEL BEARING ADJUSTMENT

See *Wheel Bearing Adjustment* in *WHEEL ALIGNMENT* Section.

#### BALL JOINT CHECKING

See *Ball Joint Checking* in *WHEEL ALIGNMENT* Section.

### REMOVAL & INSTALLATION

#### FRONT AXLE ASSEMBLY

**Removal** — Most repairs to front axle components can be done with front axle assembly in vehicle, but complete assembly can be removed. Raise vehicle and place safety

stands under body. Remove wheel and tires. Disconnect brake lines from flex hoses at brackets and plug brake lines. Disconnect speedometer cable at left steering knuckle. Remove cover plate under pedal assembly and remove gear shift rod and lever. Disconnect clutch cable at pedal and hand brake cables at lever. Remove nut from drag link stud and press out of pitman arm. Remove steering damper bolt at bracket. Secure a suitable holding fixture to axle (VW610) and place a floor jack under fixture. Remove four bolts securing axle assembly to chassis, lower jack and remove axle assembly.

**Installation** — Reverse removal procedure for installation. Tighten all bolts and nuts to specifications. Bleed brake system and check wheel alignment.

#### STEERING KNUCKLE

**Removal** — Raise vehicle and place safety stands under body. Remove wheel and tire. If left side steering knuckle is being removed, pull out speedometer cable. Remove brake system components from steering knuckle. *NOTE* — See appropriate story in *BRAKE SYSTEMS* Section for removal. Remove nut from tie-rod end stud and separate tie-rod from steering knuckle with a puller. Remove nut from lower ball joint and separate ball joint from steering knuckle with a suitable removing tool (VW267A). Remove nut from upper ball joint and loosen eccentric bushing with a suitable wrench (VW179). Press ball joint from steering knuckle with eccentric bushing still on ball joint. Remove steering knuckle from vehicle.

**Installation** — Inspect steering knuckle for wear or distortion. Loosely attach steering knuckle to lower ball joint. Raise lower torsion arm using a suitable spring tensioner (VW655/3) until steering knuckle can be attached to upper ball joint. Notch on eccentric bushing must face front of vehicle. Install new self-locking nuts and tighten to specifications. Tighten tie-rod end

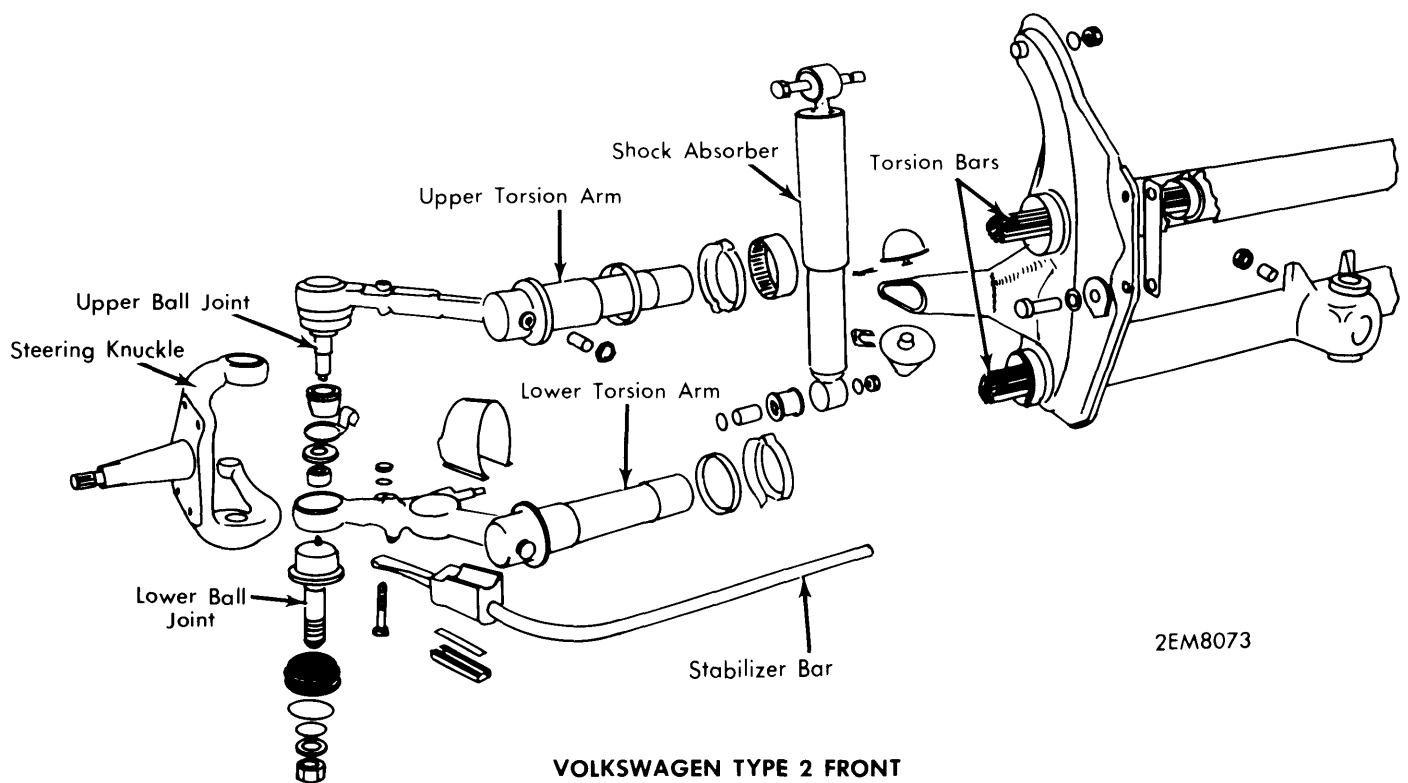

**VOLKSWAGEN TYPE 2 FRONT SUSPENSION**

# Front Suspension

## VOLKSWAGEN TYPE 2 (Cont.)

nuts to specifications and install cotter pin. Reverse removal procedure to install brake system components. Adjust front wheel bearings and wheel alignment. Bleed brake system.

### STABILIZER BAR

**Removal** — Knock retaining clip from clamp. Bend up clamp and remove plates. Remove nut from retaining bolt and remove bolt. Remove stabilizer bar from vehicle.

**Installation** — Inspect rubber components for wear or cracking. Inspect stabilizer bar for wear or distortion. Install stabilizer bar and retaining bolt and tighten nut to specification. Install clamp with cutout facing wheel. Press edges of clamp together with a pair of pliers and install clip. Make sure tongue edge of clip is facing axle beam. Lock clip by bending over tongue.

### TORSION ARMS & BALL JOINTS

**Removal** — Raise vehicle and place safety stands under body. Remove wheel and tire. Remove steering knuckle and stabilizer bar as previously outlined. Back lock-nuts from set screws and remove set screws. Pull torsion arms out of axle tubes. Press ball joints out of torsion arms with a press and suitable mandrels.

**Installation** — Press ball joints into torsion arms. When pressing ball joints into control arms make sure that notches in shoulder of ball joint align with forged projections on torsion arm. Install a suitable peening tool (VW471) on press and peen ball joint 3 times with a pressure of 6 tons to insure ball joint is properly seated in torsion arm. Thoroughly grease pivot portion of torsion arm and install in axle tube. Reverse removal procedure for installation of remaining components. Tighten all bolts and nuts to specifications. Bleed brake system and check wheel alignment.

### SHOCK ABSORBER MOUNTING STUD

**Removal** — Remove lower torsion arm as previously outlined. Drive dowel pin out and pull stud from torsion arm. If stud is broken, center punch in center of remaining piece and drill a .12" pilot hole in stud. Then drill remaining piece out with a .423" drill.

**Installation** — Replacement studs are oversized. Drill out hole with a .483" drill and ream to .4904" - .4914". A press fit of .0004" - .002" is required for proper fit. Press stud in arm until

distance between shoulder of arm and end of stud is 1.77" - 1.79". Drill through dowel pin hole with .157" - .161" drill and drive in dowel pin. Install torsion arm in vehicle as previously outlined.

### TORSION BARS, AXLE TUBE BUSHINGS & BEARINGS

**Removal** — Raise vehicle and place safety stands under body. Remove both wheels and tires. Remove steering knuckles from both sides as previously outlined. Remove torsion arm from one side of torsion bar. If lower bar is being removed, remove shock absorber. If upper bar is being removed, remove gear shift rod at coupling and set to one side. Loosen lock-nut and remove screw from center of axle tube. Pull out on remaining torsion arm and remove torsion bar. Remove torsion arm from bar. Measure inside diameter of bushing in axle tube, if more than 1.708", replace bushing. Remove bushing by pulling out bearing and then bushing with a suitable puller (VW771).

**Installation** — Thoroughly clean bearing and bushing seats in axle tube. Measure inside diameter of bearing seat. Standard and oversize bearings are used make sure correct bearing is used. Lubricate bearing seat and drive bearing in using a suitable punch (VW772). Drive bearing in approximately .276" from edge of axle tube. Drive bushing into axle tube using a suitable punch (VW772). Drive bushing into axle tube approximately 5.551" from edge of axle tube. Install seal retainers with lugs in vertical position. Reverse removal procedure for installation of remaining components. Thoroughly grease front axle assembly.

### TIGHTENING SPECIFICATIONS

Application	Ft. Lbs. (mkg)
Ball Joint Stud Nuts .....	72 (10.0)
Torsion Arm Set Screw .....	29 (4.0)
Torsion Arm Set Screw Lock Nut .....	29 (4.0)
Stabilizer Bar Retaining Nut .....	31 (4.3)
Shock Absorber	
Lower Mount Nut .....	36 (5.0)
Upper Mount Nut .....	36 (5.0)
Torsion Bar Set Screw .....	29 (4.0)
Torsion Bar Set Screw Lock Nut .....	29 (4.0)
Axle Assembly-to-Body .....	78 (10.8)
Tie Rod End Stud Nut .....	22 (3.0)