

Front Suspension

RENAULT

R-12
R-15
R-17

DESCRIPTION

Independent type front suspension with coil springs. Wheel is supported by steering knuckle mounted between upper and lower control arms by means of ball joints. Hydraulic double acting shock absorbers are mounted between upper control arm and chassis with coil spring mounted to upper portion of shock absorber. A strut rod is connected to chassis and upper control arm. A stabilizer bar is bolted to chassis and to ball joint of upper control arm link.

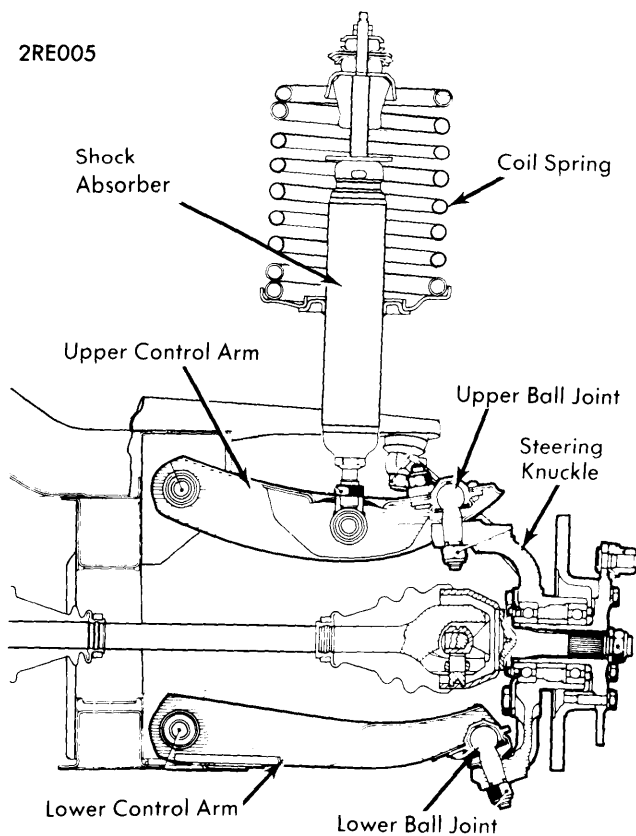

FRONT SUSPENSION ASSEMBLY

ADJUSTMENT

WHEEL ALIGNMENT SPECIFICATIONS & PROCEDURES

See *Wheel Alignment Specifications and Adjustments* in *WHEEL ALIGNMENT* Section.

WHEEL BEARINGS

See *Wheel Bearing Adjustment* in *WHEEL ALIGNMENT* Section.

BALL JOINT CHECKING

See *Ball Joint Checking* in *WHEEL ALIGNMENT* Section.

REMOVAL & INSTALLATION

FRONT SUSPENSION ASSEMBLY

Removal - Raise and support vehicle. Remove wheel and disconnect steering arm at rack end. Install spring compressor then disconnect top of shock absorber. Loosen lock nut at bottom of shock absorber and unscrew shock absorber until it can be removed with coil spring attached. Disconnect strut rod and stabilizer bar from upper control arm. Remove nuts and bolts securing upper control arm. Remove nuts and bolts securing lower control arm. Remove hub and brake assembly without disconnecting brake hose. Slowly pull suspension assembly from vehicle separating steering knuckle from axle. **NOTE** - Do not pull from gear box.

Installation - Coat axle splines with Molykote and reverse removal procedure. Tighten all nuts and bolts.

UPPER CONTROL ARM & BALL JOINTS

Removal - Raise and support vehicle. Remove wheel and disconnect strut rod and stabilizer bar from upper control arm. Using suitable tool (T.Av 476), remove steering arm ball joint and steering knuckle ball joint. Remove nut securing upper control arm pivot shaft and remove pivot shaft. Disconnect shock absorber from upper control arm and remove control arm.

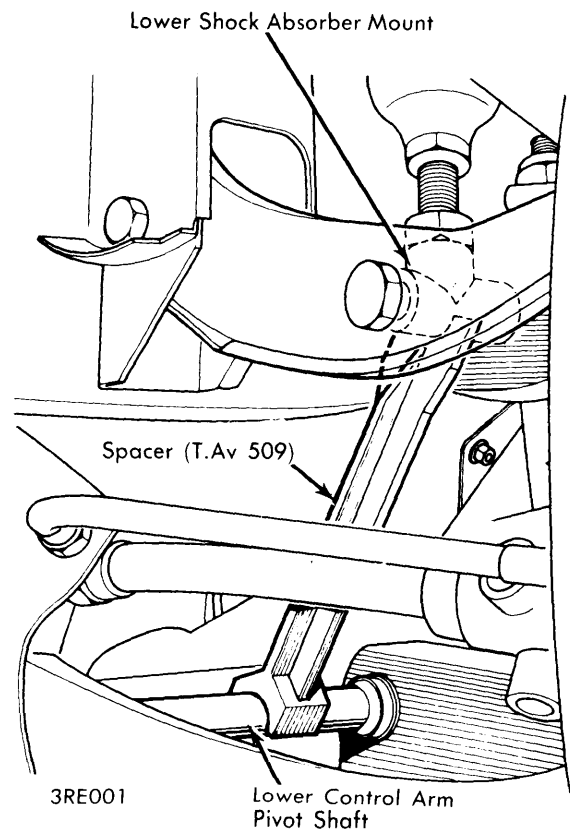

SPACER TOOL INSTALLATION

RENAULT (Cont.)

Installation – To install, reverse removal procedure. Coat control arm pivot shaft with suitable grease and tighten all nuts and bolts.

LOWER CONTROL ARM & BALL JOINT

Removal – Raise and support vehicle and remove wheel. Using a suitable tool (T.Av 476), disconnect lower control arm ball joint. Disconnect and remove lower control arm pivot shaft and remove lower control arm.

Installation – To install, reverse removal procedure. Coat control arm pivot shaft with suitable grease and tighten all nuts and bolts.

UPPER & LOWER BALL JOINTS

Removal – Using a suitable tool (T.Av 476) disconnect ball joint, then drill out rivets securing ball joint and remove ball joint.

Installation – To install, reverse removal procedure, replacing rivets with nuts and bolts. *NOTE* – Place bolt head on same side as dust cover.

STEERING KNUCKLE

Removal – Raise and support vehicle then remove wheel. Place spacer between lower shock absorber mount and lower control arm pivot shaft. Remove hub and brake assembly without disconnecting brake hose. Separate three ball joints using suitable tool (T.Av 476). After disconnecting ball joints, remove steering knuckle. *NOTE* – Do not pull axle from gear box.

Installation – Coat axle splines with Molykote and reverse removal procedure. Tighten all nuts and bolts.

TIGHTENING SPECIFICATIONS

Application	Ft. Lbs. (mkg)
Upper Control Arm-to-Chassis	75 (10.4)
Lower Control Arm-to-Chassis	80 (11.1)
Steering Arm Ball Joint	25 (3.4)
Lower Ball Joint	35 (4.8)
Upper Ball Joint	35 (4.8)
Shock Absorber Lower Lock Nut	45 (6.2)