

DATSUN 620

Datsun 620

DESCRIPTION

Independent type suspension with torsion bars. Upper and lower control arms pivot on brackets which are integral with chassis. A steering knuckle spindle support is mounted between upper and lower control arms. Wheel spindle pivots on steering knuckle spindle support. A strut bar is mounted between lower control arm and chassis. A torsion bar is mounted outboard to lower control arm by means of a torque arm and mounted inboard to chassis by means of an adjustable spring anchor. A hydraulic shock absorber is mounted between lower control arm and upper control arm mounting bracket. A stabilizer bar is optional and may be installed on some vehicles; it is mounted to front chassis members and connected at ends to lower control arms.

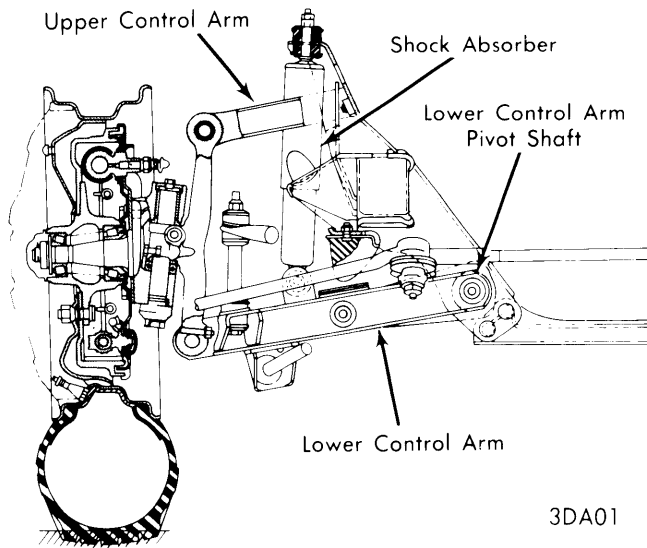

3DA01

DATSUN PICKUP FRONT SUSPENSION

ADJUSTMENT

WHEEL ALIGNMENT SPECIFICATIONS & PROCEDURES

See *Wheel Alignment Specifications & Procedures* in *WHEEL ALIGNMENT* Section.

WHEEL BEARING ADJUSTMENT

See *Wheel Bearing Adjustment* in *WHEEL ALIGNMENT* Section.

BALL JOINT CHECKING

See *Ball Joint Checking* in *WHEEL ALIGNMENT* Section.

REMOVAL & INSTALLATION

SHOCK ABSORBER

Removal — Remove nut and slide out bolt retaining shock absorber to lower control arm. Remove upper shock absorber retaining nut and remove shock absorber from vehicle.

Installation — To install, reverse removal procedure and tighten all nuts and bolts.

STABILIZER BAR

Removal — Remove bolts holding stabilizer bar brackets to frame. Disconnect link bolt attaching stabilizer bar to lower control arm. Remove stabilizer bar from vehicle.

Installation — To install, reverse removal procedure and note the following: Tighten nut on link bolt enough to reach a distance of 3.84" between top of lower control arm and center of stabilizer bar.

TORSION BAR

Removal — Raise and support vehicle and remove wheel and tire. Loosen nut securing spring anchor bolt. Remove dust cover at rear of torsion bar spring and remove snap ring. Remove anchor arm by pulling out rearward, then remove torsion bar.

Installation — To install, reverse removal procedure and note the following:

- 1) Coat serrated end of torsion bar with suitable grease and install it in torque arm. *NOTE* — Torsion bars are marked *left* and *right* on ends of bars. If both bars are removed at one time, make sure they are installed on their correct sides.
- 2) Install anchor arm and adjust to obtain dimension "A" as shown. After installing snap ring and dust cover, tighten adjusting nut until dimension "B" is obtained.

Application	Dimension "A"	Dimension "B"
Standard Body	.197-.591"	2.363-2.756"

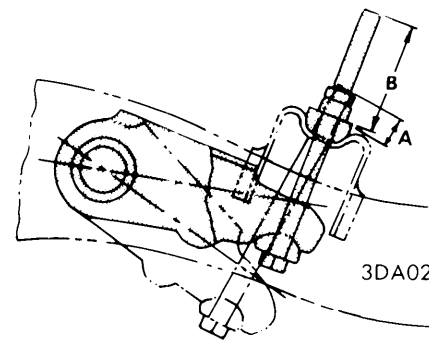

3DA02

INSTALLING ANCHOR ARM

STRUT BAR

Removal — Remove retaining bolts, washers and rubber grommets from both front and rear of strut bar. Remove front mounting bracket bolts and remove strut bar from vehicle.

Installation — To install, reverse removal procedure and tighten all nuts and bolts.

STEERING KNUCKLE SUPPORT & SPINDLE

Removal — Raise and support vehicle and remove wheel and tire. Remove brake drum and hub. Disconnect brake hose at wheel cylinder and remove backing plate. Remove king pin lock nut and plug from top and bottom of king pin. Drive out king pin with a drift punch and separate spindle from knuckle support. Remove shock absorber, stabilizer bar (if equipped), torsion bar and strut bar. Remove upper pivot arm nut and bolt, and separate knuckle support from upper control arm.

DATSUN 620 (Cont.)

Remove lower pivot shaft lock bolt and unscrew bushing from control arm. Drive out pivot pin and separate knuckle support from lower control arm.

Installation – 1) Apply grease to pivot shaft, bolt and bushings before installing knuckle support. Screw bushings in equally to center knuckle support in lower control arm. Install upper pivot bolt from rear side of vehicle. With knuckle support installed, inspect king pin for wear or damage. King pin and bushings in spindle are replaceable. Using a suitable bushing remover (ST35380000), remove bushings and grease seals. Thoroughly clean king pin bores and install new bushings as shown in illustration.

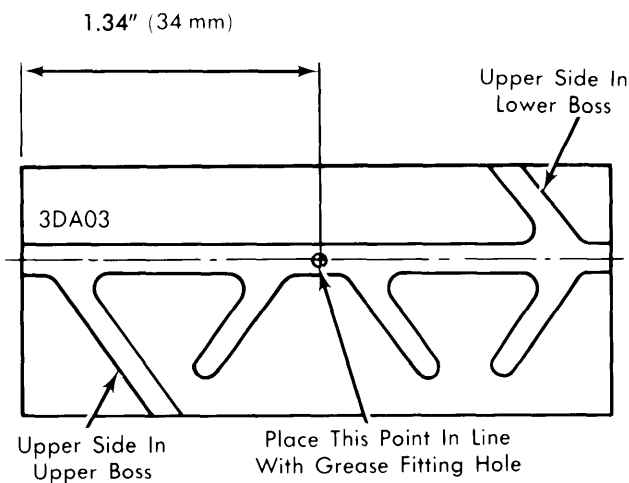

KING PIN BUSHING INSTALLATION

2) Remove grease fittings and drill holes through bushings. Ream inside of bushings to .7878-.7888". Press fit grease seal on upper end of spindle. Install spindle on steering knuckle support with thrust bearing covered side up. Install king pin but not lock bolt, place jack under spindle and raise slightly. Measure clearance between spindle and knuckle support. Standard clearance is .004" or less. Install and secure lock bolt. Install strut bar, torsion bar, stabilizer bar and shock absorber. Install remaining suspension components in reverse of removal procedure.

UPPER CONTROL ARM & BUSHINGS

Removal – Remove steering knuckle support from upper control arm. Remove bolts retaining upper control arm pivot shaft to chassis and remove upper control arm from vehicle. Separate both sides of control arm from pivot shaft by twisting off. Place separated sides of control arm in vise and remove bushings.

Installation – Install bushings in both sides of control arm and fill with grease. Install pivot shaft and tighten bushings until measurement between steering knuckle support end and control arm is 1.76". Install in vehicle and tighten bolts. Install steering knuckle support arm and check front suspension alignment.

LOWER CONTROL ARM & BUSHINGS

Removal – Remove steering knuckle support and drive out lower control arm pivot shaft. Remove bolts and separate torque arm from control arm. Using a suitable bushing remover (ST36070000), drive out lower control arm bushings from chassis mounts.

Installation – Using the same tool used for removal of bushing, drive in new bushing in lower control arm chassis mount. Install torque arm on lower control arm and place control arm in proper position on mount. Install pivot bolt and tighten nut. Install steering knuckle support and check front suspension and alignment.

TIGHTENING SPECIFICATIONS

Application	Ft. Lbs. (mkg)
Backing Plate-to-Spindle.....	30-36 (4.2-5.0)
Steering Arm-to-Spindle	75-88 (10.3-12.1)
King Pin Lock Bolt	15-18 (2.1-2.5)
Steering Knuckle Upper Pivot.....	28-38 (3.9-5.3)
Torque Arm (Arm End).....	20-27 (2.7-3.7)
Torque Arm (Serration Boss).....	13-19 (1.8-2.6)
Lower Control Arm Pivot.....	54-58 (7.4-8.0)
Upper Control Arm Bushing	253-398 (35-55)
Strut Rod Lock Nut.....	12-16 (1.6-2.2)
Strut Rod Bracket Bolts	12-16 (1.6-2.2)
Shock Absorber Upper Nut.....	12-16 (1.6-2.2)
Shock Absorber Lower Bolt.....	23-30 (3.1-4.1)
Stabilizer Bar Bracket Bolts.....	12-16 (1.6-2.2)
Anchor Bolt Lock Nut.....	20-30 (3.1-4.1)
Rubber Bumper Bolt.....	5-8 (.8-1.1)