

Wheel Alignment

SAAB SPECIFICATIONS & ADJUSTMENTS

TIRE INFLATION (COLD)

Before attempting to check or adjust wheel alignment, make sure tires are properly inflated. Refer to manufacturers specifications given in owner's manual.

CASTER

All Models – To adjust caster, add or remove shims under upper control arm bushing brackets. Changing shims from front to rear bracket increases caster angle. Moving shims from rear to front decreases caster angle. **NOTE** – Same thickness of shims removed from front must be placed under rear and vice versa. Change in caster also effects camber.

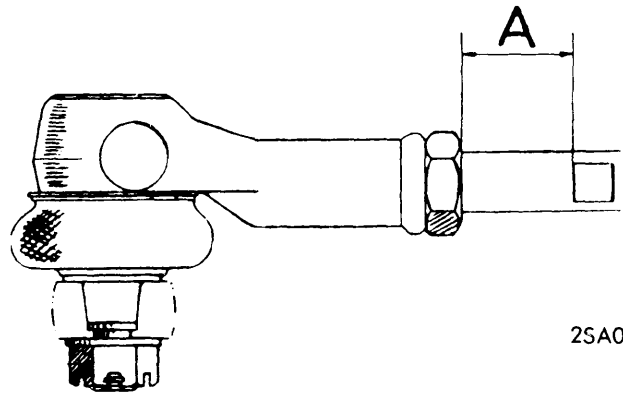

2SA01

CHECKING LENGTH OF TIE ROD WITH KEY GRIP

CAMBER

All Models – To adjust camber, add or remove shims under upper control arm bushing brackets. Increasing shims under both brackets reduces camber angle and removing shims under both increases camber. **NOTE** – Always add or remove same thickness of shims at front and rear or caster angle will be affected.

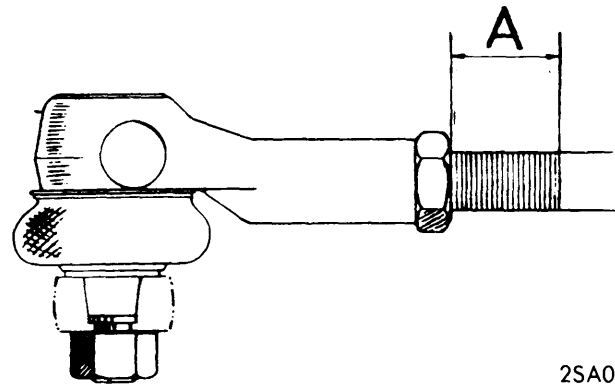

2SA02

TOE-IN

All Models – With wheels in straight-ahead position, loosen steering link (tie rod) lock nut and turn adjustable sleeve until correct toe-in is obtained. Tighten lock nuts and recheck toe-in.

NOTE – After adjustment of toe-in, measurement A (see illustration) of tie rod must not exceed 1.6" (with key grip) or 1.2" (without key grip). For tie rods opposite to each other the difference between the measurements A must not exceed .08".

CHECKING LENGTH OF TIE ROD WITHOUT KEY GRIP

WHEEL ALIGNMENT SPECIFICATIONS					
Application	Caster (Degrees)	Camber (Degrees)	Toe-In (Inches)	Toe-Out On Turns (Degrees)	
				Inner	Outer
Sonett 97	2 ± ½	0 ± ¼	0 to ⅝₆₄	21 to 24	20
Saab 99	1 ± ½	½ ± ½	-⅝₆₄ to ⅝₆₄	21 ½	20